

**TABLE OF CONTENTS:**

Introduction

Section 1.0 – Safety

Section 2.0 - Machine Setup

Section 3.0 – Machine Operation

Section 4.0 – Troubleshooting guide and notebook

Section 5.0 – Parts List



Figure 0.1 – ED-3339-2C in compression

**Introduction**

ABM International would like to thank you for the purchase of an ED3339-2C Compression Machine with Heat Sealing. ABM is confident that this machine will meet or exceed your expectations for cost, speed and durability.

If at anytime you experience problems with any of your ABM machines we ask that you contact us - 24 hours a day by calling our service department at (281) 443-4440. We can help you solve the problem quickly, and correctly. Your calls, questions, and comments will in turn help us to perfect the quality of our products and services in the future.

Once again, we thank you for your purchase.

ABM International, Inc.

Joe Podolski  
Vice President  
Engineering Department

## **Section 1: Safety**

### **1.0 Safety Introduction**

As with the operation of all machinery, safe operation of the ED3339-2C is a major concern of ABM International, Inc. The purpose of this section is to inform personnel of the safe and prudent operation of an ED3339-2C.

We have attempted to recommend the most effective methods and calculations to warn against actions that could result in personal injury, or make equipment unsafe. It is important to understand that ABM cannot anticipate, or list all conceivable safety methods and warn of all the possible hazards. In the interest of promoting safety, ABM advises that the operating personnel should always make sure that personal safety and the safe operation of the machine will not be adversely affected by their actions.

It is imperative that the operating personnel of the ED3339-2C read and understand the information in this manual before operating the machine.

### **1.1 Safety Policy Statement**

The conservation of the assets of any company, which include the buildings, equipment, supplies and inventories as well as personnel, must be and is the responsibility of all levels of management. The purpose of a personnel and property conservation program is to insure that all phases of management recognize that personnel and property conservation are both inseparable parts of a company's objective...to produce quality products at the lowest possible cost.

Safety of personnel in every aspect must be of first consideration. The implementation of a conservation program will eliminate human suffering and effectively lower the direct and indirect costs resulting from employee injury. It will substantially reduce the exposure and probability of damage and / or loss of company's physical assets.

### **1.2 Safety Practices**

The safety factors must be observed to ensure safe operation of the ED3339-2C.

1. Read and understand the operating instructions of the ED3339-2C before operating.
2. Use extreme caution when working around the ED3339-2C electrical controls.
3. Keep hands or other body parts away from the moving parts of the ED3339-2C.
4. Wear appropriate personal safety protection.
5. Stop the ED3339-2C immediately at any sign of malfunction or danger.
6. Do not crawl under or into the ED3339-2C for any reason during the operation of the machine.
7. Do not reach into the ED3339-2C at any time during the operation of the machine.
8. Do not climb, walk, or stand on the ED3339-2C at any time.
9. Do not tamper with factory installed guards and or safety devices.

**Safety Practices Continued:**

10. Never operate machinery without all ABM installed guards and safety devices intact, and in working order.
11. Before starting the ED3339-2C, ensure that no loose tools, bars or parts are lying in or on any part of the machine.
12. Proper fire fighting equipment should be kept in good operating condition and kept near in the event of fire.
13. Never attempt to service any of the pneumatic components until the unit is relieved of all air pressure.
14. Do not wear loose clothing or jewelry when operating the ED3339-2C.
15. Always keep hair from coming in contact with moving parts.

## **SECTION 2.0 – Machine Setup**

The ED3339-2C ships fully tested ready to operate. As a result, this manual provides a section on machine setup so that you can install the machine. Please read this manual in its entirety and follow all ABM instructions, especially the inspections. Total setup time, less power and air hook-up, should take approximately 1 hour.

### **SETUP INSTRUCTIONS:**

**INSPECTION #1:** Upon receipt of the machine, check to ensure that there is no visible damage. Figure 0.1 and the front cover of this manual are enough for this inspection.

**Note: that some components may be in different locations depending on the version of the machine.**

Determine the location in your facility for the compression machine. Attach the machine legs supplied with the machine to the plates that were used to bolt the machine to its skid. Level and position the machine in the desired location. Though not required, ABM recommends that the machine be bolted to the floor. Place the operator control station in front of the machine on the floor. Once a final position has been determined for the operator button station, coil any excess cable and wire tie it to the machine, which will reduce the risk of a tripping hazard.

Run a 220VAC line (25AMP) to the machine location. ABM does not recommend the use of any type of extension cord to power the machine. As with any machine, power should be run through approved conduit and ducting with proper termination. ABM does not supply a main power disconnect with the machine and recommends that the customer install one. You may have a licensed electrician connect the power to the machine at this time.

Plumb the machine with an air line capable of at least 100psi. ABM recommends that an air line of no less than .5 inches diameter be used for supply air. **NOTE: DO NOT CONNECT AIR TO MACHINE YET. UNTIL PROPER ELECTRICAL FUNCTION IS CONFIRMED. CONNECTING POWER AT THIS TIME CAN POSSIBLY RESULT IN INJURY.**

**INSPECTION #2:** Will confirm that the electronics of the compression machine are functioning properly.

**WARNING: ELECTRICAL SHOCK HAZARD. THIS INSPECTION WILL REQUIRE POWER TO BE ON WHILE THE ELECTRONICS CABINET IS OPEN. IF A PROBLEM IS FOUND, YOU SHOULD NOT ATTEMPT TO REPAIR IT WITH THE POWER ON. DISCONNECT THE MACHINE PRIOR TO ADJUSTING ANY COMPONENTS WITHIN THE ELECTRICAL CABINET.**

Step one; open the electronics cabinet located on the side of the frame of the machine. The internals of the cabinet will look like Figure 1.0. From left to right the components

are as follows: *Top row:* PLC, 24VDC Power Supply, (2) Relays, Resistor - *Middle Row:* Solid State Relays Input/Output terminals - *Bottom Row:* 210-110 Volt Transformer – *Vertical Column:* Disconnect, Power Distribution Block, Circuit Breaker, Capacitor. With the power turned on, the 24Vdc power supply should have a green LED marked DC ON illuminated. If the green light is not on, check the main power connection and check that the main disconnect is on.



Figure 2.0 – Electrical Panel.

Upon power up, the PLC screen should have a few flashing symbols and two rows of circles visible, this is the function screen of the PLC. If a different screen is visible, repeatedly press the ESC button on the PLC until this screen appears. If text is not visible on the PLC, check the incoming 24Vdc from the power supply. The PLC power terminals are marked with a + and – sign located on the top terminal strip.

When the PLC displays the function screen, the inputs and outputs can be tested. The PLC screen should now have a top row of six (6) circles with the letter I at the beginning (this is the input row). The lower row should have four (4) circles with the letter O at the beginning (this is the output row). A solid, dark circle means the input/output is on and a clear circle means the input/output is off.

**INPUT INSPECTION:** Depress and release the red E-stop button located on the operator station and main cabinet to ensure the PLC is reset to the beginning of the operation cycle. The second circle from the left on the input row (input #2) should be the only circle that is darkened. Depress and release the red E-stop button while watching the PLC screen. The second input should turn off and then back on when the button is released (this is the E-stop input). Depress and release the start button. Various inputs and outputs will illuminate, but only concern yourself with the input row at this moment. When the start button is depressed, the first circle (input #1) should darken. When the

start button is released, the input should shut off. Depress the red E-stop button to reset the machine. Press the stop button, the third circle should darken. Release the stop button and the third circle will shut off.

**OUTPUT INSPECTION:** Depress and release the red E-stop button located at the very top of the machines vertical beam to ensure the PLC is reset to the beginning of the operation cycle. At this time none of the four (4) circles in the lower row should be dark. Depress and release the start button once. The second circle of the lower row (output #2) should darken and a light on one of the air valves should illuminate. Wait a few moments, (output #3) will turn on, then (output #4) and finally (output #1). After a short time interval all outputs will turn off, the lights on all valves will turn off and the PLC will return back to its initial operation cycle. Only input #2, the E-stop should be on.

If both the inputs and outputs have checked out, the electronics cabinet should be securely closed.

#### **FINAL TEST:**

**WARNING – WHEN CONNECTING AIR TO THE MACHINE, YOU MUST ENSURE THAT THERE ARE NO LOOSE ITEMS SUCH AS TOOLS FOOD DRINKS ETC. ON THE MACHINE AND THAT ALL PESONNEL ARE CLEAR OF THE MACHINE.**

The machine is now ready for the air connection. When the air is turned on, the upper half of the mouth should move to its up position and the optional table should be fully extended (see figure 2.1). Adjust the pressure regulator so that a pressure reading of 80-90 psi is visible on the top gauge and 20-30 psi is visible on the lower gauge.



Figure 2.1 – ED3339-2A at start of cycle.

Inspect the front of the machine and ensure that the upper and lower mouth halves are clear from obstructions.

Step 1: Depress the start button once. The table will move in and the upper half of the mouth should compress and come to a stop.

Step 2: The heat sealer will extend and after a 3-5 second interval the mouth and table will simultaneously return to the up and extended positions.

Now check the proper function of the E-stop button.

Step 1: Depress and release the start button once. The table should retract.

Step 2: Now depress and release the E-stop button. All pressure should release from the machine.

Setup and inspection is now complete.



### **SECTION 3.0 – Machine Operation**

This section will discuss how to properly use the ED3339-2C to fulfill all of your bagging needs.

The ED3339-2C is equipped with an adjustable height UHMW platen (see figure 3.1). The upper mouth half compression stroke is adjustable. The stroke can be adjusted by turning the hand wheel on the left side of the machine.



Figure 3.0 – Operator Start Station.



Figure 3.1 – Upper platen stroke adjustment handle.



Figure 3.2 – E stop and Heater adjustment

**Basic Operation: (Operator instructions)**

- Step 1: Insert product into a bag and then onto the lower table of the staging area.
- Step 2: Make sure all body parts are clear of machine. Depress the operator start button.
- Step 3: The machine will move the staged product into the compression area and will fully compress the product.

Step 4: The machine will then automatically heat seal the bag and the table will return to the staging area.

Step 5: Remove the packed good; from the machine and repeat the process again.

### Temperature Controller Adjustment:



Figure 3.3 Temperature Controller

The temperature controller (Figure 3.3) is located on the top of the main cabinet adjacent to the E-stop button. All adjustments to the Heat Sealer are made from this display. The display can be cycled through its menu by pressing the mode button. There are five screens accessible by pressing the mode button; total number of cycles, heat seal temperature, heat seal time, cool down temperature, and heater bar current temperature. The steps below will guide you on how to adjust the various parameters.

#### Adjusting heat seal temperature:

Press the mode button until the display appears as above in figure 3.3. Press the offset buttons numbered one through five directly below the digit you wish to change. When finished, press and hold the set key until the number stops blinking. The controller keeps the heater bar at this temperature for the specified heat seal time.

#### Adjusting heat seal time:

The controller keeps the heater bar at its seal temperature for a period of time known as the heat seal time. Thick or wrinkled bags may require more seal time than thin bags. The controller allows for adjustment of the heat seal time. Press the mode key until the display shows a number with the (sec or s) label next to it. This is the heat seal time. Adjust the time by pressing the offset numbered keys below the digit you wish to change. Press and hold the set key until the number stops blinking.

**Adjusting cool down temperature:**

The cool down temperature allows the heater bar to stay in a compressed position until the heater bar and product being sealed has cooled sufficiently. The adjustment is made similarly to adjusting heat seal temperature.

NOTE: Cool down temperature can cause cycle times to increase drastically. If the machine is operated in a non-climate controlled facility it is recommended that a cooling system be added to the machine. Cooling systems will allow for consistent cycle times regardless of ambient or heat sealing temperatures.

**Viewing heater bar current temperature:**

Press the mode key until the current temperature can be seen.

**Viewing total number of cycles:**

Press the mode key until the number of cycles is displayed. This is the total number of cycles the heater bar has run.

## **SECTION 4.0 – Troubleshooting guide**

This section is included to help diagnose and solve any problems that may occur with the ED3339-2C. ABM has done its best to include as much information as possible.

However, not all problems are listed, therefore ABM asks that whenever a problem occurs you contact a service technician at our home office. To reach service dial 281-443-4440 and ask for a service technician, they are on call 24 hours a day, seven days a week.

### **Electrical power:**

The ED3339-2C runs on a 25 amp, 220VAC supply line. The PLC, inputs and outputs (valves) run on 24Vdc produced by the power supply found in the cabinet. The PLC has its' incoming power fused through a terminal block found inside the cabinet. A fuse with a 10A rating is standard.

### **Verifying inputs and outputs:**

Table 4.0 lists the inputs and outputs, their location on the PLC and their normal wired condition.

<b>Description</b>	<b>PLC location</b>	<b>Wired Condition</b>
Start	Input #1	Normally Open (N.O.)
E-stop	Input #2	Normally Closed (N.C.)
Stop	Input #3	Normally Open (N.O.)
Seal done	Input #4	Normally Open (N.O.)
Heat Sealer	Output #1	Normally Open (N.O.)
Table Valve	Output #2	Normally Open (N.O.)
Compression Valve	Output #3	Normally Open (N.O.)
Seal Cylinder Valve	Output #4	Normally Open (N.O.)

Table 4.0 – PLC inputs and outputs.

To verify that an input or output is functioning properly, the PLC displays a status screen of the I/O. To enter the status screen, depress the escape button until a screen with two rows of circles is displayed. The top row of six (6) circles, marked with a letter I, displays the inputs. A darkened in circle signifies the input is on; a clear signifies the input is off. Depressing either the foot pedal or E-stop will cause their corresponding input to turn on and off. Outputs function the same way, if a circle in the lower row is darkened in; the output is on.

**Pneumatic systems:**

The pneumatic system of an ABM ED3339-2C is very straightforward. The system consists of a valve block with four (4) valves, a cylinder for compression, (4) cylinders for heat sealing the product, one (1) cylinder for table shuttle, two (2) filter/regulator combo units and a blow off valve.

Valve block: a device used to distribute air to multiple valves from a common location. The valve block on the ED3339-2C has four (4) valves and a 25-pin connector for communication to the PLC.

Valve (individual): A valve is a device found on the valve block that is operated individually through the PLC. It is possible to manually cycle an individual valve by depressing the small orange button located directly on the valve. A small screwdriver or a pen may be needed to depress the button properly. Removal of a valve for service is accomplished by loosening the small socket head cap screw located directly above the valve, and gently pulling the valve out away from the manifold. Installation is made by reversing the above procedure.

Cylinders: Some cylinders are uneconomical to repair and thus any damage that may occur to a cylinder should be rectified by replacing the cylinder. Others have low cost repair kits available from ABM.

Quick exhaust valves (optional): These valve are mounted directly to the cylinder ports. They allow the cylinders to move more quickly by exhausting the air inside the cylinder faster than the main manifold can. The machine can operate normally with or without the valves installed.

Filter/regulator combo unit: The combo unit is the machines last line of defense against foreign materials (water, steel particles, etc.) found in pneumatic lines. The machine can be run without a combo unit but serious damage can occur to the valve block and cylinders. The combo unit also performs the task of regulating the incoming air pressure. Air pressure on both the compression and ejection cylinders is individually adjustable. Pressures should be set according to machine demand. Excessively high or low pressures may cause the machine to function improperly.

Blow Off Valve: Electrically piloted valve used to release all air pressure from the machines cylinders in the event the E- Stop is activated.

**Troubleshooting notes:**

A few blank pages are provided so that you and your personnel can keep records and notes of machine problems. By using this section and keeping it attached to the manual, you will always have your own personalized quick reference repair section.

TROUBLESHOOTING NOTES:

Date	Problem	Solution

TROUBLESHOOTING NOTES:

Date	Problem	Solution



## **SECTION 5.0 - PARTS LIST**

This section lists the ABM part numbers needed to order any part on the ED3339-2C. ABM carries all of the components below in stock at all times (unless noted with an \* next to the number in the quantity column). Non-stock items can usually be shipped within 2-3 days however some custom cylinders and mechanical components can take as long as 2-3 weeks to manufacture. Any order for stock parts placed before 5:00 P.M. C.S.T. can be shipped the same day for next or second day delivery. The parts/service department can be reached at (281) 443-4440. As with any machine, buying the correct parts from the correct manufacturer will allow your machines to operate at their best. Buying parts from sources other than ABM will void your warranty.

### **ABM International, Inc.**

#### **HEAT SEALER ORDER SHEET - PROJECT #3000**

**220 / 1 Phase 60Hz - 25A  
100 PSI**

<b><u>Qty</u></b>	<b><u>Item Description</u></b>	<b><u>ABM Part #</u></b>
-------------------	--------------------------------	--------------------------

#### **COMMERCIAL COMPONENTS**

4	Plastic top	C-3000-001
4	Plywood	C-3000-002
1	Handwheel	C-3000-003
10	1/4" Tube clamps	C-3000-004
10	3/8" Tube clamps	C-3000-005
4	Large Mount	C-3000-010
6	Small Mount	C-3000-011

#### **DRIVE TRAIN COMPONENTS**

1	Acme screw - 1"-5 36"	D-3000-001
2	Acme coupling nut	D-3000-002
4	1" Pillow Block	D-3000-400
3	5/8" Pillow Block	D-3000-401
2	5/8" 2-Hole Flange Bearing Block	D-3000-402
17	4" V-groove Roller Wheel	D-3000-410
1	Brass Sprial Gear	D-3000-600

1	Steel Worm Gear	D-3000-601
3	Sprocket 17 tooth	D-3000-610
1	Sprocket 16 Tooth (5/8" to 1" chain drive) (on 1" side)	D-3000-611
3	Bushing 1"	D-3000-612
1	Bushing 5/8"	D-3000-613
15	#40 Chain	D-3000-800
2	Clamptite Collar 5/8	D-3000-900

### **ELECTRICAL COMPONENTS**

1*	36x24x10 Enclosure, Nema 12, with panel	E-3000-001
1*	Heat controller	E-3000-002
1*	Transformer - 240V to 120V, 5kVA, 50% Duty	E-3000-003
1*	Capacitor	E-3000-003
1	PLC controller	E-3000-004
2	Solid State Relay	E-3000-005
1	Power Supply - 24Vdc	E-3000-006
2	Relay	E-3000-007
2	Relay base for above	E-3000-008
1	Relay - 24vdc coil DPDT	E-3000-009
1	Circuit Breaker - 25A	E-3000-010
1	Power Distribution Block	E-3000-011
2	Resistors - 10kOHM, 5W	E-3000-012
1*	Thermocouple w/ quick disconnect (YELLOW)	E-3000-013
1*	Thermocouple quick disconnect socket (YELLOW)	E-3000-014
1	Power Interlock	E-3000-015
1	6ga Splice kit	E-3000-016
1*	Sealing Head/Base	E-3000-100
1*	Pre-fab element	E-3000-101
1*	Teflon tape	E-3000-102
1	2 Button start/stop station	E-3000-400
1	Mechanical plunger switch	E-3000-500
1	Mini-Limit switch cable connector	E-3000-501
2	1 NC Mushroom head E-stop push button station	E-3000-600
70	Power Cable - 6ga. Single conductor	E-3000-800
1	25 Pin Serial Valve Cable 1M long	E-3000-800
20	16 ga 4-cond Hi-flex cable	E-3000-801
15	2 Cond. HI-FLEX CABLE	E-3000-802
6	1/2" Liquid-Tite Conduit fittings	E-3000-900
2	DIN Rail - 8" long	E-3000-902
1	Fuse holder	E-3000-903
10	Sensor terminal blocks	E-3000-904
10	Output terminal blocks	E-3000-905
3	Ground Block	E-3000-906
4	Terminal end block	E-3000-907
1	1/2 Amp Fuse	E-3000-908
1	Cable carrier for Shuttle - 32 links	E-3000-920
1	Cable carrier for Squasher - 20 links	E-3000-921

**PNEUMATIC COMPONENTS**

1	Pneumatic manifold only - 4 station	P-3000-001
3	Valve	P-3000-002
1	Block Plate	P-3000-003
1	Pressure block plate	P-3000-004
1	Blow off valve	P-3000-010
1*	Compression cylinder	P-3000-100
*	Compression cylinder repair kit	P-3000-101
4*	Heat Seal compression cylinder	P-3000-200
4	Heat Seal compression cylinder clevis	P-3000-201
1*	80" Stroke Cable Cylinders	P-3000-300
*	80" Cable Cylinder Repair Kit	P-3000-301
2	Regulator/Filter Combo Unit	P-3000-800
	Regulator bracket	P-3000-800-01
	Regulator gauge	P-3000-800-02
2	1/4" Tube x 1/8 NPT Straigt	P-3000-900
5	1/4" Tube x 1/8 NPT Elbow	P-3000-901
4	1/4" Tube x 1/8 NPT Branch Tee	P-3000-902
2	1/4" Tee	P-3000-903
2	1/4" Tube Plug	P-3000-904
2	3/8" Tube x 1/4 NPT Straight	P-3000-905
2	1/4" Tube In-line Flo control	P-3000-906
1	1/4" Tube x 3/8 NPT Elbow	P-3000-907
16	1/4 blue hose	P-3000-910
16	1/4 yellow hose	P-3000-911
16	1/4 orange hose	P-3000-912
3	3/8 yellow hose	P-3000-913

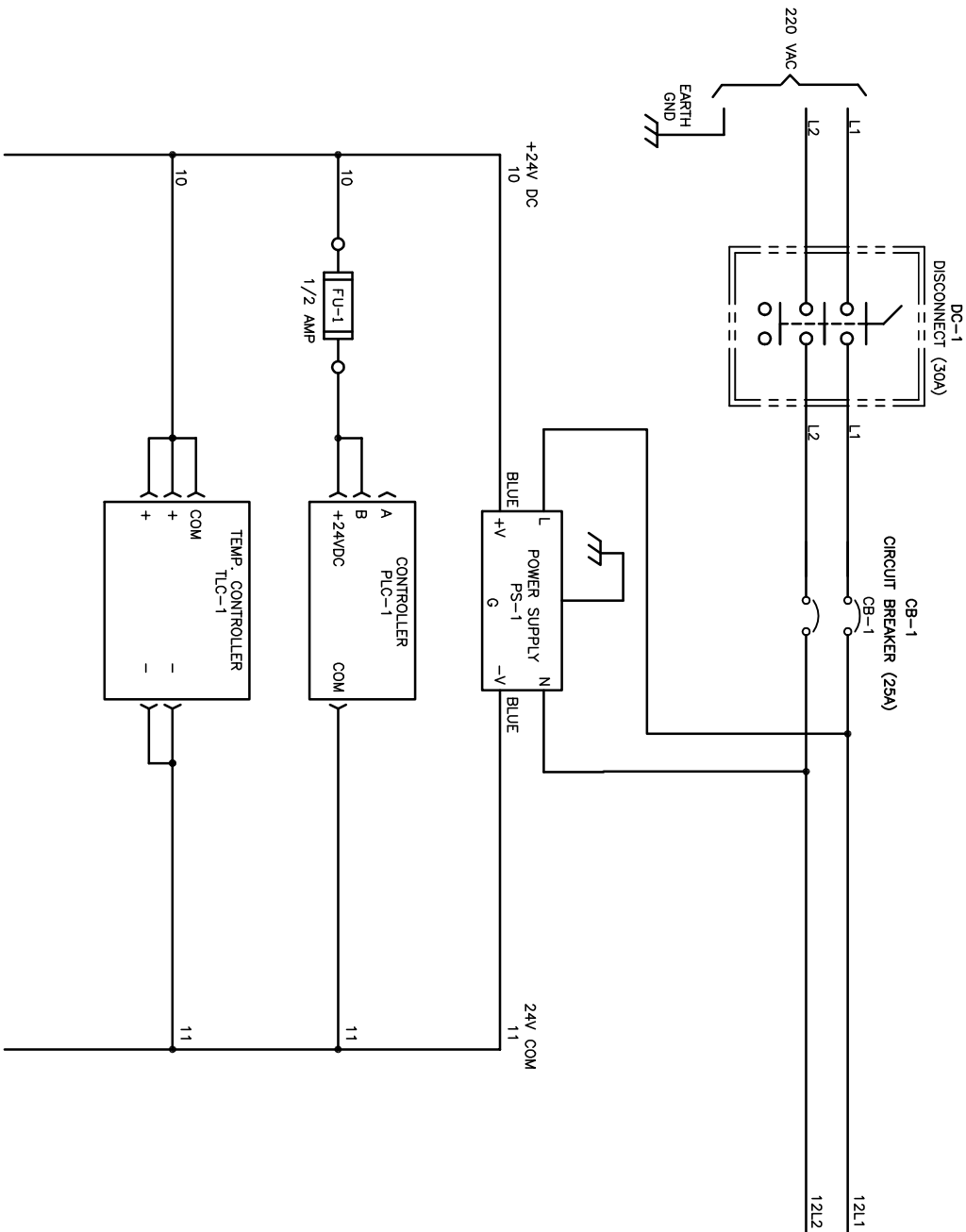

<b>INCHES</b>		<b>ABM</b>	
UNLESS OTHERWISE SPECIFIED		INTERNATIONAL	
DO NOT SCALE DRAWING		211 SEZERS AVE.	
ALL DIMENSIONS ARE IN INCHES		EVA CROOK VALDIE, IL 60007	
ALL DIMENSIONS ARE TO FACE UNLESS OTHERWISE SPECIFIED		SCHEMATIC WIRING POWER	
ALL DIMENSIONS ARE TO FACE UNLESS OTHERWISE SPECIFIED		PILLOW ROLLER	
ALL DIMENSIONS ARE TO FACE UNLESS OTHERWISE SPECIFIED		DRAWN BY: JOE FODOLSKI	
ALL DIMENSIONS ARE TO FACE UNLESS OTHERWISE SPECIFIED		DATE: 8/28/05	
ALL DIMENSIONS ARE TO FACE UNLESS OTHERWISE SPECIFIED		CHECKED BY: -	
ALL DIMENSIONS ARE TO FACE UNLESS OTHERWISE SPECIFIED		TOTAL SHEETS: 1	
ALL DIMENSIONS ARE TO FACE UNLESS OTHERWISE SPECIFIED		SHEET NO.: 1	
ALL DIMENSIONS ARE TO FACE UNLESS OTHERWISE SPECIFIED		SCALE: FULL	
ALL DIMENSIONS ARE TO FACE UNLESS OTHERWISE SPECIFIED		DRAWING NO.: E-3000-101	

B SIZE



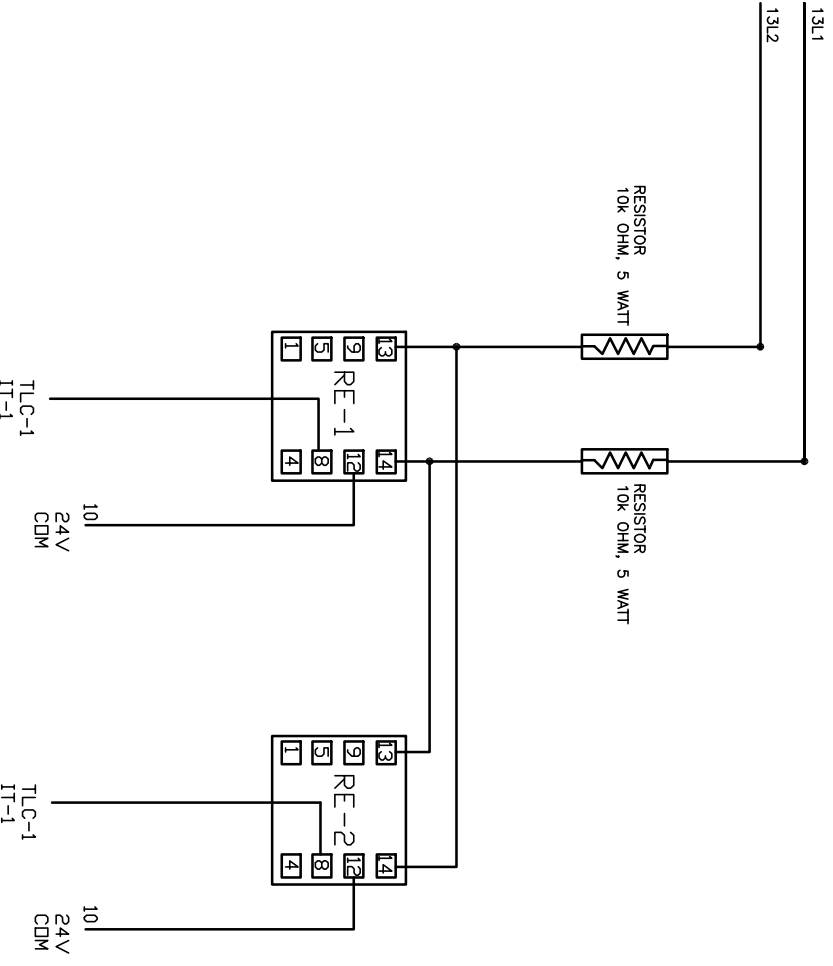

**INCHES**  
UNLESS OTHERWISE SPECIFIED

**ABM**  
INTERNATIONAL  
214 SEIZERS AVE.  
ELK GROVE VILLAGE, IL 60007

DATE: 8/28/05  
SCALE: FULL

DESIGNED BY: JOE FODOLSKI  
DRAWN BY: [blank]  
CHECKED BY: [blank]  
SHEET NO.: 1

NO. OF SHEETS: 1

TITLE: SCHEMATIC WIRING POWER PILLOW ROLLER

PROJECT NO.: E-3000-103

DATE: [blank]

SCALE: FULL

DATE: [blank]

NO. OF SHEETS: 1

TOTAL SHEETS: 1

PROJECT NO.: E-3000-103

B SIZE

# INPUTS

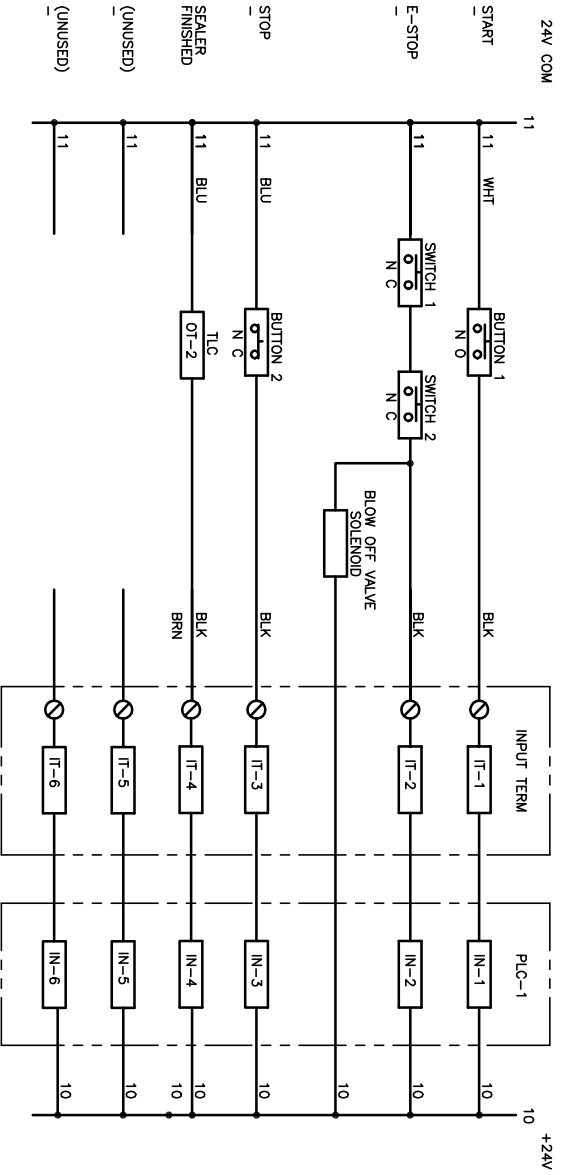

**INCHES**  
UNLESS OTHERWISE SPECIFIED

**ABM**  
INTERNATIONAL  
211 SEASONS AVE.  
EVA GROVE VALLEY, TX 48007

THIS SCHEMATIC, INPUTS, OUTPUTS  
PILLOW ROLLER

DESIGNED BY: JOE FODOLSKI  
DRAWN BY: [ ]  
CHECKED BY: [ ]  
DATE: 6/28/05

TOTAL NO. SHEETS: 1  
TOTAL SHEETS: 1  
SCALE: FULL  
DRAWING NO.: E-3000-104

B SIZE







# OUTPUTS

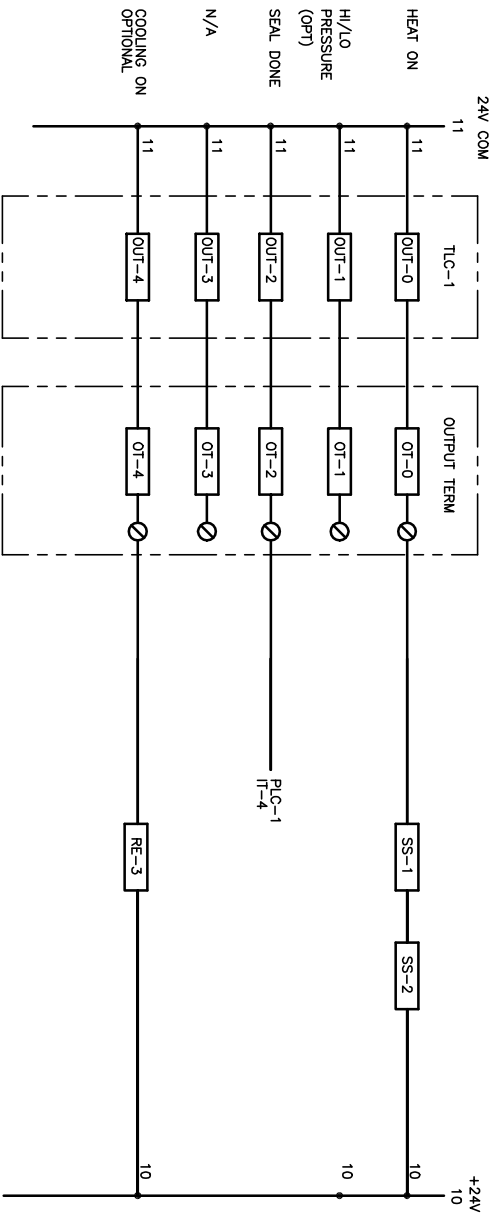

**INCHES**  
UNLESS OTHERWISE SPECIFIED

**ABM**  
INTERNATIONAL  
211 SEASIDE AVE.  
ELK GROVE VILLAGE, IL 60007

DATE: 8/28/05  
JOB: E-3000-107

DESIGNED BY: JOE PODOLSKI  
DRAWN BY: [blank]  
CHECKED BY: [blank]  
SCALE: FULL  
SHEET NO.: 1 OF 1  
TOTAL SHEETS: 1

PROJECT: SCHEMATIC, INPUTS, OUTPUTS  
TITLE: PLOW ROLLER

B SIZE