

18" Pro-frame Parts List -

Structural frame profiles –

Perforated square tube:



- (Qty. 1) Frame size in inches (i.e. 6' frame = 72", except 12' = 141")
- (Qty. 2) 36"
- (Qty. 2) 34.5"
- (Qty. 2) 33"
- (Qty. 2) 22.5"
- (Qty. 3) 21"
- (Qty. 1) 18"
- (Qty. 2) 15"
- (Qty. 6) 13.5"

Perforated rail tube:



- (Qty. 2) Frame size in inches minus 3" (i.e. 6' frame = 69", except 12' = 138")
- (Qty. 2) 30.0"

Slotted beam:



- (Qty. 2) 4.5"
- (Qty. 2) 6"
- (Qty. 2) 9"
- (Qty. 2) 15"
- (Qty. 2) 20.5"

Round spacer beam:

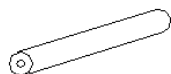

- (Qty. 2) 20.875"

Commercial Parts -

Lower carriage rear wheel assembly (Qty. 1)

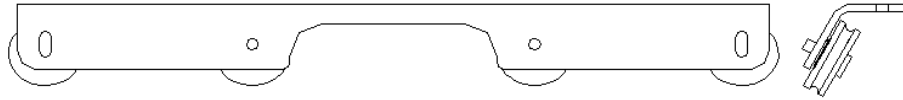

Lower carriage front wheel assembly (Qty. 1)

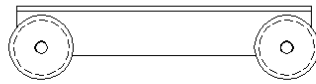

Liner roller collar adjustable angle bracket (Qty. 1)

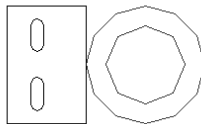

Liner roller collar adjustable angle bracket with hand wheel (Qty. 1)

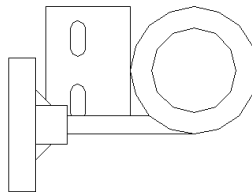

Take-up / bed roller collar (Qty. 3)

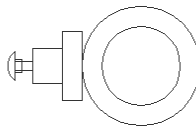

Take-up roller collar with hand wheel (Qty. 1)

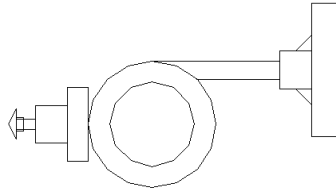

Top fabric roller collar mount (Qty. 1)

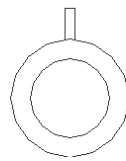

Top fabric roller collar mount with hand wheel (Qty. 1)

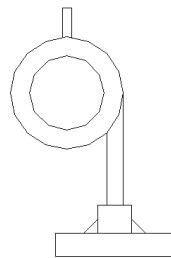

Steel strap (Qty. 6)



Side clamp (Qty. 2)

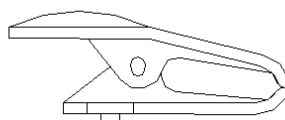

Pointer (Qty. 1)



Pivot arm bracket (Qty. 4)

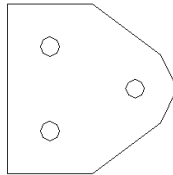

Roller tube (Qty. 4) – Frame size plus 2 inches (i.e. 6' = 74")



Roller collar (Qty. 8)



Gas spring with ball mounts (Qty. 2)

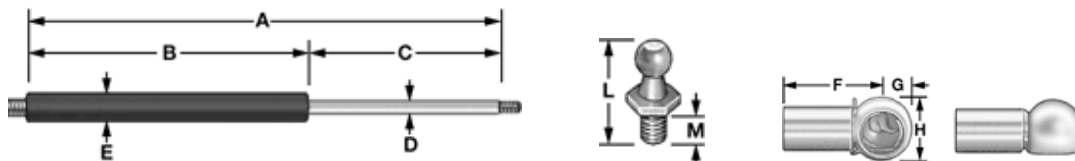

Pivot arm shoulder bolt and plastic washer (Qty 4)



Rubber bumper (Qty. 2)



Rubber tape roll (Qty. 1 roll)



Roll end cap (Qty. 8)



Rubber screw cap (Qty. 2)



Adjustable elastic cord clip (Qty. 2)



Elastic cord (Qty. 2)



Table tops (Qty. dependant on machine size)

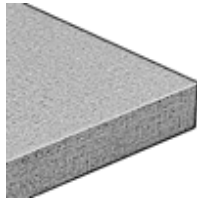

5 hole gusset plate (Qty. 6)



4 hole gusset plate (Qty. 4)

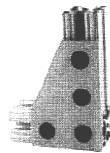

Pivot nub (Qty. 2)



Standard cross block (Qty. 16)



Extended cross block (Qty. 6)



5/16 T-nut (Qty. 20) *pictured with bolt installed*



#10 T-nut (Qty. 2) *picture with bolt installed*



Machine foot (Qty. 6)



Tubing end cap (Qty. 18)



Beam end cover (Qty. 4)



1/8" Thick steel shim (Qty 2)



Commercial Parts -

Bolt kit –

Hex head cap screw:



(Qty. 6) 5/16 x 1/2"
(Qty. 30) 5/16 x 3/4"
(Qty. 2) 5/16 x 1"
(Qty. 40) 5/16 x 2"
(Qty. 66) 5/16 x 2-1/4"
(Qty. 4) 5/16 x 2-1/2"
(Qty. 26) 5/16 x 3-1/2"

Socket head cap screws:



(Qty. 2) #10 x 3/4"

Flat washers:



(Qty. 200) 5/16

Lock washers:



(Qty. 30) 5/16

Nylon insert lock nuts:



(Qty. 100) 5/16

Hex nuts:



(Qty. 20) 5/16

18" Pro-frame machine leg assembly –

NOTE: MAKE (6) PIECES

Step 1: Install hex nut onto each of the (6) machine feet. Screw nut all the way down to the top of the flat on threaded foot.

Step 2: Install (1) flat washer onto each of the (6) machine feet.

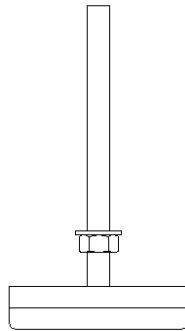

Step 3: Install machine feet into (6) extended cross blocks. Note only one end of cross block is threaded.

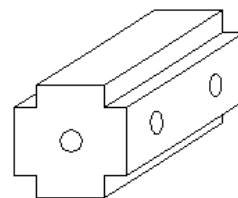
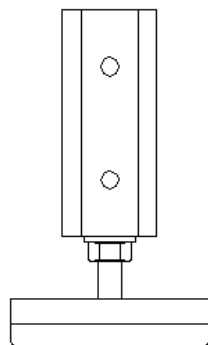

EXTENDED
CROSS BLOCK

Step 4: Install foot assembly into (6) 13.5" long tubes. Use (1) 2-1/4" hex bolt, (2) flat washers (one per side), and (1) nylon lock nut per assembly

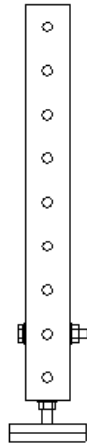

Step 5: Install (1) 1/2" hex bolt with (1) flat washer into the side of each leg assembly.

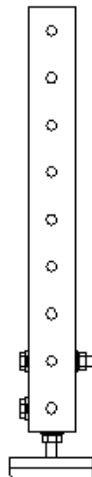

Step 6: Install (1) Plastic tube end cover into the open end of each foot assembly.

Step 7: Tighten all bolts, set aside.

18" Pro-Frame side rail support assembly –

IMPORTANT NOTE: Take care not to over-tighten nuts and bolts while assembling the aluminum Pro-frame. Unnecessary over-tightening will cause the frame pieces to twist and distort.

NOTE: MAKE ONE LEFT AND ONE RIGHT HAND ASSEMBLY.

Step 1: Install a standard cross block (2 total) into each end of the 33" tube using (1) 2-1/4 hex bolt, (2) flat washer (one per side) and (1) nylon lock nut. **NOTE: INSTALL THE BOLTS SO THE HEX HEADS ARE FACING THE SAME DIRECTION.**



Step 2: Install a standard cross block into one end of the 21" tube using (1) 2-1/4 hex bolt, (2) flat washer (one per side) and (1) nylon lock nut.

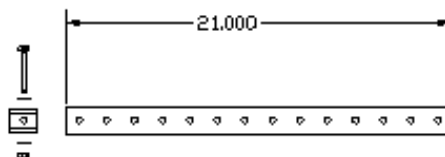

Step 3: Bolt 21" tube onto 36" tube through 2nd hole from one end. Use (1) 2" hex bolt and (1) flat washer. **NOTE: FOR A BETTER APPEARANCE, KEEP BOLT HEADS ON SAME SIDE.**

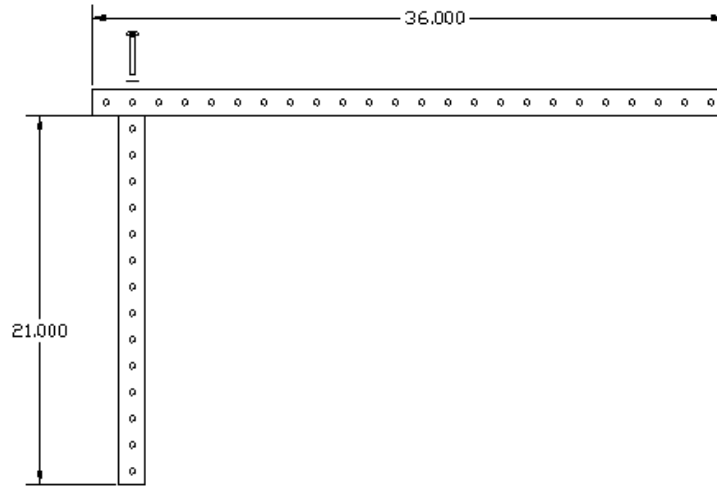

Step 4: Bolt 33" tube, from step 1, to 21" tube (9) holes down from connection to 36" tube. Use (1) 2" hex bolt and (1) flat washer.

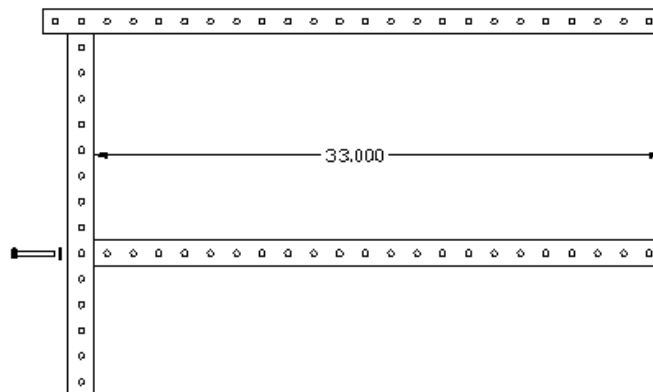

Step 5: Install 34.5" tube onto open end of 33" tube. Install into 6th hole from one end of 34.5" tube. Use (1) 2" hex bolt and (1) flat washer.

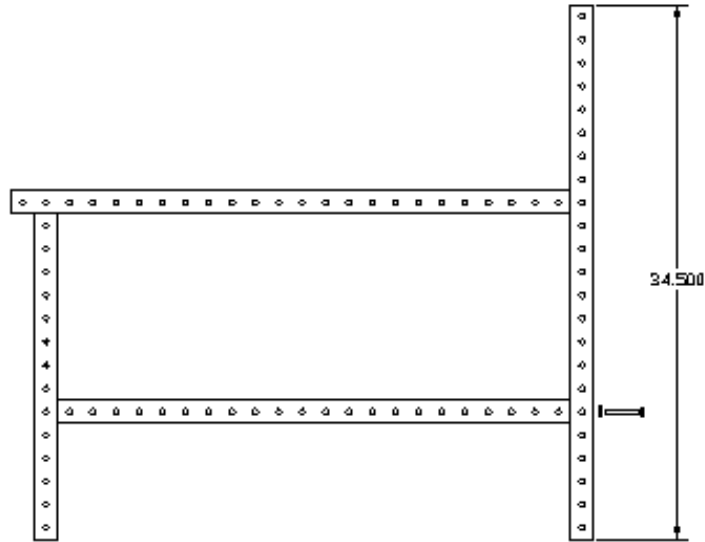

Step 6: Using (1) 5 hole gusset plate attach 36" tube to 34.5" tube. Use (5) 2-1/4" hex bolts, (10) flat washers (one per side) and (5) nylon lock nuts. **NOTE: MAKE SURE TO ASSEMBLE (1) LEFT AND (1) RIGHT ASSEMBLY.**

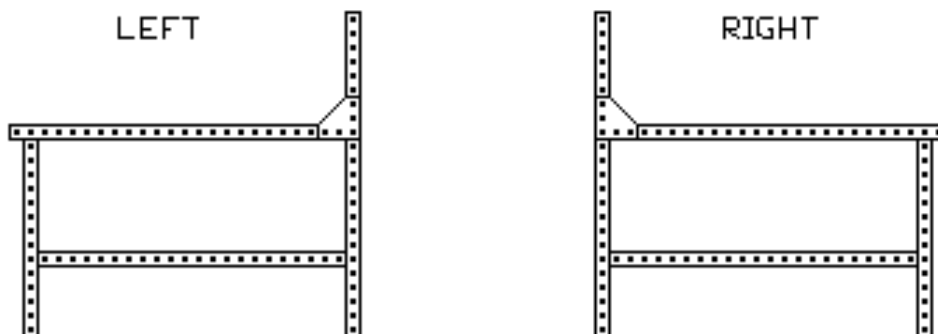

Step 7: Using (1) 5 hole gusset plate attach 20.5" slotted beam to 36" tube. Beam should mount through 9th hole from open end of 36" tube. Use (3) 2-1/4" hex bolts, (6) flat washers (one per side) and (3) nylon lock nuts to attach gusset plate to perforate square tubing. Place (2) 3/4" hex bolts with (2) lock washers (one on each bolt) in the open holes of the gusset plate. On the opposite side, attach (2) 5/16 T-nuts with the bump facing away from the gusset plate. Slide the 20.5" slotted beam onto the T-nuts and tighten.

NOTE: MAKE SURE TO ASSEMBLE (1) LEFT AND (1) RIGHT ASSEMBLY

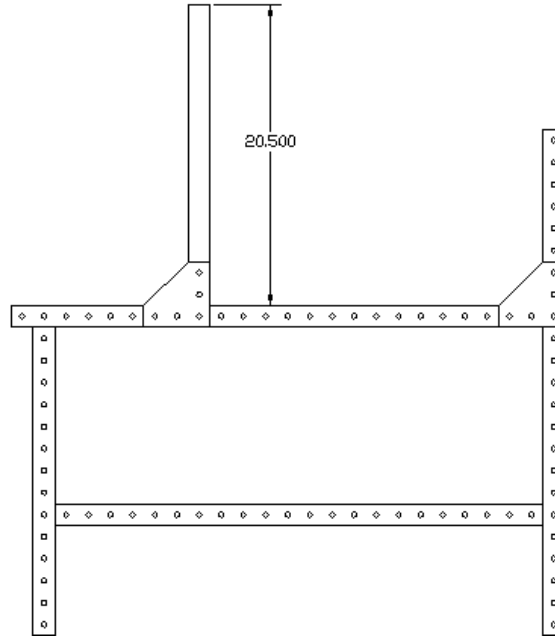

Step 8: Using (1) 5 hole gusset plate attach 15" perforated tube to 36" tube. 15" Tube should mount so that there are 4 open holes between the 5 hole gusset plates as in the picture below. Use (4) 2-1/4" hex bolts, (8) flat washers (one per side) and (4) nylon lock nuts. **NOTE: MAKE SURE TO ASSEMBLE (1) LEFT AND (1) RIGHT ASSEMBLY**

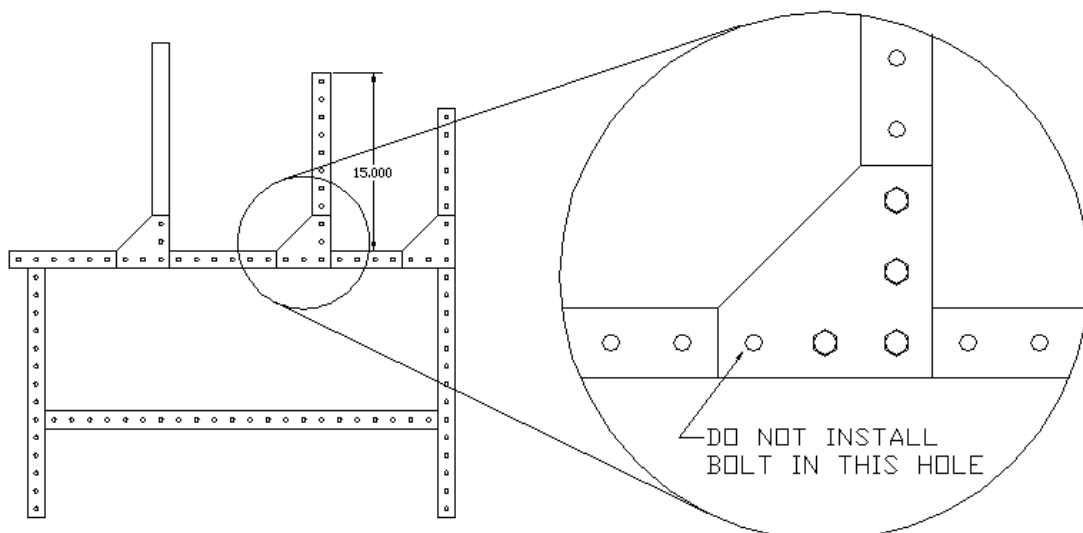

Step 9: Slide 5/16 T-nut into any side slot of the 9" slotted beam. Install (1) 9" slotted beam between 15" tube and 34.5" tube through the 6th hole from open end of 15" tube. Use (2) 2" hex bolt and (2) flat washers. Position the 9" beam so that the slot with the T-nut faces the same direction as the 5 hole gussets.

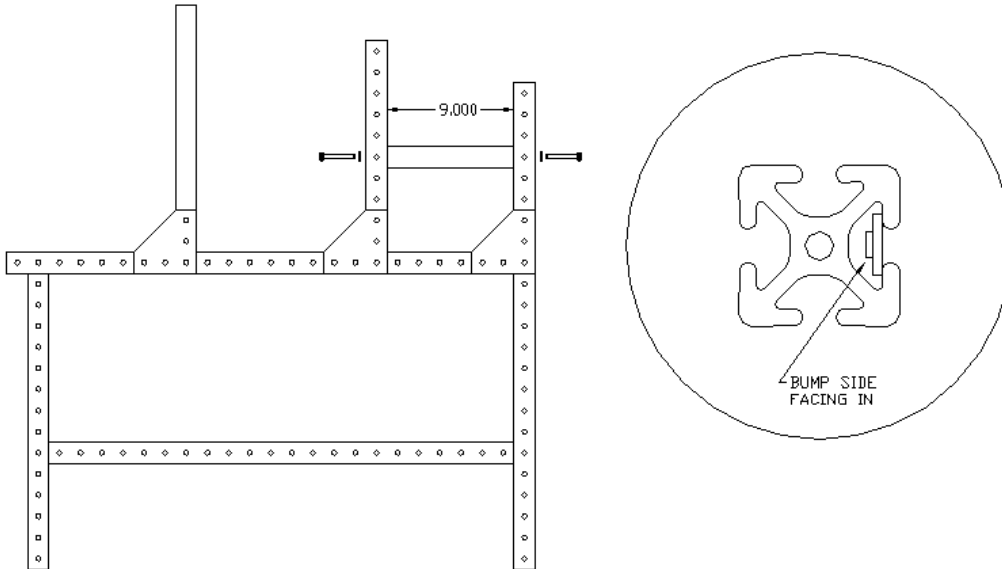

Step 10: Install liner roller support brackets to top end of 34.5" tube (also install a cross block into the end of the tube). Use (2) 2-1/4" hex bolt, (4) flat washers, (2) nylon lock nuts. The balloon on the left illustrates how to install the cross block into the tube end. The balloons on the right show a top view of the 34.5" tube with the liner roller support bracket installed correctly. **NOTE: THE LINER ROLLER SUPPORT BRACKETS ARE ORIENTED DIFFERENTLY DEPENDING ON WHETHER THE COLLAR HAS A HANDWHEEL OR NOT. THE HANDWHEEL SHOULD BE POSITIONED ON THE OUTSIDE OF THE FRAME, HOWEVER USERS MAY MOUNT IT TO THE INSIDE IF NECESSARY.**

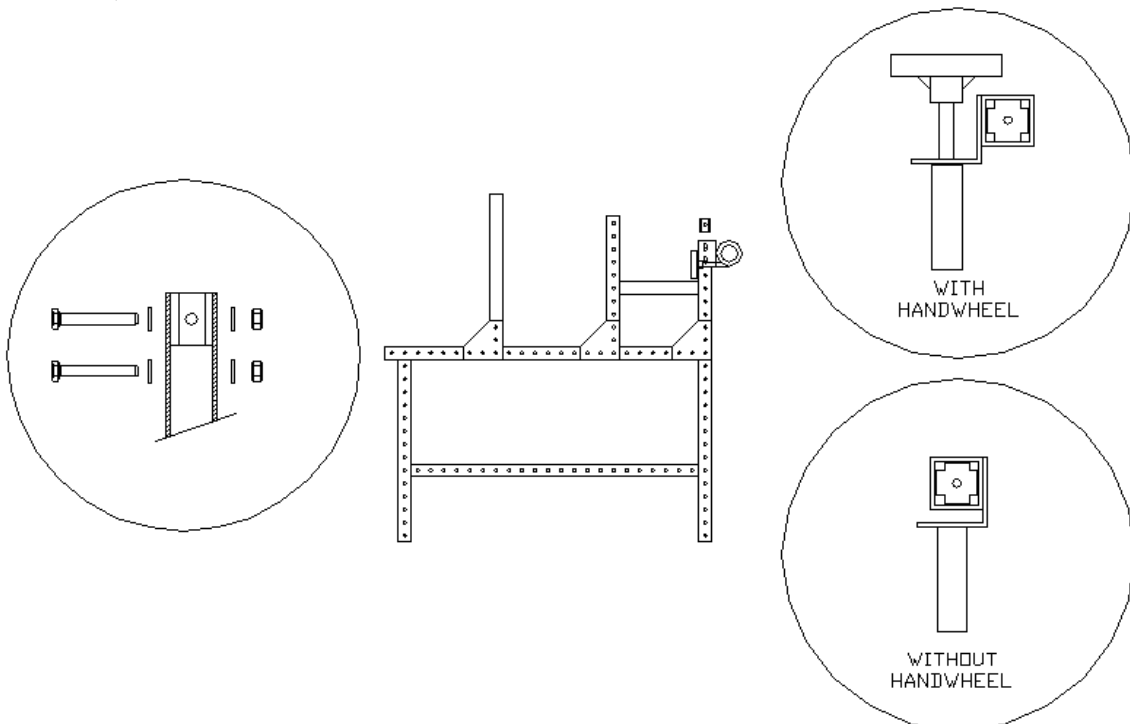

Step 11: Install (1) 1" hex bolt, (1) hex nut, and (1) flat washer into the end of the cross block. Install rubber cap onto head of hex bolt.

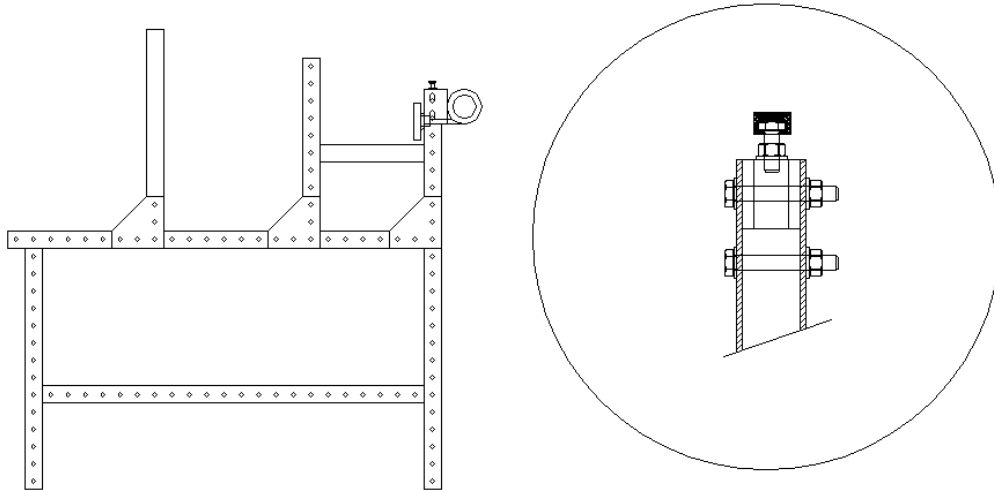

Step 12: Completed pro-frame left and right side rail support assemblies.

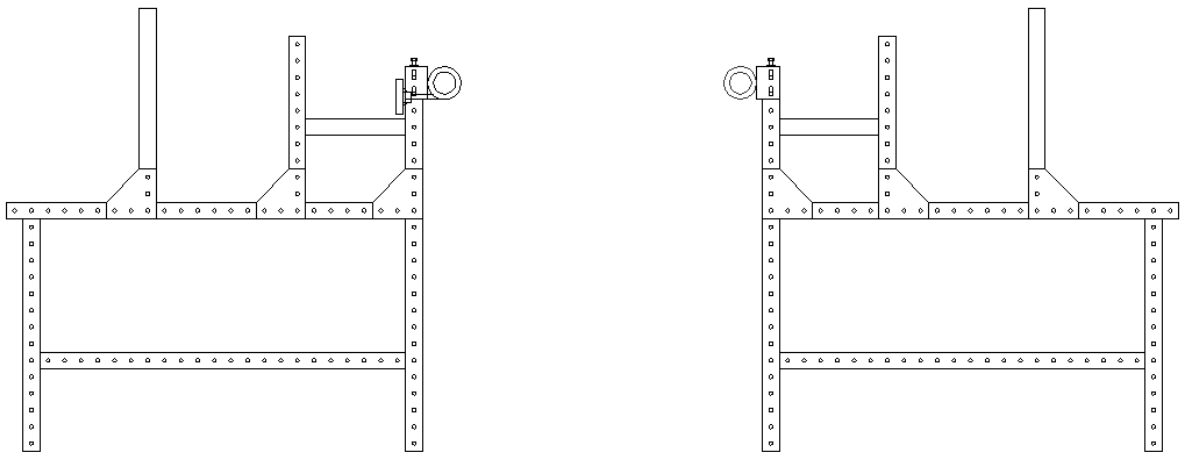

18" Pro-frame pivot roller assembly –

NOTE: MAKE ONE LEFT AND ONE RIGHT HAND ASSEMBLY

Step 1: Install pivot nub onto the threaded end of 15" slotted beam – only one end of the beam is threaded. Use bolt with supplied nub. **NOTE: REMOVE THE T-NUT AND SAVE.**

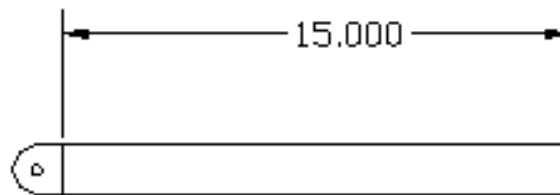

Step 2: Install 4-hole gusset plate onto 15" slotted beam approximately 1" from end with nub. Use (2) 3/4" hex bolts, (2) lock washers, and (2) T-nuts. **NOTE: MAKE SURE TO ASSEMBLE (1) LEFT AND (1) RIGHT ASSEMBLY**

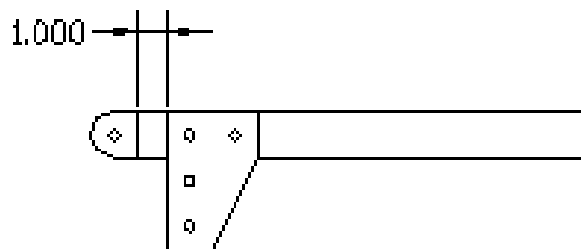

Step 3: Install 4 hole gusset plate onto open end of 15" slotted beam - flush to end. Use (2) 3/4" hex bolts, (2) lock washer, and (2) T-nuts

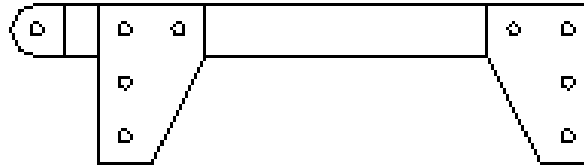

Step 4: Install top fabric roller support onto thread end of 4.5" slotted beam. Use (1) flat washer.

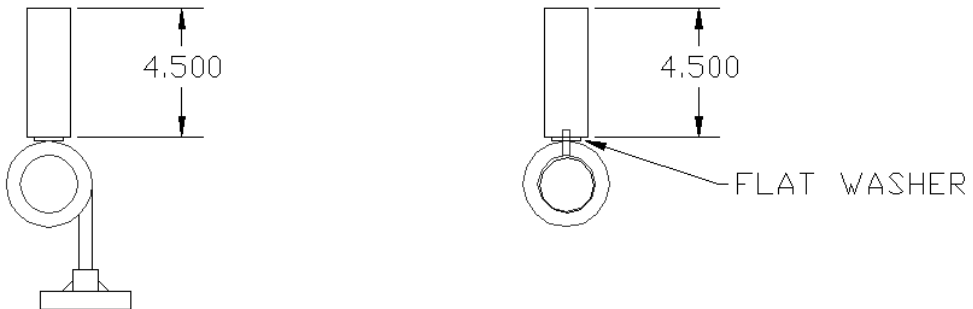

Step 5: Install 4.5" slotted beam onto 4 hole gusset mounted flush to end of 15" slotted beam. Use (2) 3/4" hex bolts, (2) lock washers, and (2) T-nuts.

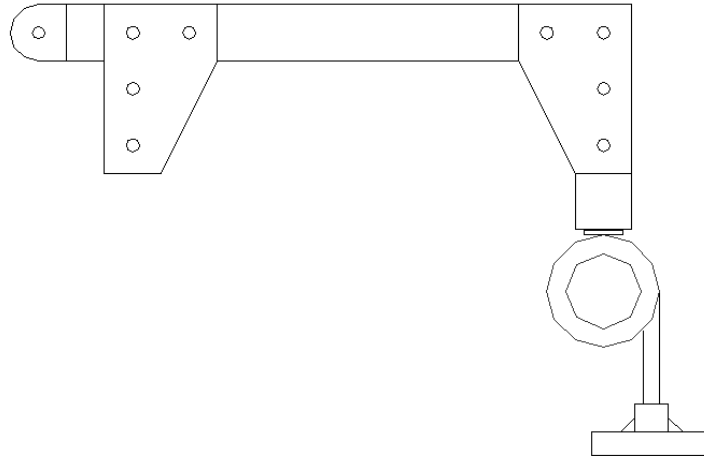

Step 6: Install (2) 3 hole pivot brackets onto nub end. Use (2) 3/8" shoulder bolts and (2) plastic washers. Install plastic washer between 3 hole plate and pivot nub.

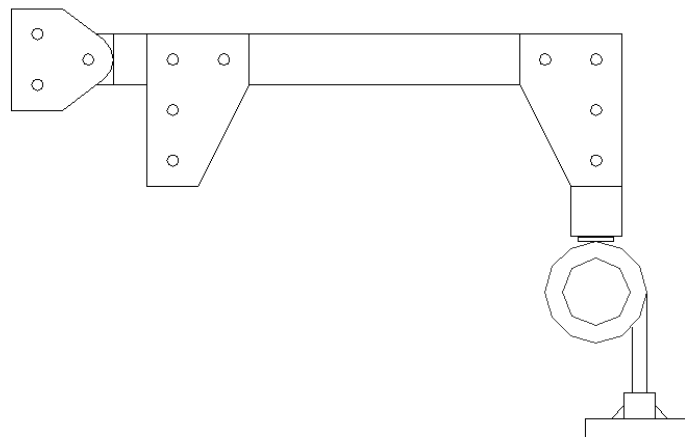

Step 7: Install pivot roller assembly onto 15" perforated tube located on side frame assembly. Use (2) 2-1/2" hex bolts, (4) flat washers, and (2) nylon lock nuts. Adjust the height of the rubber capped hex bolt so the 15" beam is level to the ground.

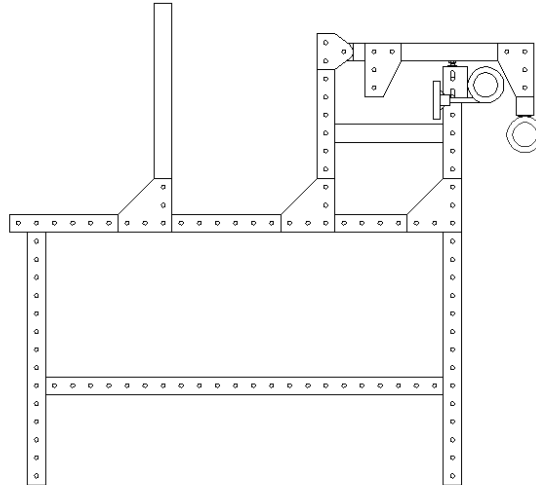

Step 8: Attach gas spring upper ball joint to 4 hole gusset plate and secure with (1) nylon lock nut. Install lower gas spring ball joint into t-nut located in 9" beam. Use (1) flat washer between lower ball joint and 9" beam. Tighten lower mount. NOTE: The gas springs can either install on the outside or the inside of the frame as pictured below. Extra hand clearance is achieved by installing the gas spring on the inside of the frame where collars are equipped with hand wheels.

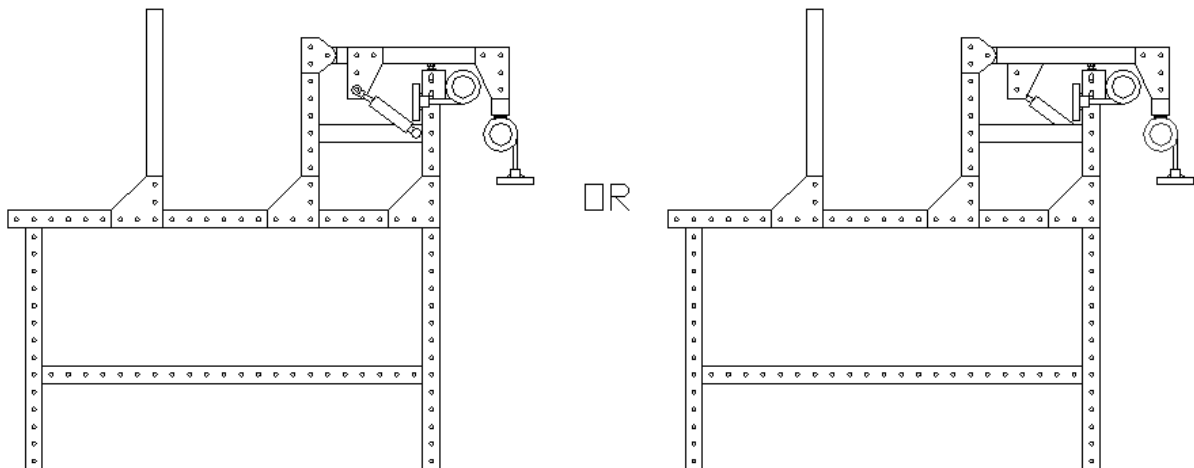

18" Pro-frame lower carriage assembly -

Step 1: Install a 6" slotted beam onto the (2) 30" P-rail tubes thru 2nd hole from open end. Use (2) 2" hex bolts, (2) flat washers. **NOTE: IF MACHINE IS EQUIPPED WITH STITCH REGULATION, INSTALL (1) T-NUT, INCLUDED WITH ENCODER WHEEL BRACKETS, IN THE OUTSIDE CHANNEL OF THE 6" BEAM.**

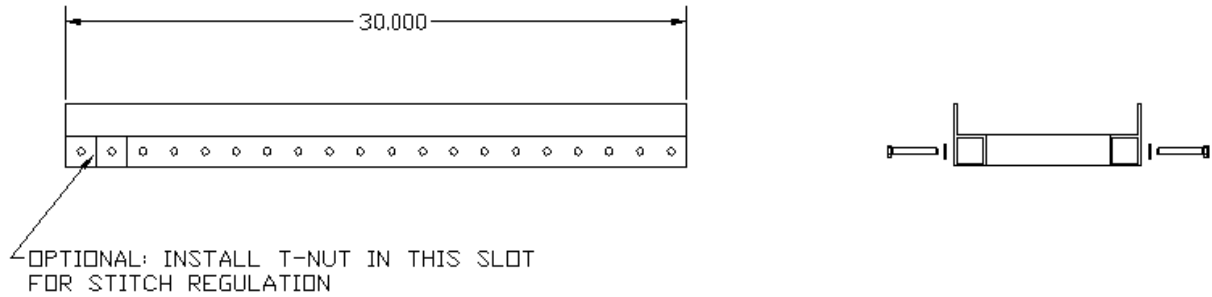

Step 2: Install a second 6" beam onto 30" tube. Mount thru 1st hole on opposite end of tube. Use (2) 2" hex bolts and (2) flat washers

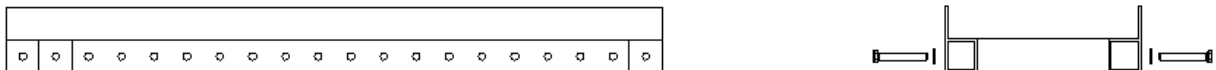

Step 3: Install rear carrier wheel mount onto 30" tube thru the 3rd hole from end of tube. Use (2) 2-1/4" hex bolts, (4) flat washers and (2) nylon lock nuts. **NOTE: SEE DRAWINGS FOR PROPER BRACKET AND WHEEL ORIENTATION. MAKE SURE TO CHECK FOR SQUARENESS WHEN TIGHTENING THE WHEEL BRACKET TO THE RAILS – USE A COMBINATION OR CARPENTERS' SQUARE IF AVAILABLE.**

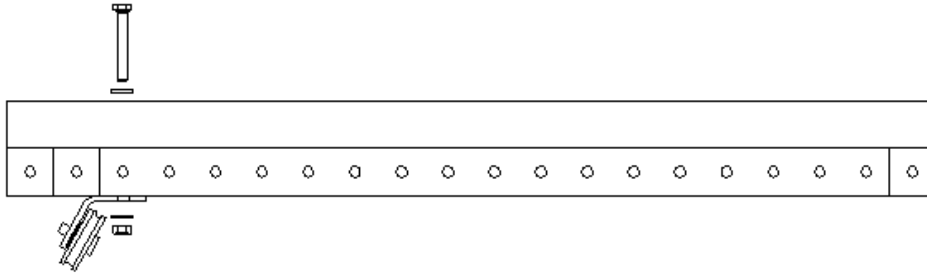

Step 4: Install front carrier wheel mount onto 30" tube thru the 4th hole from end of tube. Use (2) 2-1/4" hex bolts, (4) flat washers and (2) nylon lock nuts. **NOTE: SEE DRAWING FOR PROPER BRACKET AND WHEEL ORIENTATION.**

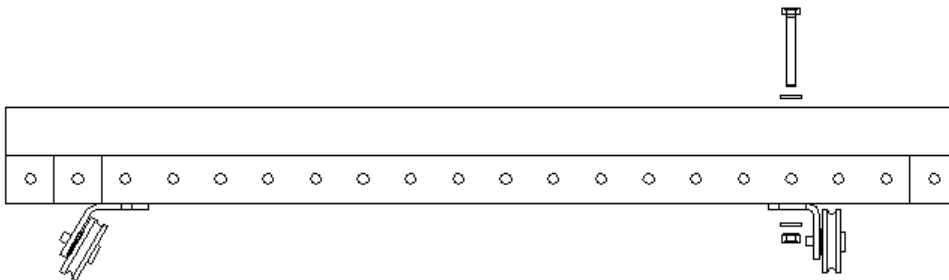

18" Pro-frame final assembly –

Step 1: Install (1) standard cross block (2 total) into each end of the long rail tubes using (1) 2-1/4 hex bolt, (2) Flat washer (one per side) and (1) Nylon lock nut. **NOTE: INSTALL BOLTS SO HEX HEADS ARE FACING THE SAME DIRECTION.**

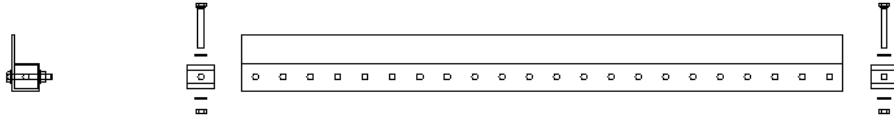

Step 2: Bolt long rail tubes to side support frame assemblies using (2) 2-1/4" hex bolts and (2) flat washers to bolt the front rail through the 5 hole gusset plate and use (2) 2" hex bolts, and (2) flat washers for the other rail. **NOTE: SEE DRAWING FOR RAIL ORIENTATION AND LOCATION.**

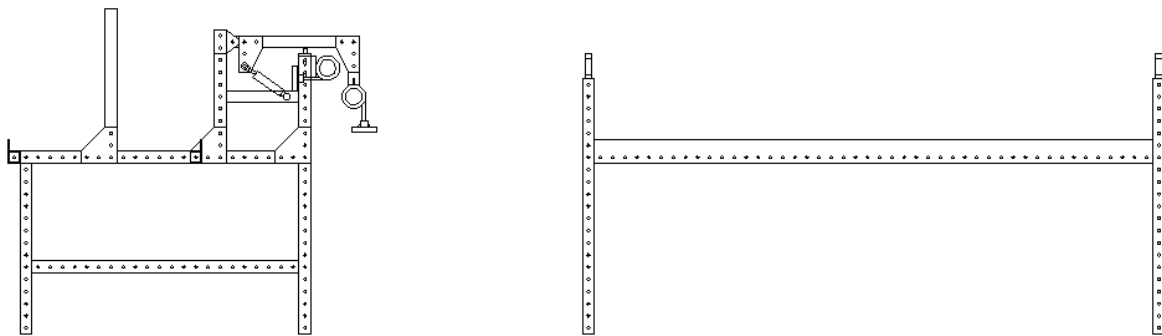

Step 3: Bolt long square tube to side frames using (2) 3-1/2" hex bolts, (4) flat washers, and (2) nylon lock nuts. **NOTE: POSITION TUBE DIRECTLY BELOW FRONT LONG RAIL TUBE.**

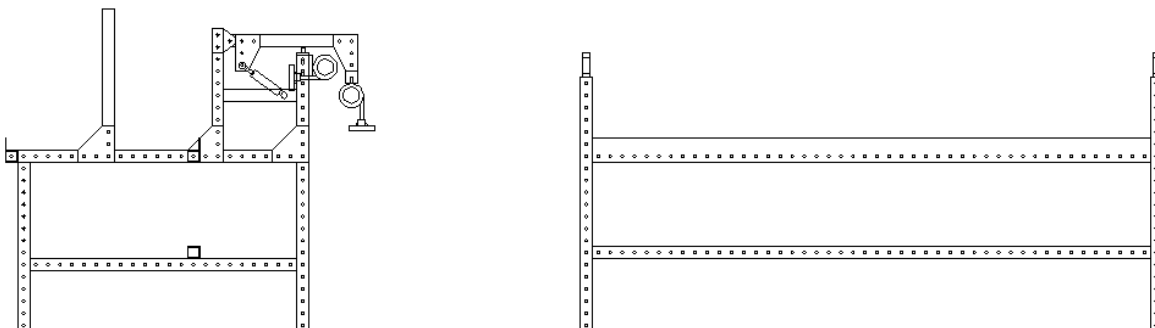

Step 4: Install (1) standard cross block (2 total) into each end of the 21" tube using (1) 3-1/2" hex bolt and (1) flat washer. **NOTE: DO NOT INSTALL A WASHER OR A NUT ONTO THE BOLT STICKING OUT OF THE TUBE. INSTALL SO THAT HEX HEADS ARE FACING THE SAME DIRECTION ON EACH END.**

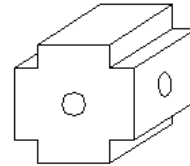
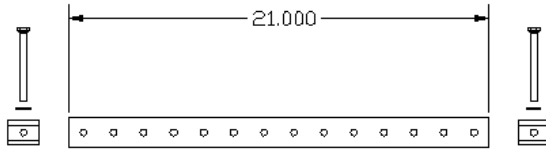

STANDARD
CROSS BLOCK

Step 5: Install (2) 22.5" tube onto the 3-1/2" bolts on each end of the 21" tube and secure with (1) flat washer and (1) nylon insert lock nut. **SEE PICTURE BELOW FOR CORRECT ORIENTATION.**

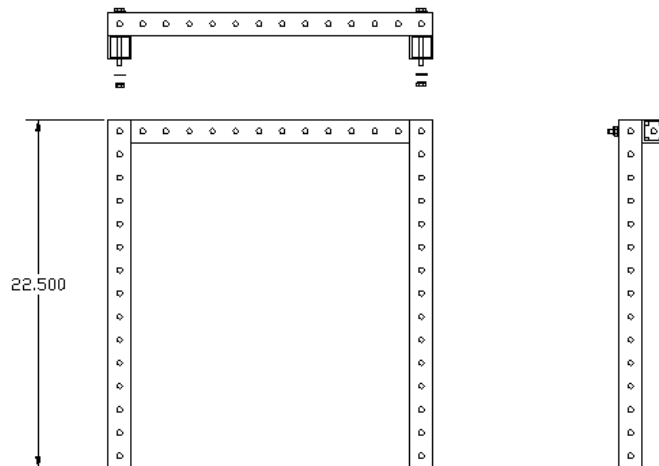

Step 6: Install (1) standard cross block (2 total) into each end of the 18" tube using (1) 2-1/4" hex bolt, (2) flat washer (one per side) and (1) nylon lock nut. **NOTE: INSTALL SO THAT HEX HEADS ARE FACING THE SAME DIRECTION ON EACH END.**

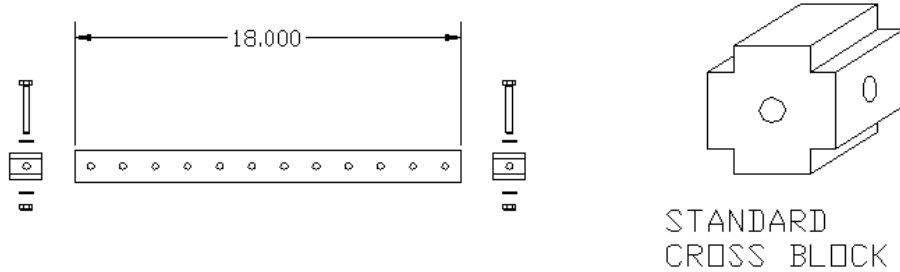

Step 7: Install 18" tube into 8th hole from the top of the 22.5" tubes. Use (2) 2" hex bolts and (2) flat washers. The center leg assembly is now complete.

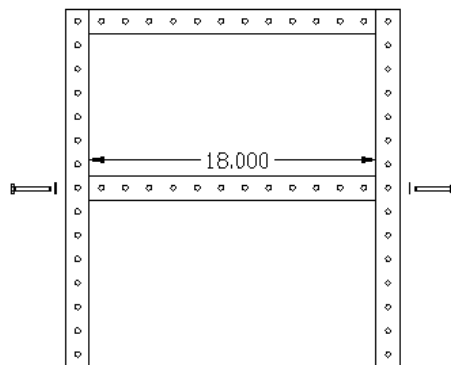

Step 8: Install the center leg assembly at approximately the center of the rail. Use (1) 3-1/2" hex bolts, (2) flat washers, and (1) nylon lock nut to attach the assembly to the lower beam. Use (2) 2" hex bolts and (2) flat washers to attach the assembly to the top rails.

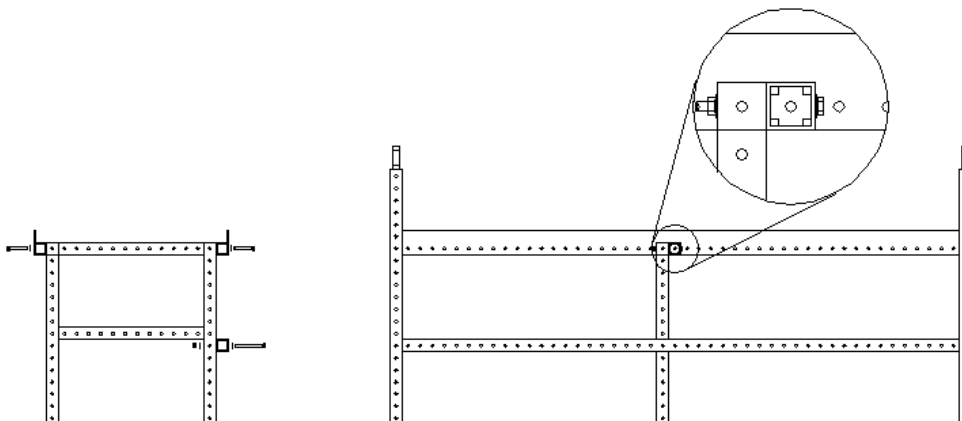

Step 9: Install the (2) 20.875" round bar spacers with (1) 1/8" thick steel shim on each bar between the upper rails 9 holes from either end. Use (2) 2" hex bolts and (2) flat washers per spacer.

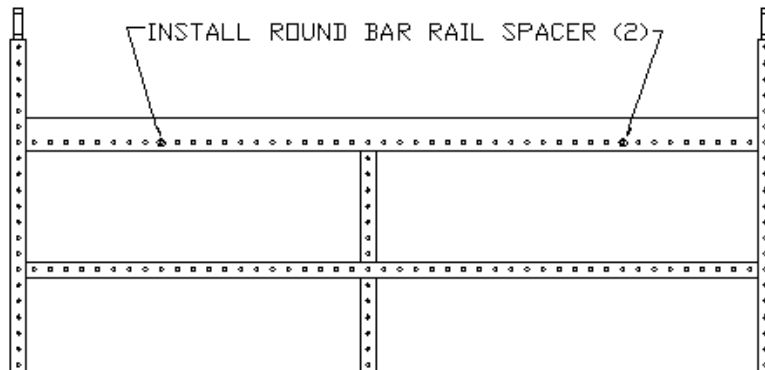

Step 10: Install (4) steel straps to lower tube and upper rail tube using (6) 2-1/4" hex bolts, (12) flat washers, and (6) nylon lock nuts. See drawing for hole locations.

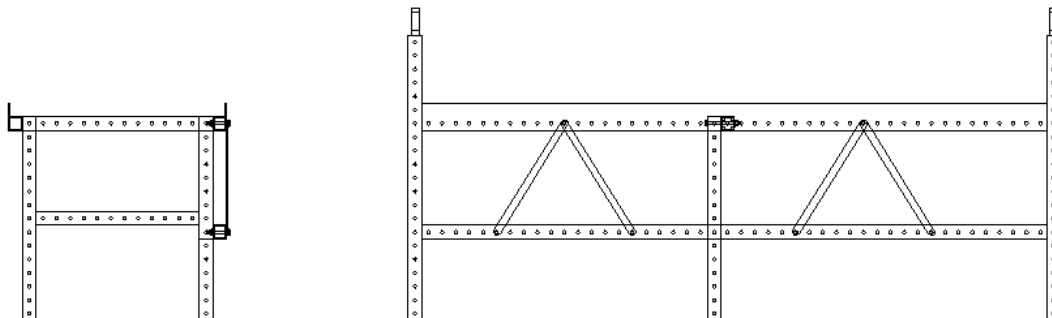

Step 9: Square long rail tubes to lower carriage assembly. Insure that rails ride in the center of the wheels for smoothest performance. If rail to wheel relationship is consistent down the entire length of rail, adjust the front carriage wheel mount. If the rail to wheel relationship differs as the carriage moves down the rail, adjust the long rail tubes at either end by loosening and repositioning the ends or by adding washers to the 21" center tube.

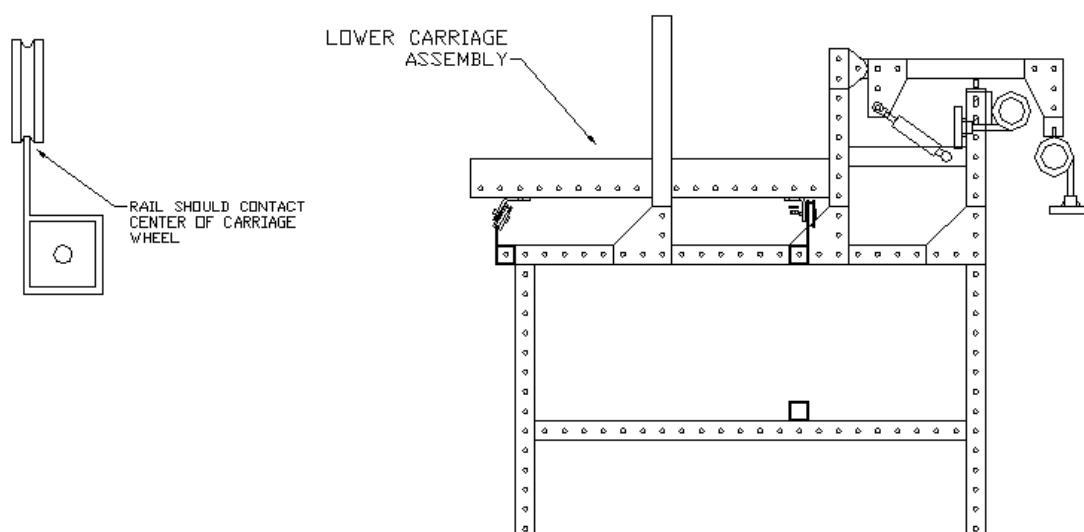

Step 10: Install the rear long rail tube steel gusset straps using (2) 2-1/4" hex bolts, (4) flat washers and (2) nylon lock nuts. See illustration for proper location and orientation.

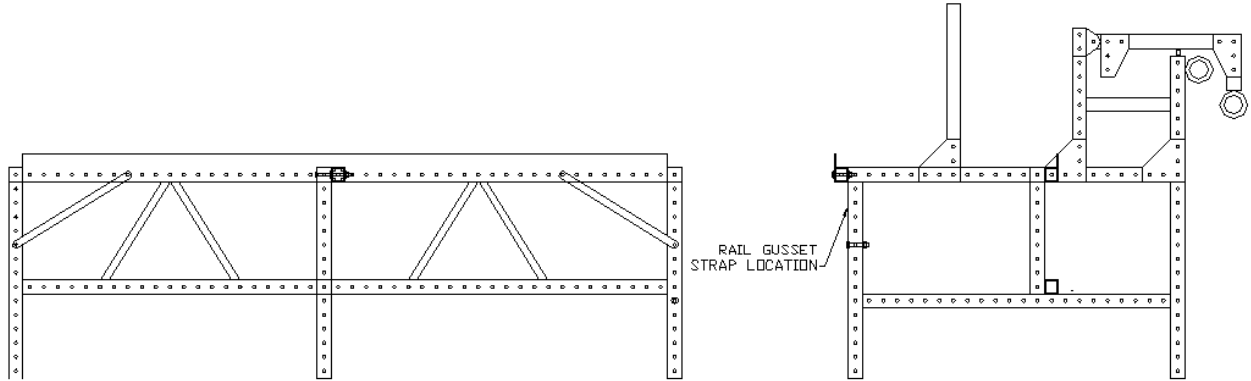

Step 11: Install the take up and bed roller mounts onto the 20.5" vertical beam.

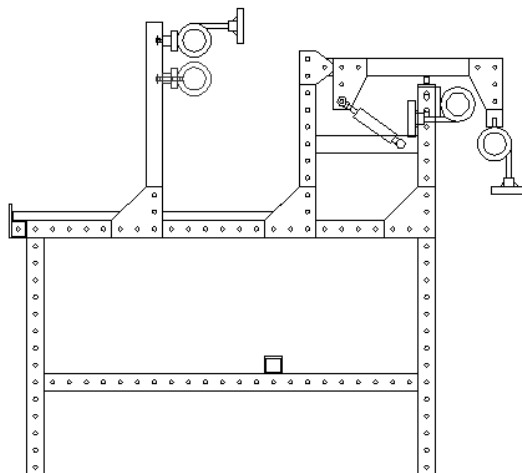

Step 12: Install the (4) rollers into the roller mount locations. Adjust the bed roller mount so that the roller does not rub on the bed of the sewing machine as it passes underneath.

Step 13: Install (8) roller collars as illustrated below.

NOTE: LIGHTLY TIGHTEN ROLLER COLLAR SET SCREWS. OVERTIGHTENING COLLARS WILL MAKE ROLLERS HARD TO TURN. THE SET SCREWS SHOULD NOT DIMPLE OR DISTORT THE ROLLER. THE SCREW SHOULD ONLY BE TIGHT ENOUGH TO KEEP THE COLLAR FROM FALLING OFF OF THE ROLLER.

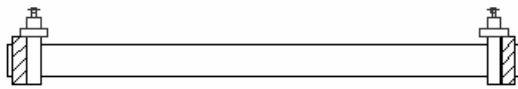

NOTE: COLLARS INSTALLED ON EITHER SIDE OF THE STATIONARY COLLAR LOCATED OPPOSITE OF THE COLLAR WITH HANDWHEEL



Step 14: Install 1" rubber tape onto the bottom and sides of the long rail tubes. Keep rubber tape away from edge of rail where wheel rides. If the wheel contacts the rubber tape, poor rolling performance may result.

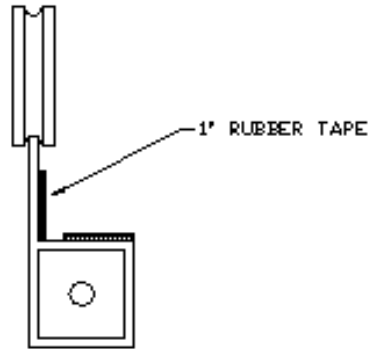

Step 15: Install machine leg assemblies onto frame. Use (2) 3-1/2" hex bolts, (4) flat washers and (2) nylon lock nuts per assembly

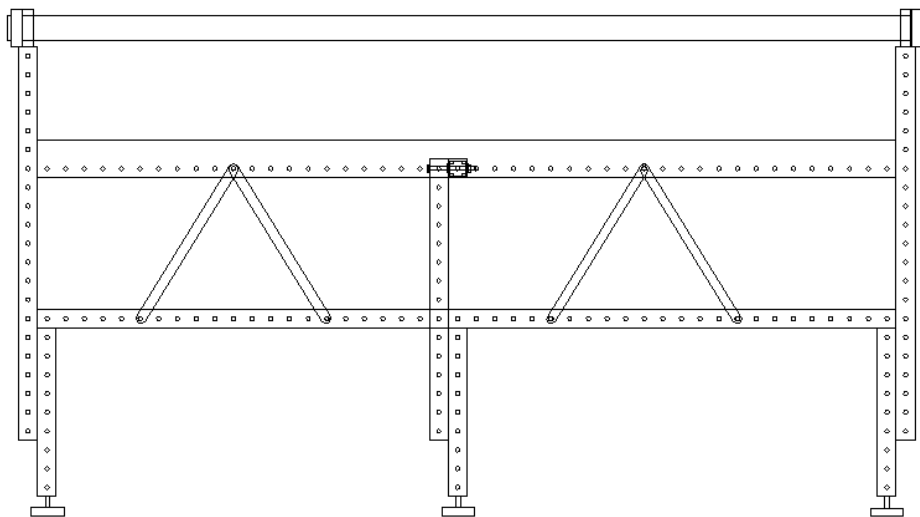

Step 16: Install table top between the long rail tubes. Table should fit smoothly. Table should not be forced in between rails or damage may occur.

Step 17: Install the sewing machine onto lower carriage assembly.

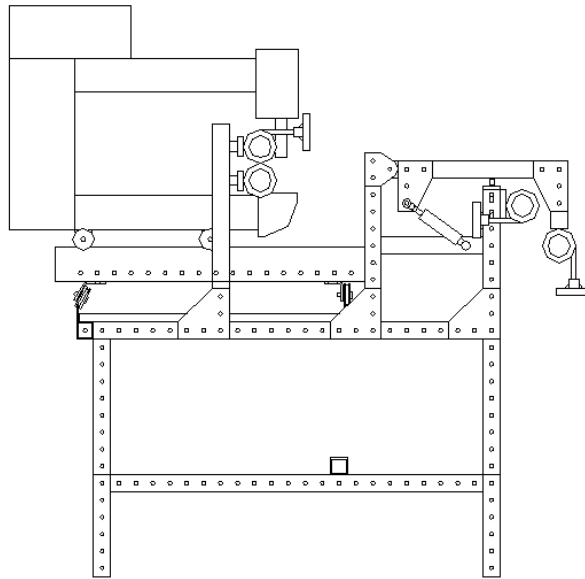

Step 18: Install rubber bumpers onto 20.5" slotted beam on side of beam facing carriage assembly. Use (1) #10 x 3/4 socket head cap screw and (1) #10 t-nut. Adjust position of bumper so carriage contacts the bumper before hitting the end of frame. Install one bumper on each end.

Step 19: Install the plastic side clamp and cord onto each end using the elastic cord clip to adjust the cord length.

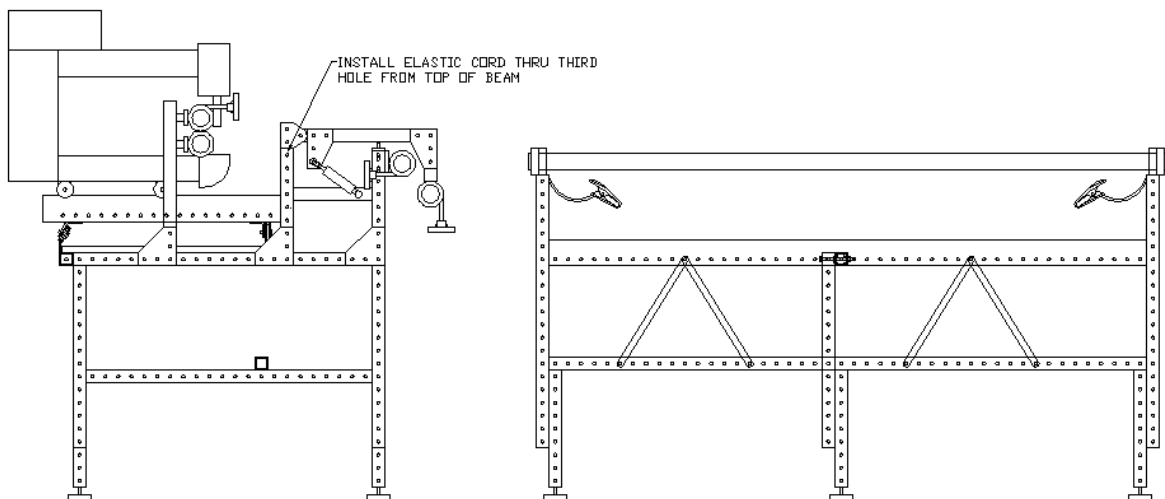

18" Pro-frame axis locks -

(2) Red knob

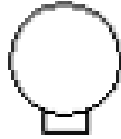

(2) Swivel base



(1) 3-1/2" Threaded stud



(1) 4" Threaded stud



Step 1: Install the (2) red knobs onto one end of both threaded studs.

Step 2: Screw the 4" threaded stud through either the left or right side threaded hole on the lower carriage bracket with 4 wheels. Install (1) swivel base onto the bottom of the 4" threaded stud.

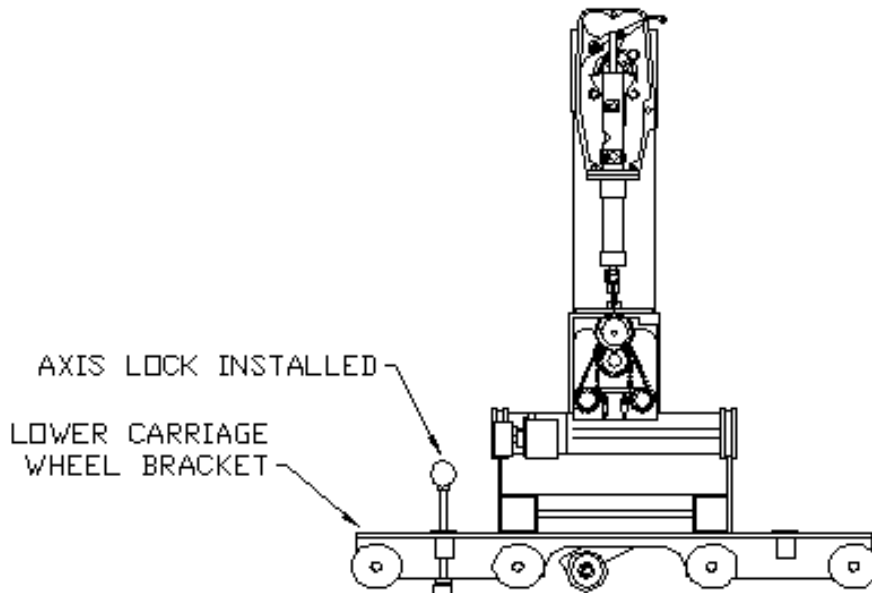

Step 3: Screw the 3-1/2" threaded stud through the threaded hole located on the right side of the rear aluminum wheel beam. Install (1) swivel base onto the bottom of the 3-1/2" threaded stud

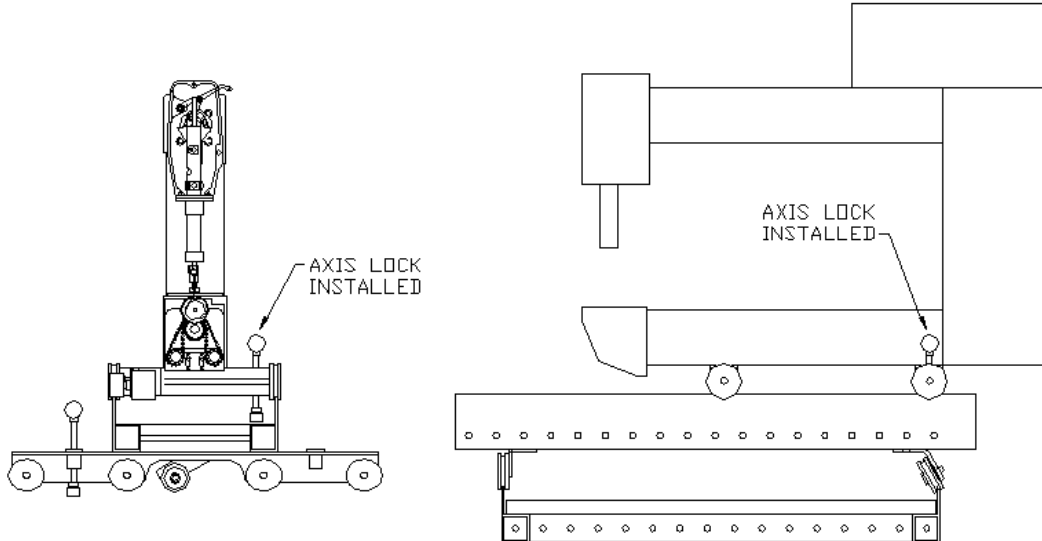

Operational instructions:

Screwing the lower axis lock down until the swivel base makes contact with the table top makes the machine resist rolling left or right.

Screwing the upper axis lock down until the swivel base contacts the lower carriage makes the machine resist rolling forward or back

**ONLY IF EQUIPPED:
18" Pro-frame stitch regulator installation –**

OPTIONAL – Please skip this section if the machine was purchased without stitch regulation.

The machine uses two wheel encoders, see figure below, to track the motion of the machine when stitch regulation is active. For shipping purposes, the encoders are wired into the machine but not attached to the sewing head or the lower carriage. Follow the steps below to properly install the stitch regulator.

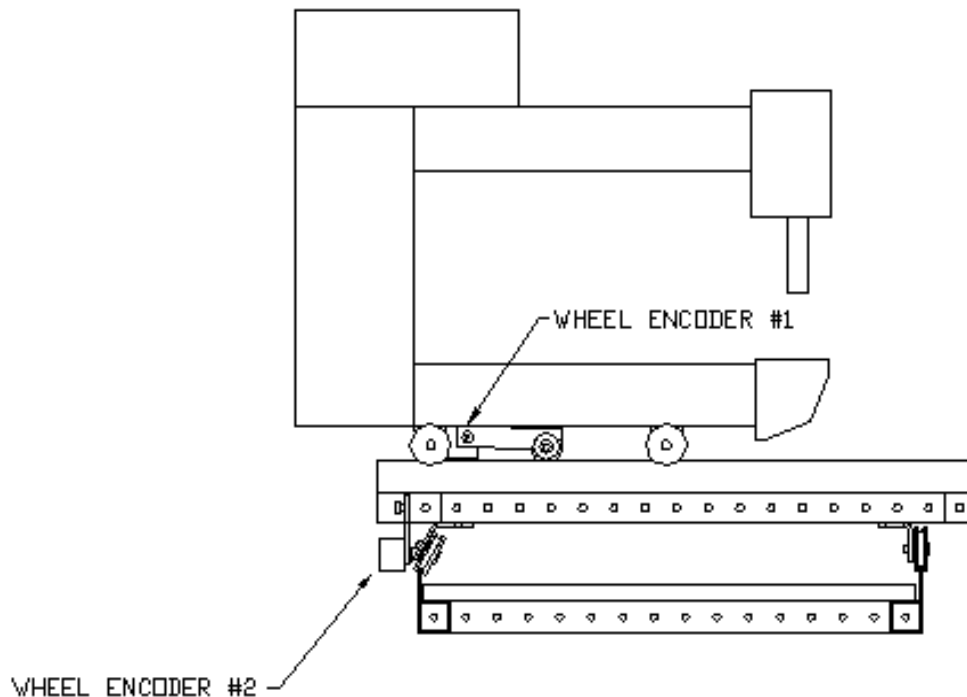

The wheel encoders were designed to be installed in specific locations. The picture below shows the encoders as they are found wired to the sewing head.

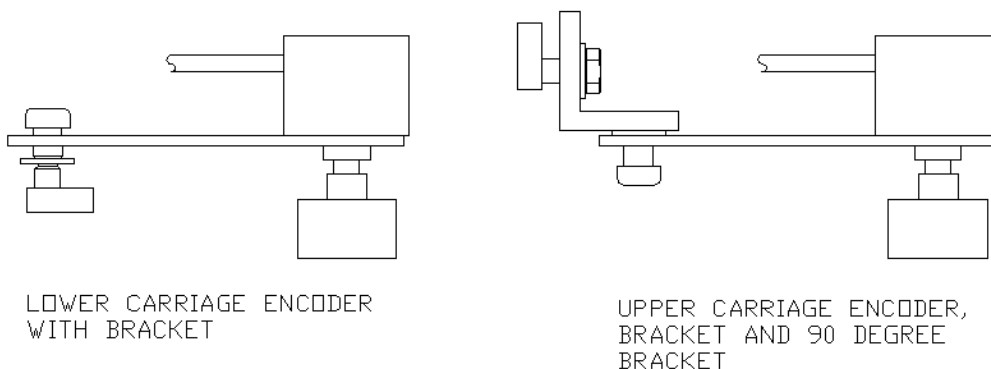

Step 1: Install the upper carriage wheel encoder and 90 degree bracket onto the rear aluminum wheel beam of the sewing head with the supplied bolt and nut. **NOTE: REMOVAL OF THE REAR WHEEL MAY BE NECESSARY TO INSTALL THE NUT.**

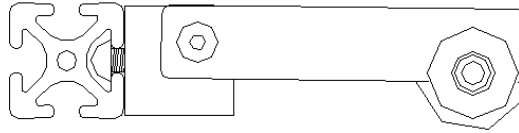
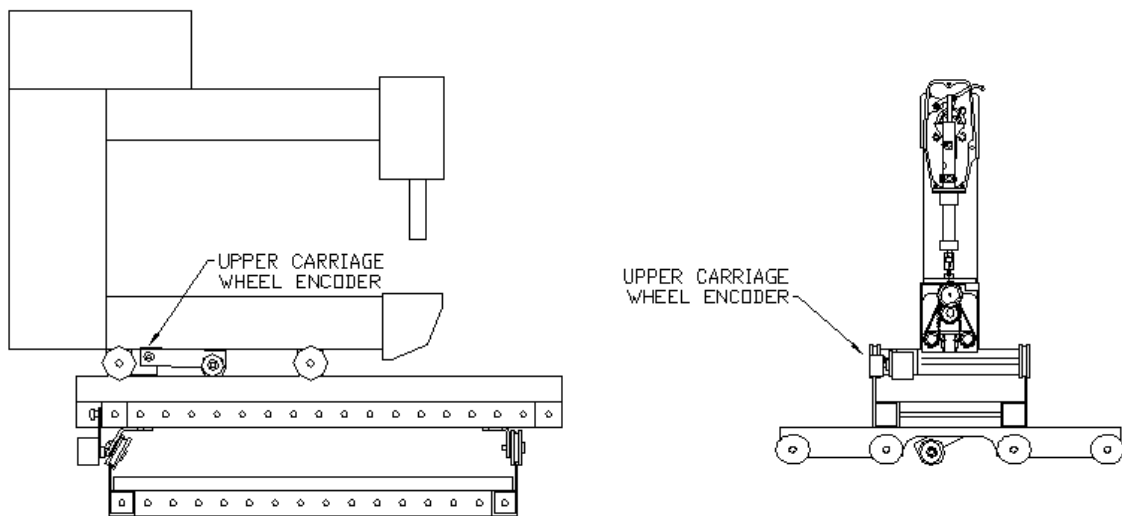

Figure above: Close up view of encoder installed in rear aluminum wheel beam.



Step 2: Install the lower carriage wheel encoder onto the rear aluminum beam of the lower carriage with the supplied bolt and nut. **NOTE: REMOVAL OF THE BEAM MAY BE NECESSARY TO INSTALL THE NUT.**

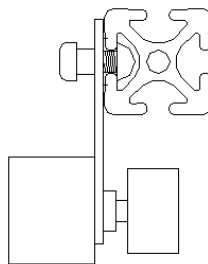
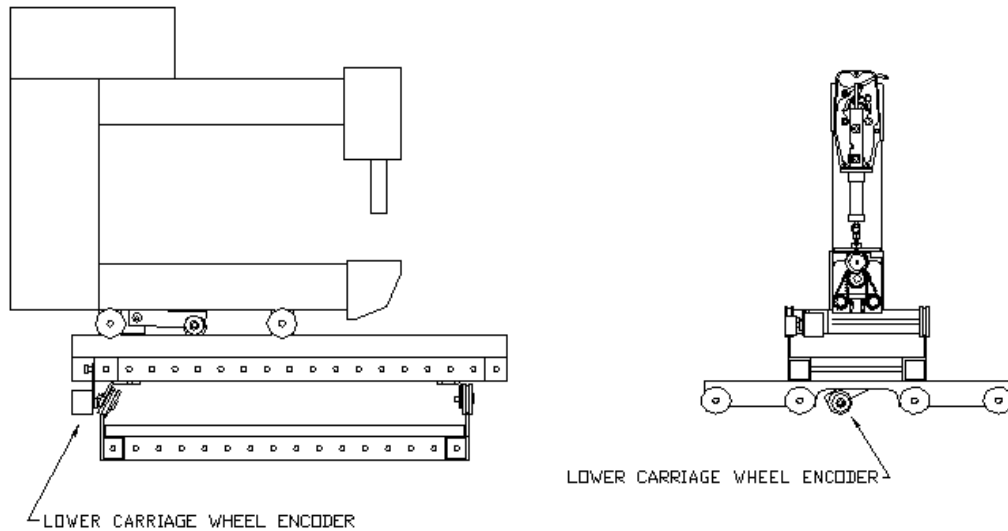

Figure above: Close up view of lower carriage wheel installed on beam.



Step 3: Confirm that the upper and lower wheels ride on the same flange that the plastic wheels of the sewing machine and lower carriage roll on.

Step 4: Confirm that the electrical cable of the lower carriage encoder has enough slack to allow sufficient movement front to back without getting stretched. Install the 1/4 turn wire mount into the top channel of the lower carriage rear beam and nylon tie the main power and lower encoder cable to it. **NOTE: BE SURE TO LEAVE ENOUGH SLACK ON THE ENCODER CABLE WHEN NYLON TYING SO THAT THE ENCODER WHEEL MAKES PROPER CONTACT WITH THE FLANGE. IF THE CABLE IS TOO TIGHT, THE ENCODER WHEEL WILL NOT ROLL PROPERLY CAUSING STITCH REGULATION PROBLEMS.**

