

18" Pro-frame Parts List -

Structural frame profiles –

Perforated square tube:



- (Qty. 1) Frame size in inches (i.e. 6' frame = 72", except 12' = 141")
- (Qty. 2) 36"
- (Qty. 2) 34.5"
- (Qty. 2) 33"
- (Qty. 2) 22.5"
- (Qty. 2) 21"
- (Qty. 1) 18"
- (Qty. 2) 15"
- (Qty. 6) 13.5"

Perforated rail tube:

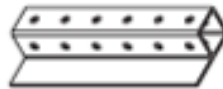

- (Qty. 2) Frame size in inches minus 3" (i.e. 6' frame = 69", except 12' = 138")
- (Qty. 2) 30.0"

Slotted beam:



- (Qty. 2) 6"
- (Qty. 2) 9"
- (Qty. 2) 15.75"
- (Qty. 2) 20.5"

Round bar rail spacer:

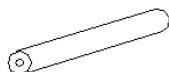

- (Qty. 5) 20.875"

Commercial Parts -

Lower carriage rear wheel assembly (Qty. 1)

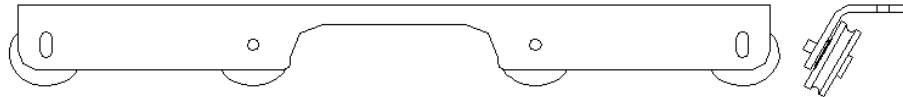

Lower carriage front wheel assembly (Qty. 1)

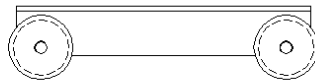

Liner roller and take-up roller end plate with gear assembly (Qty. 2)

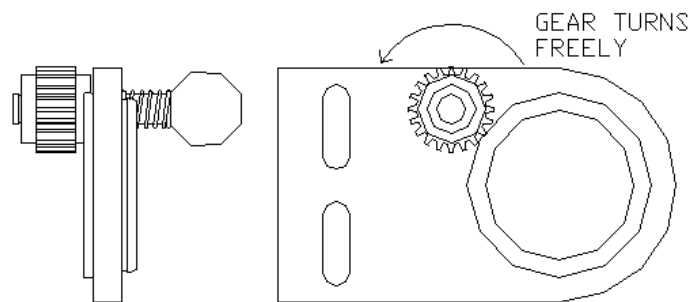

Liner roller, take-up roller, and bed roller end plate (Qty. 4)

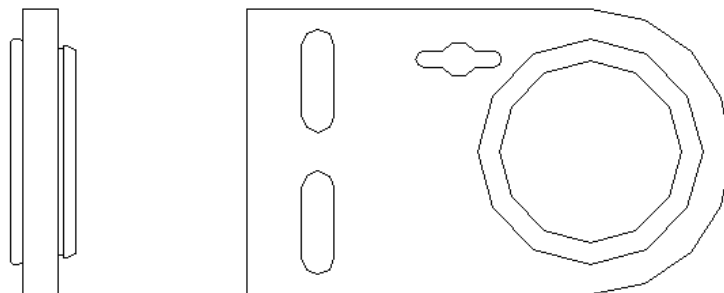

Top fabric roller end plate with gear assembly (Qty. 1)

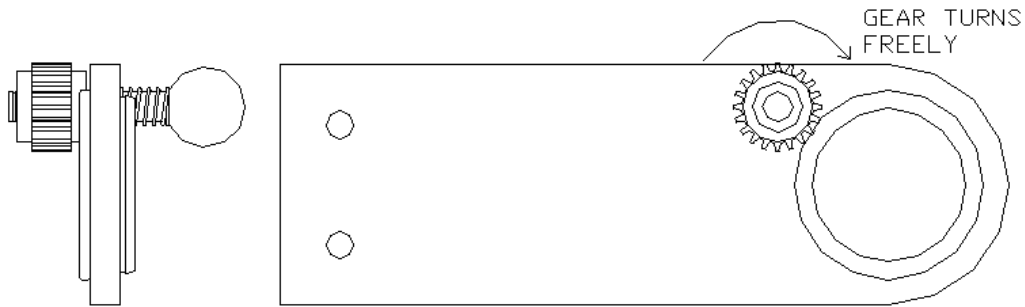

Top fabric roller end plate (Qty. 1)

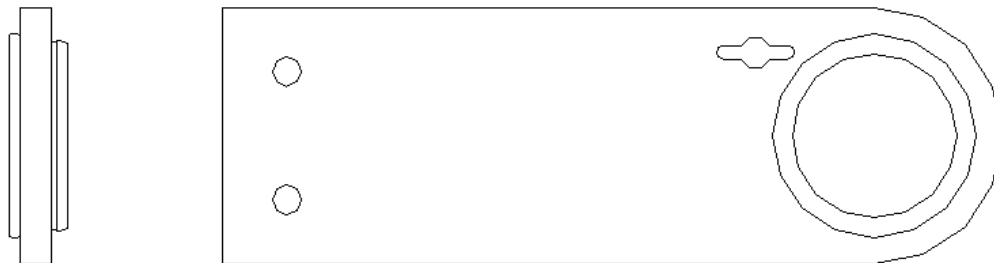

Roller collar (Qty. 5)

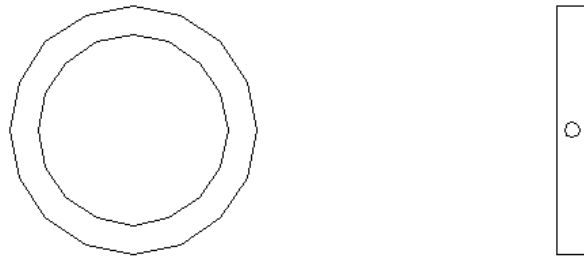

Roller gear (Qty. 3)

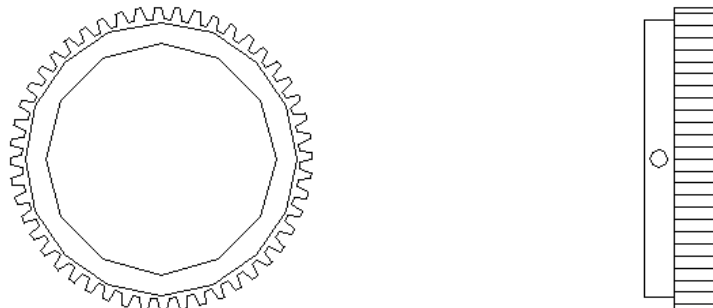

Roller tube (Qty. 4) – Frame size plus 2 inches (i.e. 6' = 74")



Steel strap (Qty. 6)



Plastic clamp with elastic cord (Qty. 2)

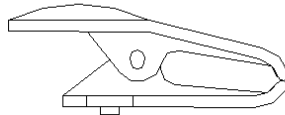

Pivot arm bracket (Qty. 4)

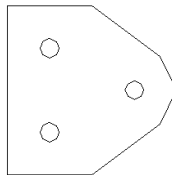

Gas spring with ball stud mounts (Qty. 2) *pictured with ball studs installed*



Pivot arm shoulder bolt and plastic washer (Qty. 4 each)



Large rubber bumper (Qty. 2)



Rubber tape roll (Qty. 1 roll)



Roller end cap (Qty. 8)



Small rubber cap (Qty. 2)



Elastic cord clip (Qty. 2)



Table tops (Qty. dependant on machine size)

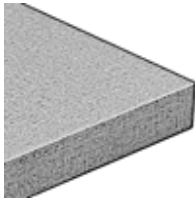

5 hole gusset plate (Qty. 6)



4 hole gusset plate (Qty. 2)



Pivot nub (Qty. 2)



Standard cross block (Qty. 14)



Extended cross block (Qty. 6)



5/16 Double T-nut (Qty. 10) *pictured with bolts installed*



5/16 T-nut (Qty. 2) *pictured with bolt installed*



#10 T-nut (Qty. 2) *pictured with bolt installed*



Machine foot (Qty. 6)



Tubing end cap (Qty. 18)



Beam end cover (Qty. 4)



1/8" Thick steel shim (Qty 5)



Commercial Parts -

Bolt kit –

Hex head cap screw:



(Qty. 6) 5/16 x 1/2"
(Qty. 30) 5/16 x 3/4"
(Qty. 14) 5/16 x 1"
(Qty. 40) 5/16 x 2"
(Qty. 66) 5/16 x 2-1/4"
(Qty. 8) 5/16 x 2-1/2"
(Qty. 26) 5/16 x 3-1/2"

Socket head cap screws:



(Qty. 2) #10 x 3/4"

Flat washers:



(Qty. 200) 5/16

Lock washers:



(Qty. 50) 5/16

Nylon insert lock nuts:



(Qty. 100) 5/16

Hex nuts:



(Qty. 20) 5/16

18" Pro-frame machine leg assembly –

NOTE: MAKE (6) PIECES

Step 1: Install hex nut onto each of the (6) machine feet. Screw nut all the way down to the top of the flat on threaded foot.

Step 2: Install (1) flat washer onto each of the (6) machine feet.

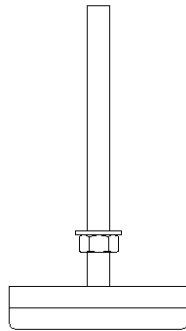

Step 3: Install machine feet into (6) extended cross blocks. Note only one end of extended cross block is threaded.

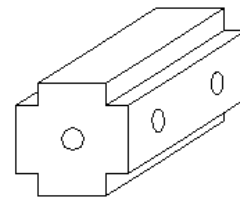
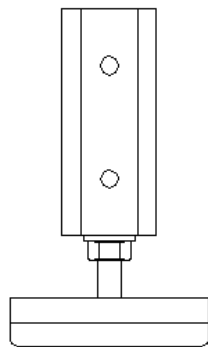

EXTENDED
CROSS BLOCK

Step 4: Install foot assembly into (6) 13.5" long tubes. Use (1) 2-1/4" hex bolt, (2) flat washers (one per side), and (1) nylon insert lock nut per assembly

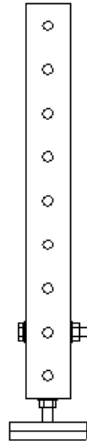

Step 5: Install (1) 1/2" hex bolt with (1) flat washer into the side of each leg assembly.

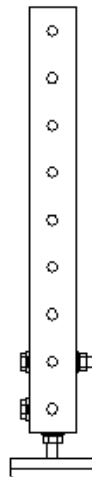

Step 6: Install (1) tubing end cap into the open end of each foot assembly.

Step 7: Tighten all bolts, set aside.

18" Pro-Frame side rail support assembly –

IMPORTANT NOTE: Take care not to over-tighten nuts and bolts while assembling the aluminum Pro-frame. Unnecessary over-tightening will cause the frame pieces to twist and distort.

NOTE: MAKE ONE LEFT AND ONE RIGHT HAND ASSEMBLY.

Step 1: Install a standard cross block (2 total) into each end of the 33" tube using (1) 2-1/4 hex bolt, (2) flat washer (one per side) and (1) nylon insert lock nut. **NOTE: INSTALL THE BOLTS SO THE HEX HEADS ARE FACING THE SAME DIRECTION.**



Step 2: Install a standard cross block into one end of the 21" tube using (1) 2-1/4 hex bolt, (2) flat washer (one per side) and (1) nylon insert lock nut.



Step 3: Bolt 21" tube onto 36" tube through 2nd hole from one end. Use (1) 2" hex bolt and (1) flat washer. **NOTE: FOR A BETTER APPEARANCE, KEEP ALL BOLT HEADS ON SAME SIDE.**

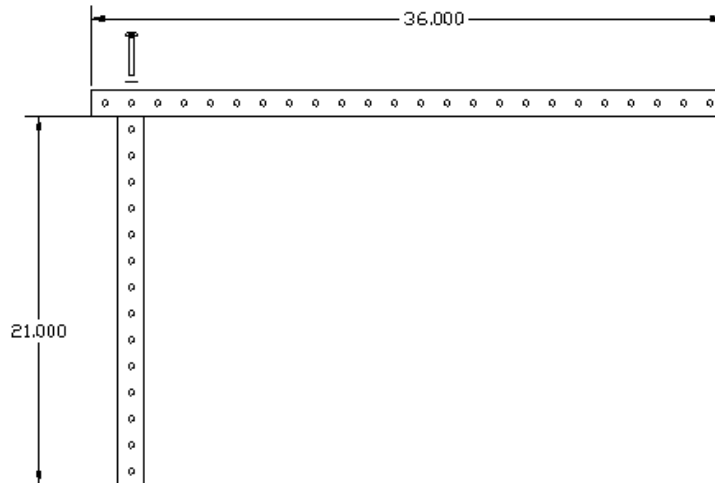

Step 4: Bolt 33" tube, from step 1, to 21" tube (9) holes down from connection to 36" tube. Use (1) 2" hex bolt and (1) flat washer.

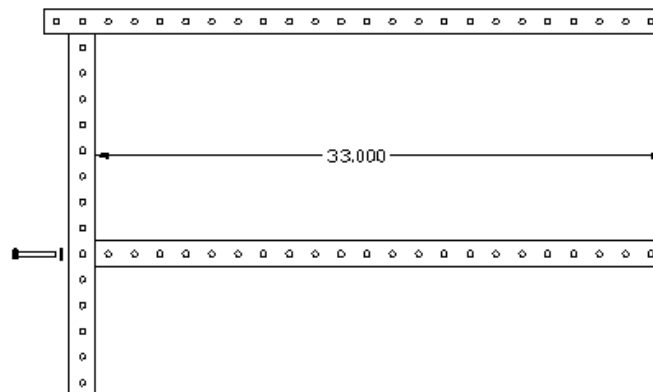

Step 5: Install 34.5" tube onto open end of 33" tube. Install into 6th hole from one end of 34.5" tube. Use (1) 2" hex bolt and (1) flat washer.

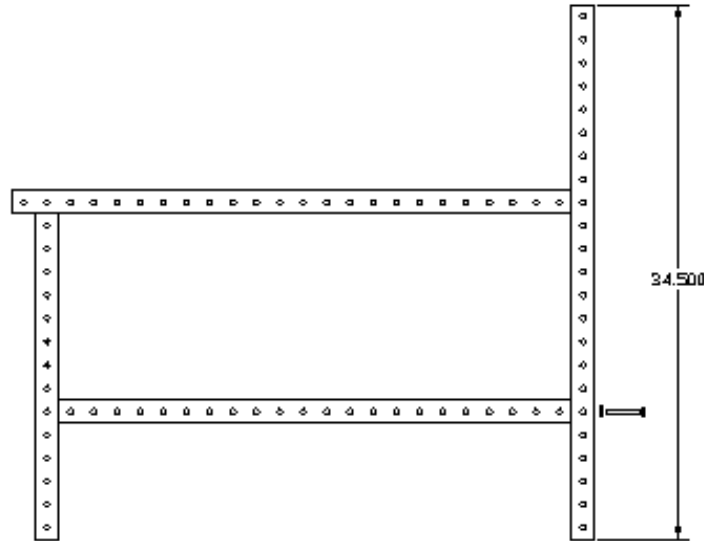

Step 6: Using (1) 5 hole gusset plate attach 36" tube to 34.5" tube. Use (5) 2-1/4" hex bolts, (10) flat washers (one per side) and (5) nylon insert lock nuts. **NOTE: MAKE SURE TO ASSEMBLE (1) LEFT AND (1) RIGHT ASSEMBLY.**

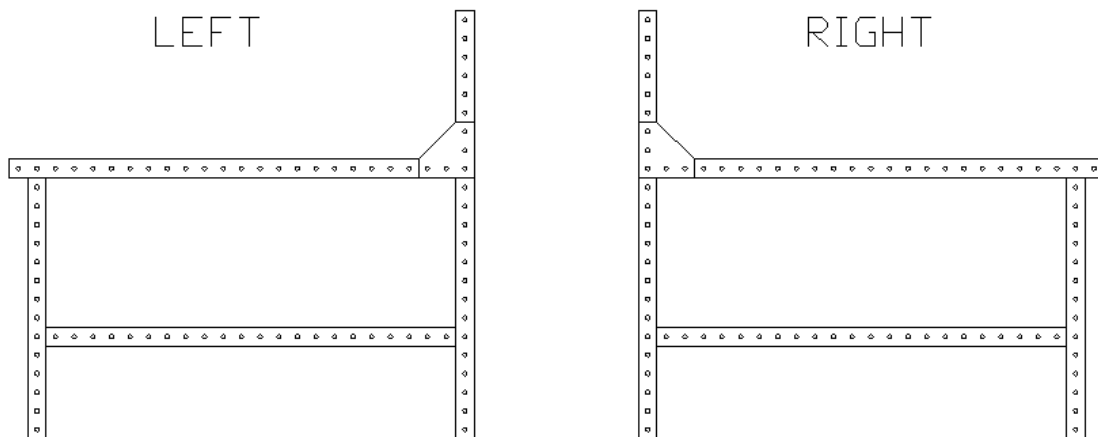

Step 7: Using (1) 5 hole gusset plate attach 20.5" slotted beam to 36" tube. Beam should mount through 9th hole from open end of 36" tube. Use (3) 2-1/4" hex bolts, (6) flat washers (one per side) and (3) nylon insert lock nuts to attach gusset plate to perforated square tubing. Place (2) 3/4" hex bolts with (2) lock washers (one on each bolt) in the open holes of the gusset plate. On the opposite side, attach (1) 5/16 double T-nut with the bumps facing away from the gusset plate. Slide the 20.5" slotted beam onto the T-nuts and tighten. **NOTE: MAKE SURE TO ASSEMBLE (1) LEFT AND (1) RIGHT ASSEMBLY**

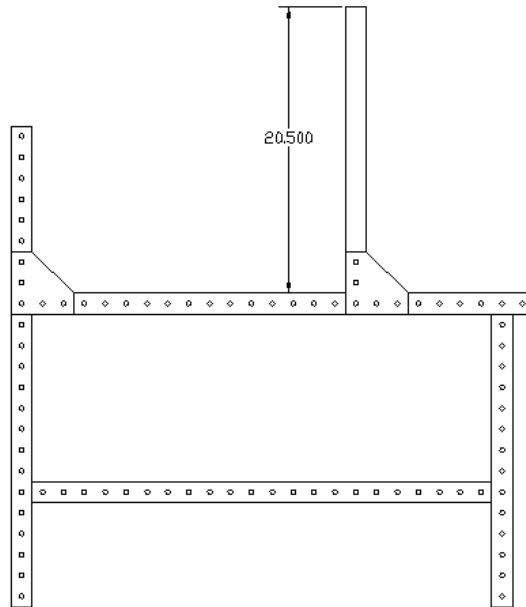

Step 8: Using (1) 5 hole gusset plate attach 15" perforated tube to 36" tube. 15" Tube should mount so that there are 4 open holes between the 5 hole gusset plates as in the picture below. Use (4) 2-1/4" hex bolts, (8) flat washers (one per side) and (4) nylon insert lock nuts. **NOTE: MAKE SURE TO ASSEMBLE (1) LEFT AND (1) RIGHT ASSEMBLY**

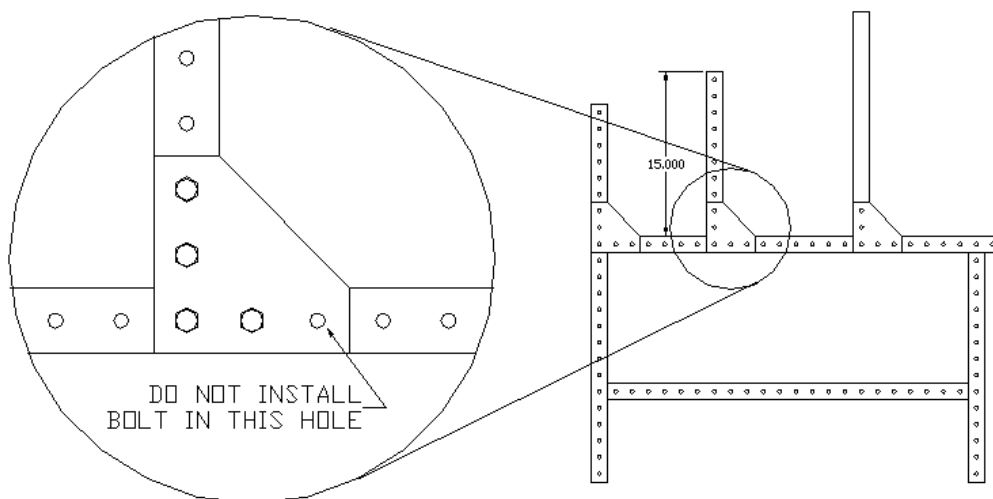

Step 9: Slide (1) 5/16 T-nut into any side slot of the 9" slotted beam. Install (1) 9" slotted beam between 15" tube and 34.5" tube through the 6th hole from open end of 15" tube. Use (2) 2" hex bolt and (2) flat washers. Position the 9" beam so that the slot with the T-nut faces the same direction as the 5 hole gussets.

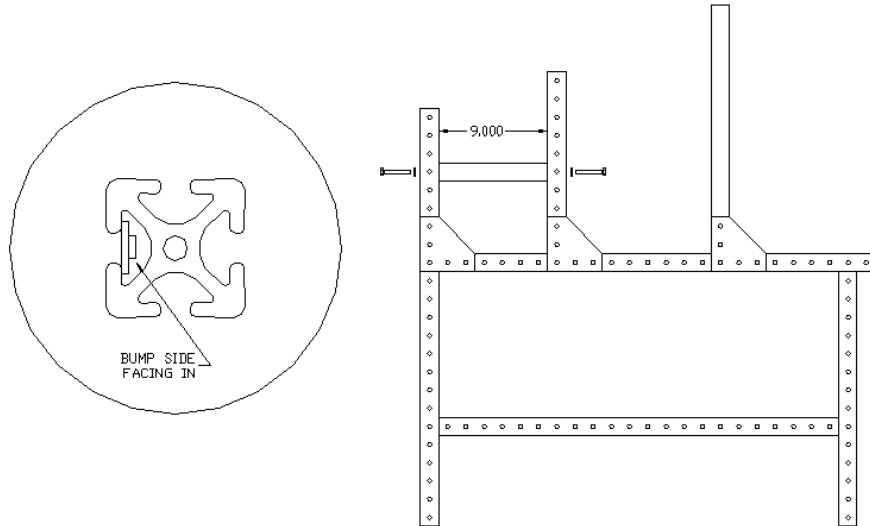

Step 10: Install the liner roller end plate with gear assembly onto top end of 34.5" tube (also install a standard cross block into the end of the tube). Install the liner roller end plate as high as possible so that the bolt heads are at the bottoms of the plate slots. Use (2) 2-1/2" hex bolt, (4) flat washers, (2) nylon insert lock nuts. The balloon on the left illustrates how to install the standard cross block into the tube end. The balloons on the right show a top view of the 34.5" tube with the liner roller support bracket installed correctly. **NOTE: THE LINER ROLLER END PLATES ARE ORIENTED DIFFERENTLY DEPENDING ON WHICH END YOU ARE WORKING ON. THE END PLATE WITH THE GEAR ASSEMBLY MUST BE INSTALLED ON THE RIGHT SIDE. CALL ABM IF YOU WANT TO MOUNT THE GEAR ASSEMBLY ON THE LEFT END.**

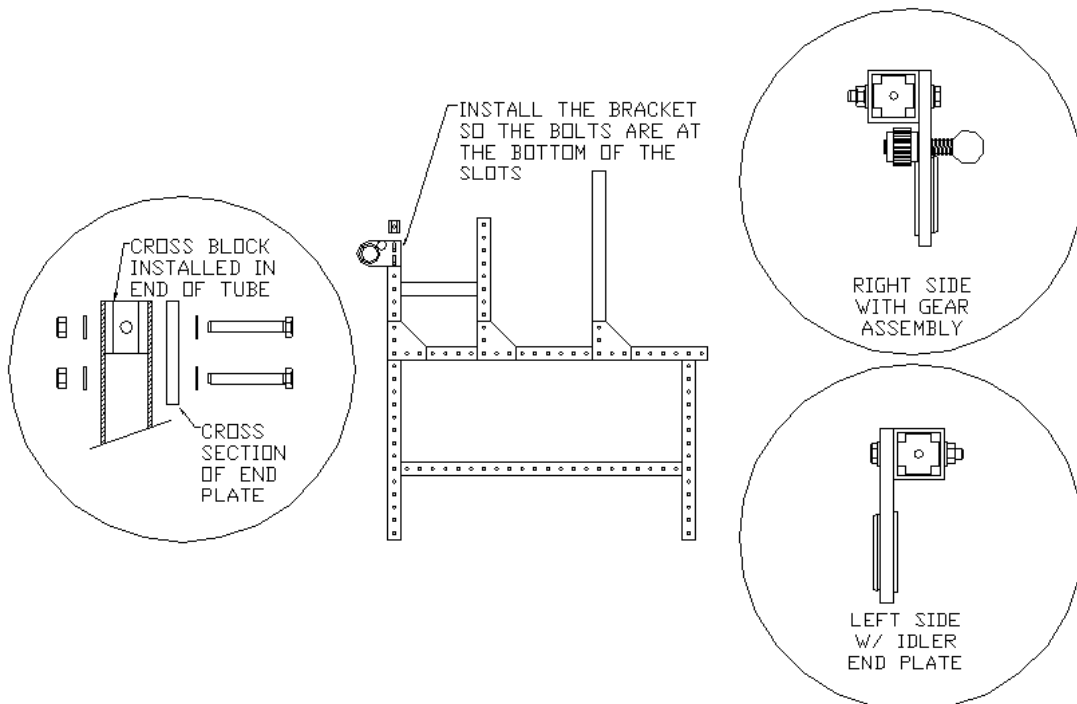

Step 11: Install (1) 1" hex bolt, (1) hex nut, and (1) flat washer into the end of the standard cross block. Install small rubber cap onto head of hex bolt. **NOTE: THE SMALL RUBBER CAP IS A VERY SNUG FIT AND SHOULD BE STARTED ON ONE OF THE POINTS OF THE HEX BOLT HEAD AND ROLLED ONTO THE ENTIRE BOLT HEAD. PRESS DOWN FIRMLY TO MAKE SURE RUBBER CAP HAS SEATED COMPLETELY ON THE BOLT HEAD.**

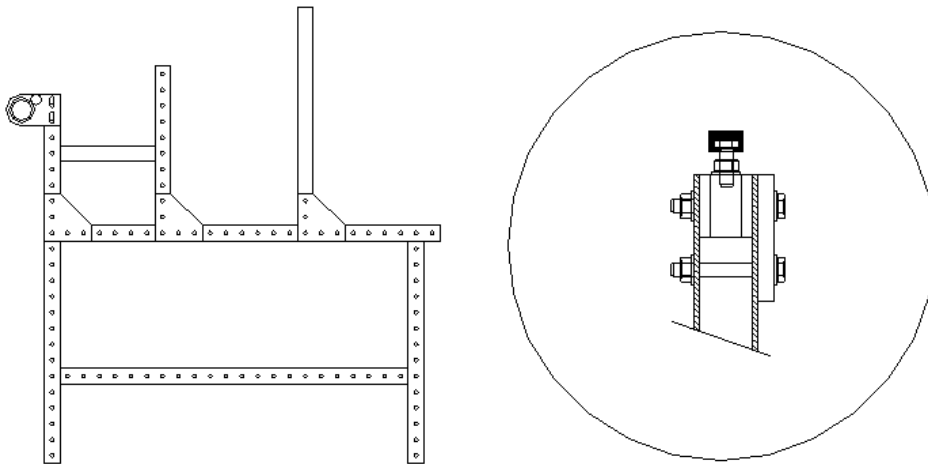

Step 12: Completed pro-frame left and right side rail support assemblies.

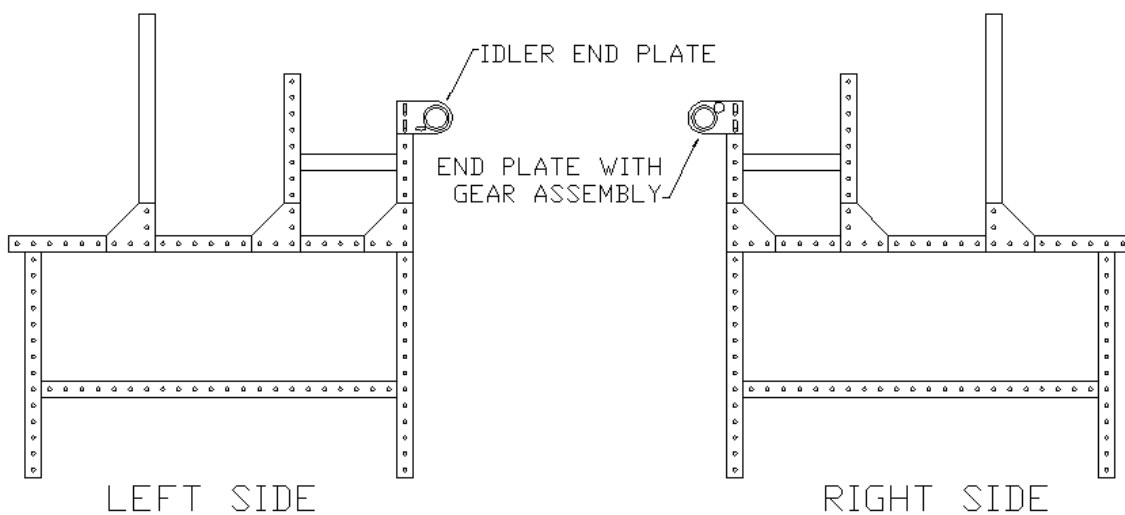

18" Pro-frame pivot roller assembly –

NOTE: MAKE ONE LEFT AND ONE RIGHT HAND ASSEMBLY

Step 1: Install pivot nub onto the threaded end of 15-3/4" slotted beam – only one end of the beam is threaded. Use bolt supplied with the nub. **NOTE: REMOVE THE 5/16 T-NUT AND SAVE.**

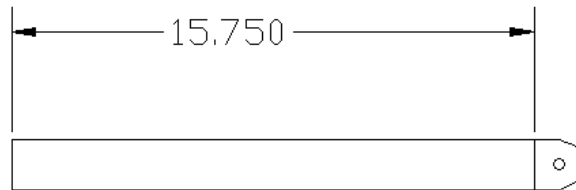

Step 2: Install 4-hole gusset plate onto 15-3/4" slotted beam exactly 1" from end with nub. Use (2) 3/4" hex bolts, (2) lock washers, and (1) double T-nut. **NOTE: MAKE SURE TO ASSEMBLE (1) LEFT AND (1) RIGHT ASSEMBLY**

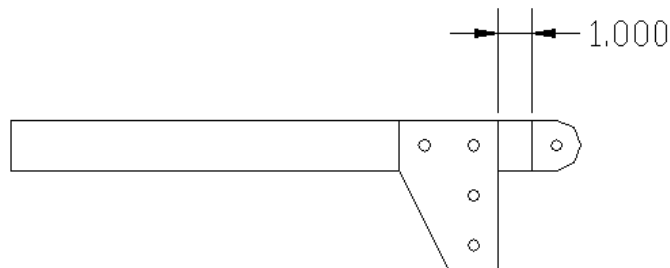

Step 3: Install top fabric roller end plates with and without gear assembly onto open end of 15-3/4" slotted beam - flush to end. Use (2) 1" hex bolts, (2) lock washers, (2) flat washers, and (1) double T-nut. **NOTE: MAKE SURE THE TOP FABRIC ROLLER END PLATE WITH GEAR ASSEMBLY SHOULD BE ON THE RIGHT PIVOT ROLLER ASSEMBLY.**

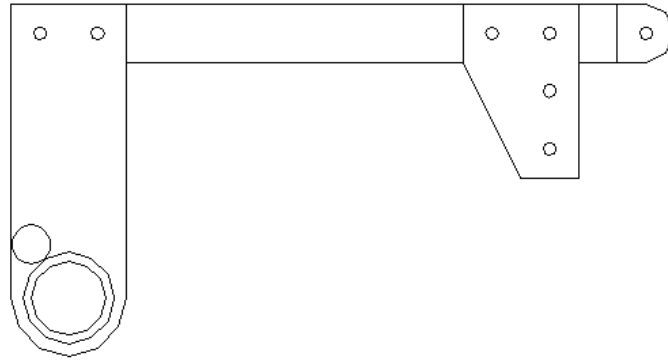

Step 4: Install (2) pivot arm brackets onto nub end. Use (2) pivot arm shoulder bolts and (2) plastic washers. Install plastic washer between pivot arm bracket and pivot nub.

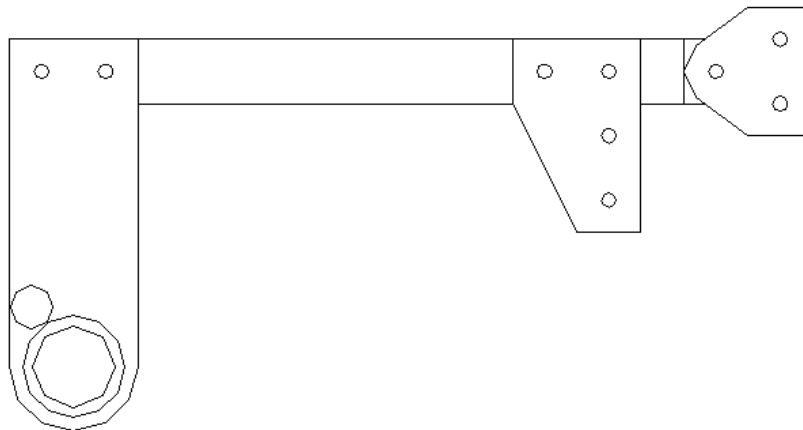

Step 5: Install pivot roller assembly onto 15" perforated tube located on side frame assembly. Use (2) 2-1/2" hex bolts, (4) flat washers, and (2) nylon insert lock nuts. Adjust the height of the rubber capped hex bolt so the 15-3/4" slotted beam is level to the ground.

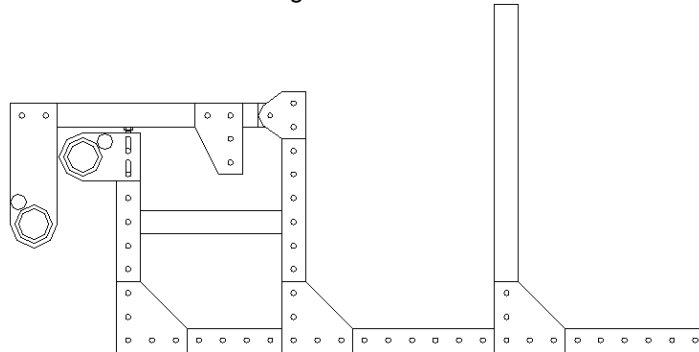

Step 6: Attach one ball stud to 4 hole gusset plate and secure with (1) nylon insert lock nut. Install the other ball stud with a flat washer into 5/16 T-nut located in 9" beam – see illustration for correct position. Make sure to use (1) flat washer between lower ball stud and 9" beam. Tighten lower mount.

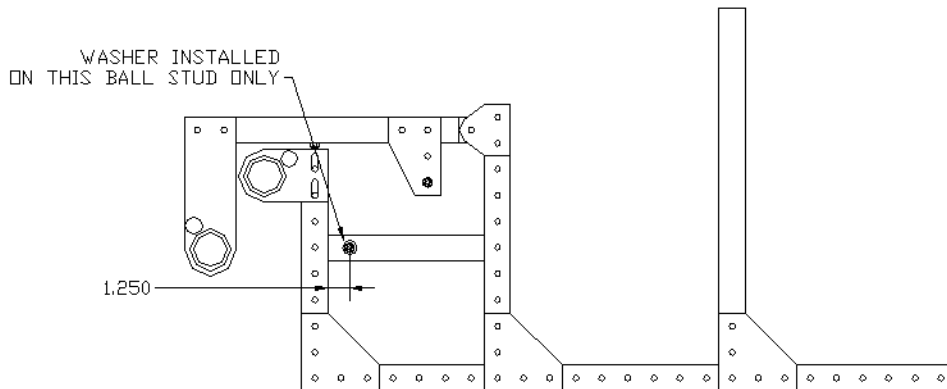

Step 7: Attach the gas springs to frame by firmly pressing the black plastic socket ends onto the ball studs. **NOTE: LIFT THE PIVOT ROLLER ARM TO LINE UP THE SOCKET WITH THE BALL STUDS. IF EVERYTHING IS DONE CORRECTLY, THE ARM WILL STAY IN THE LIFTED POSITION WHEN RAISED AND IT WILL LOCK IN THE LOWER POSITION WHEN LOWERED. IF THE ARM FAILS TO STAY IN THE LIFTED POSITION, MOVE THE LOWER BALL STUD TOWARD THE PIVOT ARM BRACKET SLIGHTLY.**

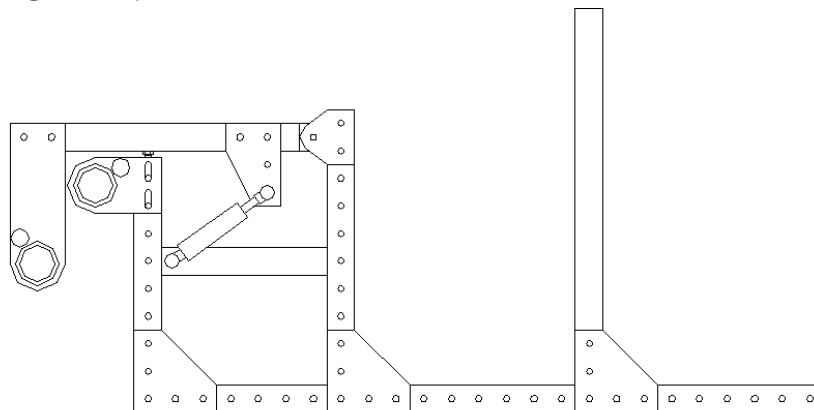

18" Pro-frame lower carriage assembly -

Step 1: Install a 6" slotted beam onto the (2) 30" perforated rail tubes thru 2nd hole from open end. Use (2) 2" hex bolts, (2) flat washers. **NOTE: IF MACHINE IS EQUIPPED WITH STITCH REGULATION, INSTALL (1) 5/16 T-NUT, INCLUDED WITH ENCODER WHEEL BRACKETS, IN THE OUTSIDE CHANNEL OF THE 6" BEAM.**

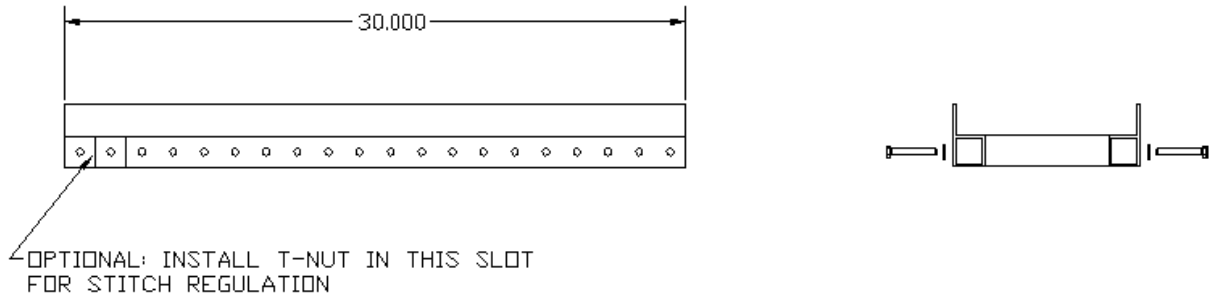

Step 2: Install a second 6" beam onto 30" perforated rail tube. Mount thru 1st hole on opposite end of tube. Use (2) 2" hex bolts and (2) flat washers

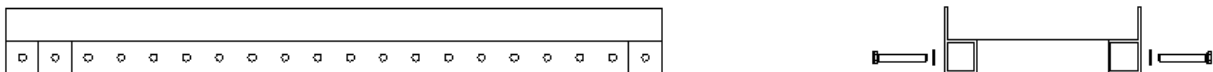

Step 3: Install lower carriage rear wheel assembly onto 30" perforated rail tube thru the 3rd hole from end of tube. Use (2) 2-1/4" hex bolts, (4) flat washers and (2) nylon insert lock nuts. **NOTE: SEE DRAWINGS FOR PROPER BRACKET AND WHEEL ORIENTATION. MAKE SURE TO CHECK FOR SQUARENESS WHEN TIGHTENING THE WHEEL BRACKET TO THE RAILS – USE A COMBINATION OR CARPENTERS' SQUARE IF AVAILABLE.**

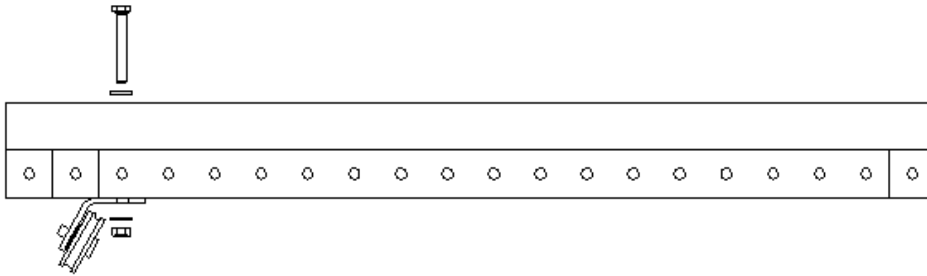

Step 4: Install lower carriage front wheel assembly onto 30" perforated rail tube thru the 4th hole from end of tube. Use (2) 2-1/4" hex bolts, (4) flat washers and (2) nylon insert lock nuts. **NOTE: SEE DRAWING FOR PROPER BRACKET AND WHEEL ORIENTATION.**

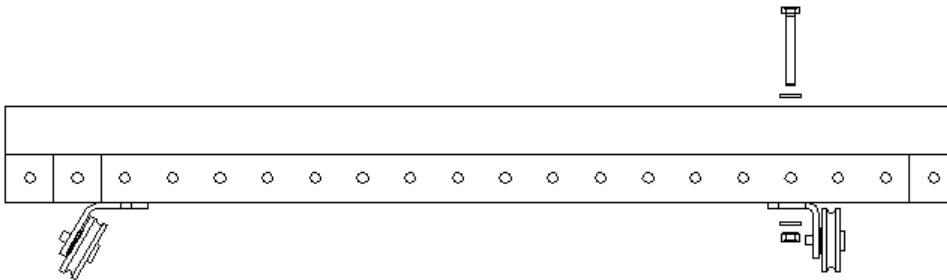

18" Pro-frame final assembly –

Step 1: Install (1) standard cross block (2 total) into each end of the long perforated rail tubes using (1) 2-1/4 hex bolt, (2) flat washer (one per side) and (1) nylon insert lock nut. **NOTE: SEE DRAWING FOR CORRECT BOLT ORIENTATION.**

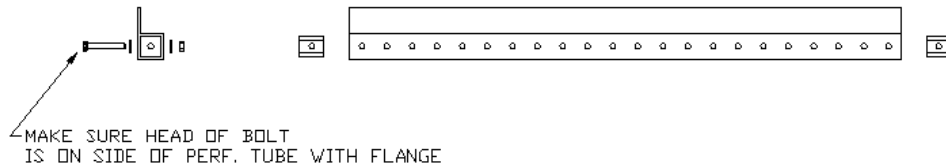

Step 2: Bolt long perforated rail tubes to side rail support frame assemblies using (2) 2-1/4" hex bolts and (2) flat washers to bolt the front rail through the 5 hole gusset plate and use (2) 2" hex bolts, and (2) flat washers for the other rail. **NOTE: SEE DRAWING FOR PERFORATED RAIL TUBE ORIENTATION AND LOCATION.**

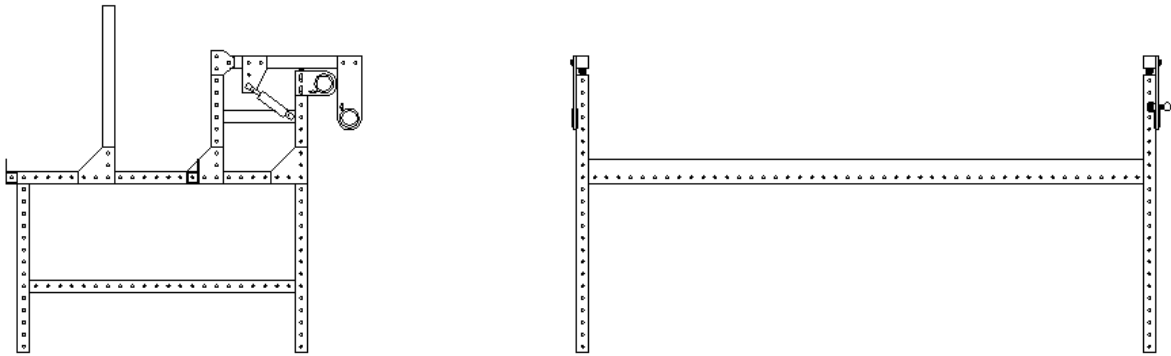

Step 3: Bolt long perforated square tube to side rail support frame assemblies using (2) 3-1/2" hex bolts, (4) flat washers, and (2) nylon insert lock nuts. **NOTE: POSITION TUBE DIRECTLY BELOW FRONT LONG PERFORATED RAIL TUBE.**

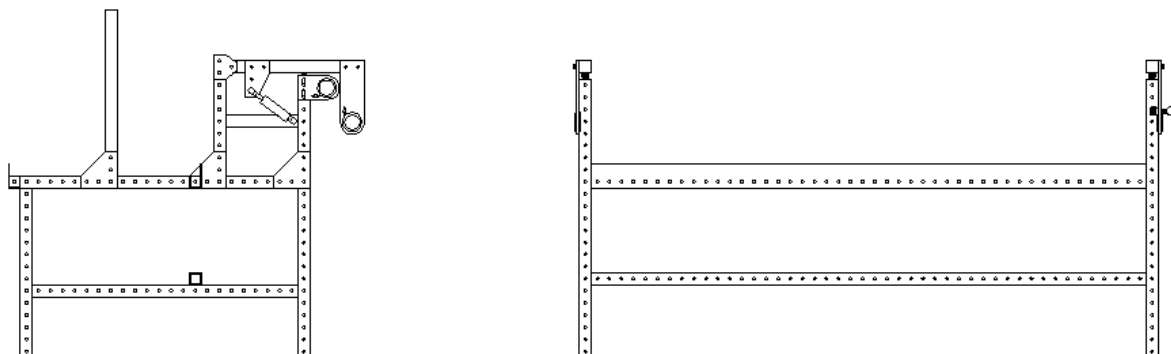

Step 4: Install (1) standard cross block (2 total) into each end of the 18" tube using (1) 2-1/4" hex bolt, (2) flat washer (one per side) and (1) nylon insert lock nut. **NOTE: INSTALL SO THAT HEX HEADS ARE FACING THE SAME DIRECTION ON EACH END.**

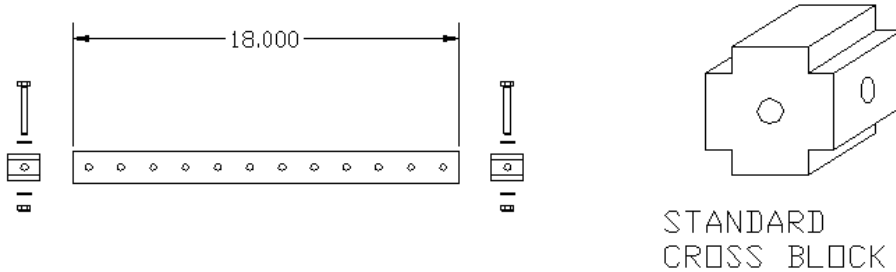

Step 5: Install 18" tube into 6th hole from the bottom of the (2) 22.5" tubes. Use (2) 2" hex bolts and (2) flat washers. The center leg assembly is now complete.

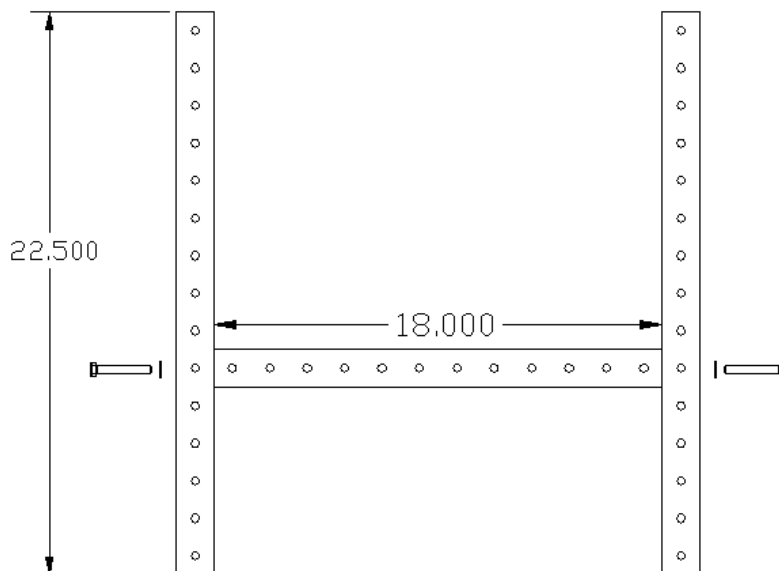

Step 6: Install the center leg assembly at approximately the center of the perforated rail. Use (1) 3-1/2" hex bolts, (2) flat washers, and (1) nylon insert lock nut to attach the assembly to the lower beam. Use (1) 3-1/2" hex bolts, (2) flat washers and (1) nylon insert lock nut to attach the leg assembly to each of the long perforated rails.

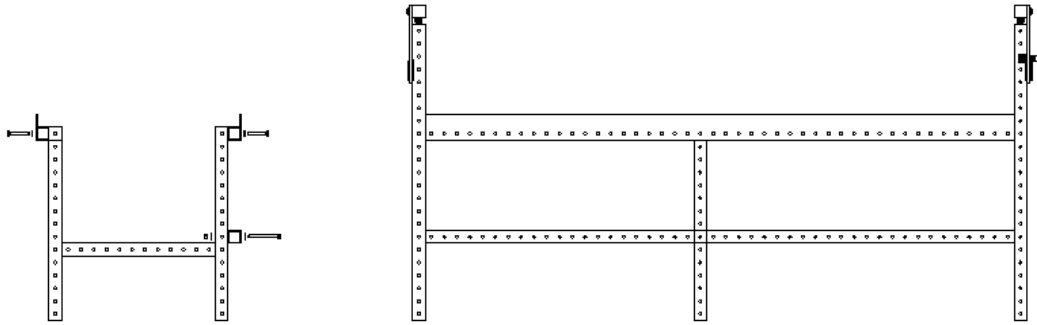

Step 7: Install (2) 20.875" round bar rail spacers with (1) 1/8" thick steel shim on each bar between the long perforated rails 9 holes from either end. Use (2) 2" hex bolts and (2) flat washers per spacer. Try to evenly space the remaining (3) round bar rail spacers down the length of the perforated rails. Start with one bar in the approximate center. Use the remaining two bars to split the difference between the center bar and the bars at the ends. **NOTE: DO NOT OVERTIGHTEN THE BOLTS AS THIS WILL CAUSE DISTORTION OF THE PERFORATED RAIL AND REDUCE STRAIGHTNESS.**

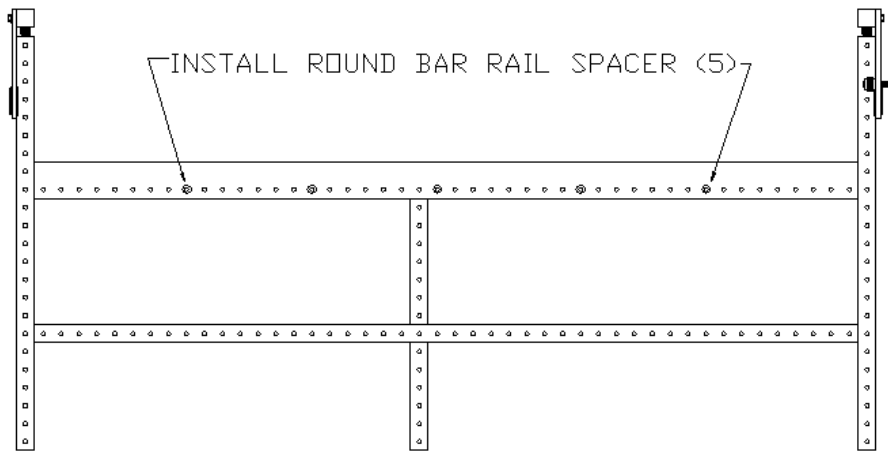

Step 8: Install (4) steel straps to lower tube and upper perforated rail tube using (6) 2-1/4" hex bolts, (12) flat washers, and (6) nylon insert lock nuts. See drawing for hole locations.

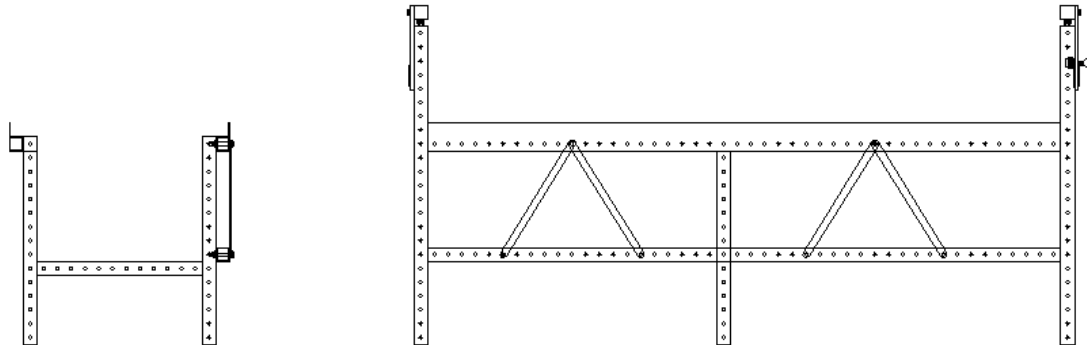

Step 9: Square lower carriage assembly to rail tubes. Insure that rails ride in the center of the wheels for smoothest performance. If rail to wheel relationship is consistent down the entire length of rail, adjust the lower carriage front wheel assembly. If the rail to wheel relationship differs as the carriage moves down the rail, adjust the long rail tubes by adding or removing washers to the round bar rail spacers.

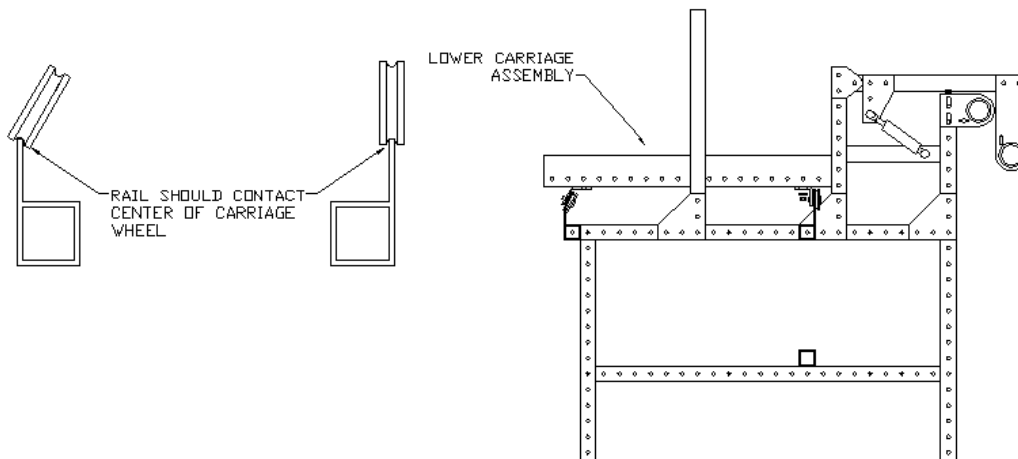

Step 10: Install (2) steel straps onto the long perforated rail tubes using (2) 2-1/4" hex bolts, (4) flat washers and (2) nylon insert lock nuts. See illustration for proper location and orientation.

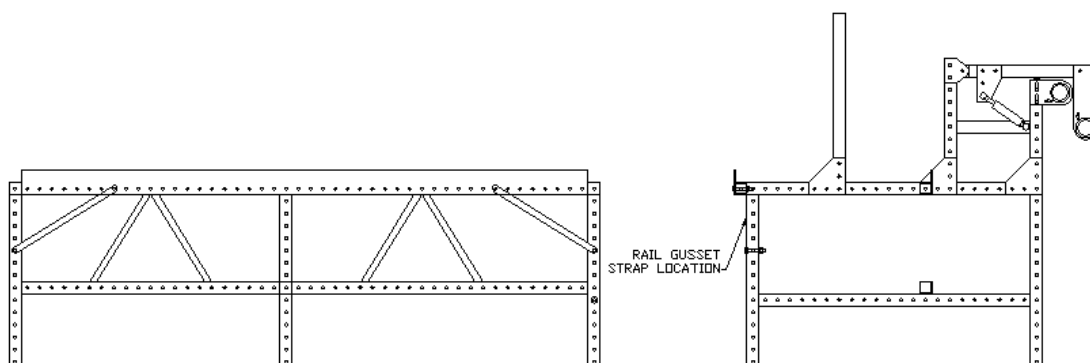

NOTE: IF YOUR INNOVA CAME WITH A CROSS HATCH RULER, INSTALL IT NOW. MARK YOUR PLACE IN THE FRAME ASSEMBLY MANUAL AND GOTO THE CROSS HATCH RULER ASSEMBLY SECTION NOW.

Step 11: Install the take up and bed roller end plates onto the 20.5" vertical slotted beams. Make the take up roller end plate 1-1/2" from the top of the slotted beam and set the bed roller plate at 5-1/2" from the top of the slotted beam. Use (2) 5/16 x 1" hex bolts, (2) lock washers, (2) flat washers, and (1) 5/16 double t-nut per plate. **NOTE: MAKE SURE TO INSTALL THE TAKEUP ROLLER END PLATE WITH GEAR ASSEMBLY ON THE RIGHT SIDE OF THE MACHINE.**

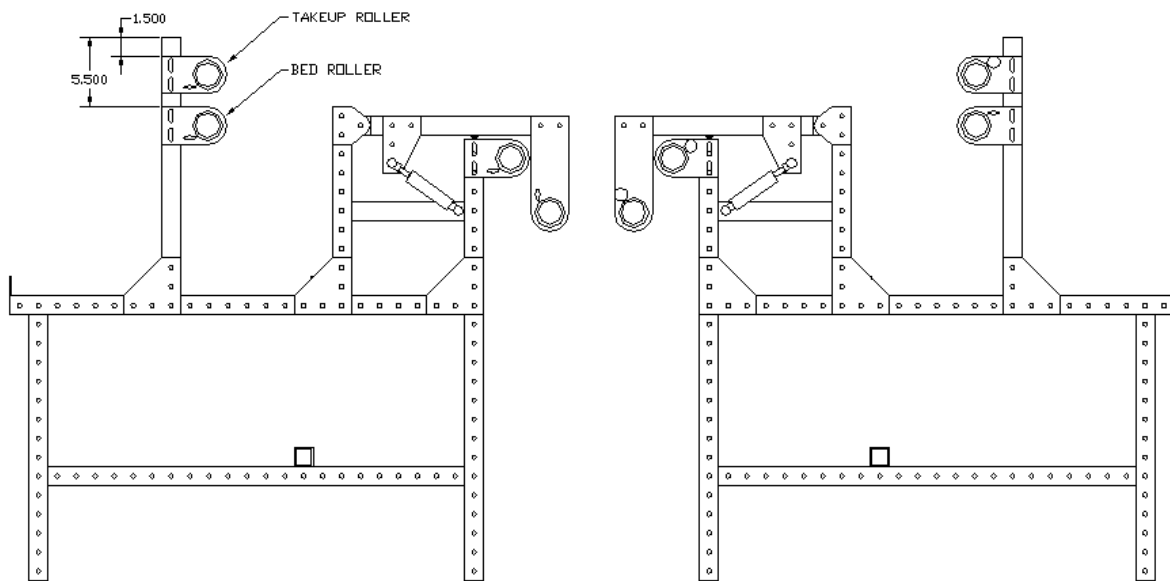

LEFT
SIDE

RIGHT
SIDE

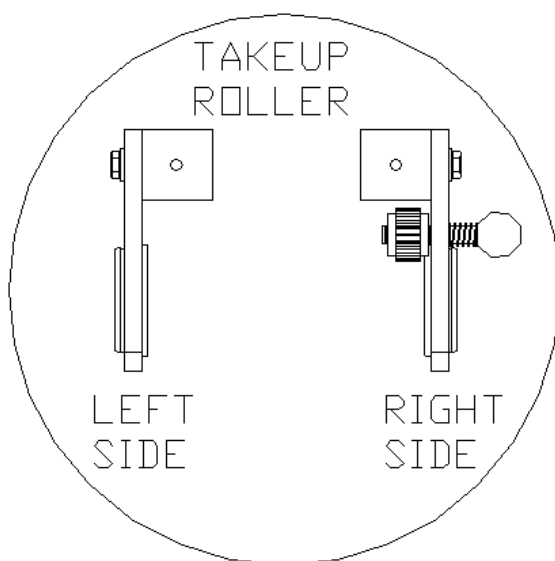

TAKEUP
ROLLER

LEFT
SIDE

RIGHT
SIDE

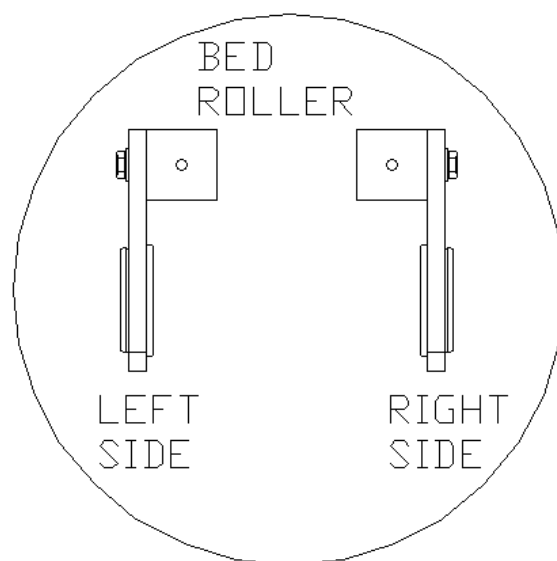

BED
ROLLER

LEFT
SIDE

RIGHT
SIDE

Step 12: Wipe down all (4) roller tubes with a cloth and some mild detergent to remove all oil films, dirt and grit. Dry the roller tubes thoroughly.

Step 13: Install the (3) roller gears, hub first, 1-1/4" off the right end of (3) roller tubes. Tighten all (3) set screws on each gear equally. **NOTE: WHEN INSTALLING THE GEARS, MAKE SURE THE (3) SET SCREWS OF EACH GEAR ARE NOT POKING OUT ON THE INSIDE. THIS WILL MAKE INSTALLATION IMPOSSIBLE. THE GEAR INNER DIAMETER IS A CLOSE FIT TO THE TUBES. THE TUBES HAVE BEEN CHECKED AND DEBURRED TO INSURE THAT THE GEAR FITS PROPERLY. DO NOT HAMMER THE GEAR ONTO THE ROLLER END. IF ALL ELSE FAILS TURN THE ROLLER AROUND AND TRY THE OTHER END.**

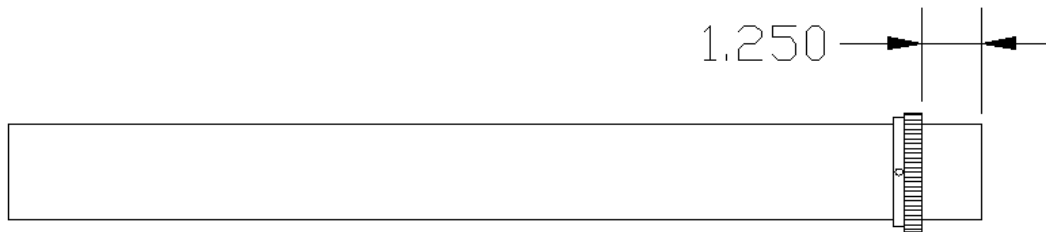

Step 14: Install the (3) roller tubes with gears into the roller end plates with gear assemblies and make sure the gears on the rollers are facing the end plates with the gear assemblies. Install a roller collar onto the roller tube end and tighten the (3) set screws on the collar. **NOTE: MAKE SURE TO LEAVE A SMALL GAP BETWEEN THE COLLAR AND THE PLASTIC BUSHING. THIS WILL HELP MAKE SURE THE ROLLER TURNS SMOOTHLY. CHECK ALL (3) ROLLERS TO INSURE THEY TURN SMOOTHLY. THEY SHOULD ONLY TURN ONE WAY WHEN THE SMALL GEAR ENGAGES THE LARGE ROLLER GEAR.**

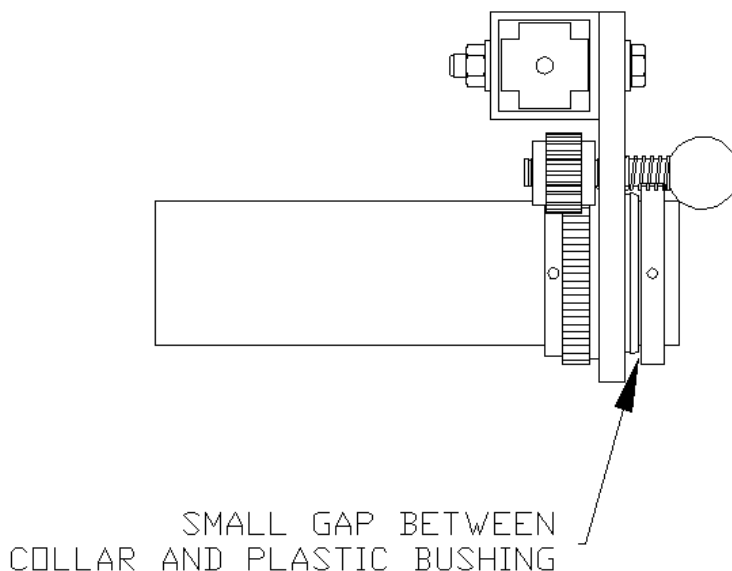

Step 15: Install the remaining roller tube into the bed roller end plates and install the (2) collars, one on either side of the plate, as shown below. Tighten the (3) set screws on each of the collars. Check to make sure the roller turns freely.

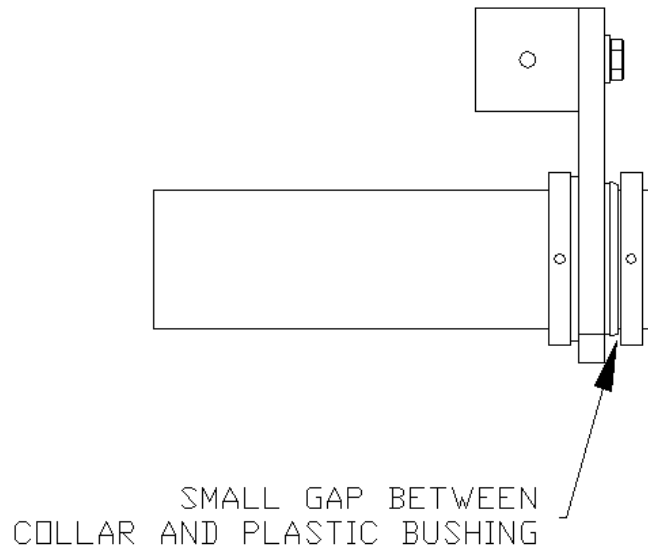

Step 16: Install rubber tape onto the bottom and sides of the long perforated rail tubes. Keep rubber tape away from edge of rail where wheel rides. If the wheel contacts the rubber tape, poor rolling performance may result.

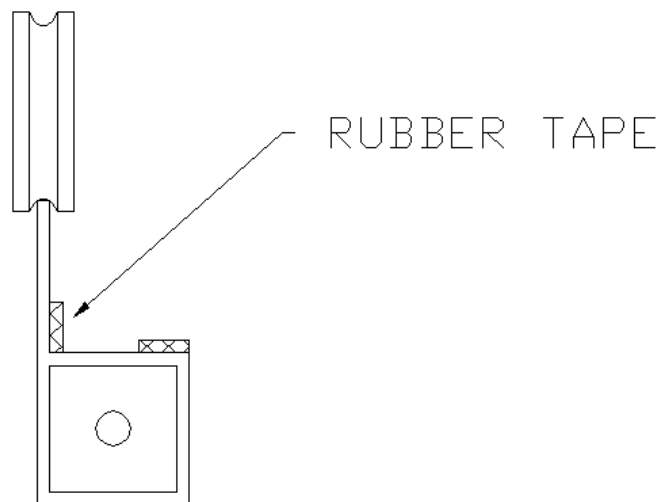

Step 17: Install machine leg assemblies onto frame. Use (2) 3-1/2" hex bolts, (4) flat washers and (2) nylon insert lock nuts per assembly.

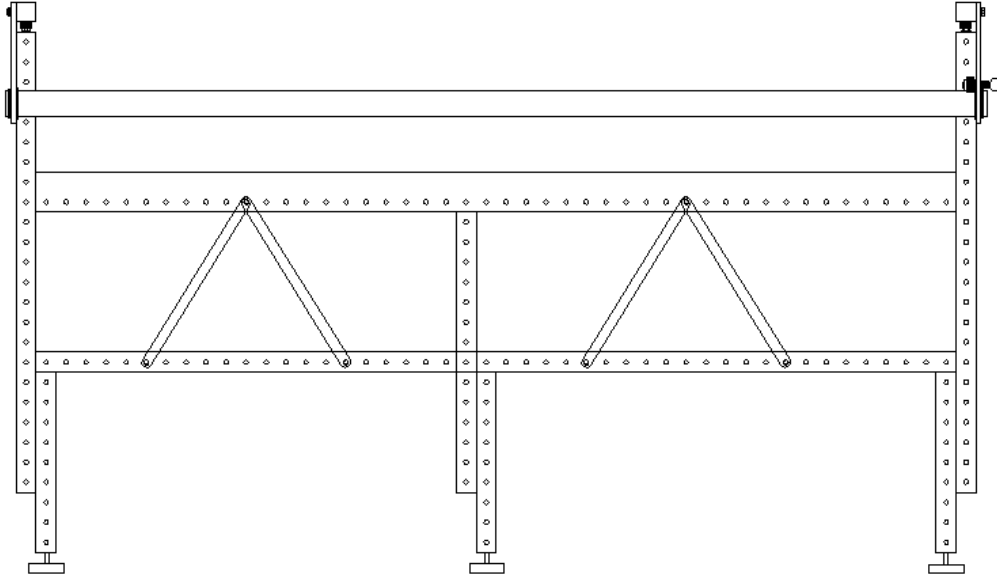

Step 18: Install table top between the long perforated rail tubes. Table should fit smoothly. Table should not be forced in between rails or damage may occur.

Step 19: Install the sewing machine onto lower carriage assembly.

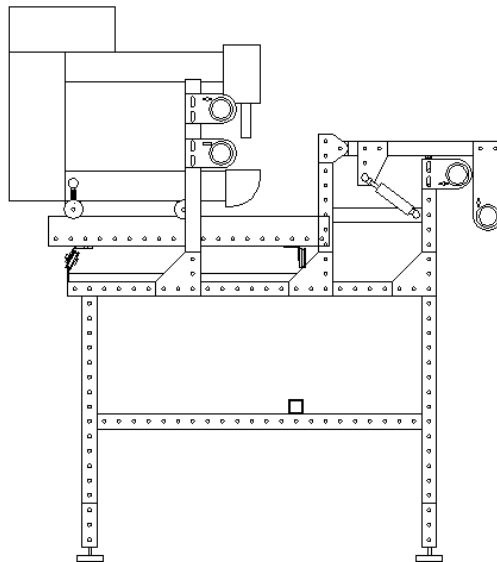

Step 20: Install large rubber bumpers onto 20.5" slotted beam on side of beam facing carriage assembly. Use (1) #10 x 3/4 socket head cap screw and (1) #10 t-nut. Adjust position of bumper so carriage contacts the bumper before hitting the end of frame. Install one bumper on each end.

Step 21: Install the plastic clamp and elastic cord onto each end using the elastic cord clip to adjust the cord length.

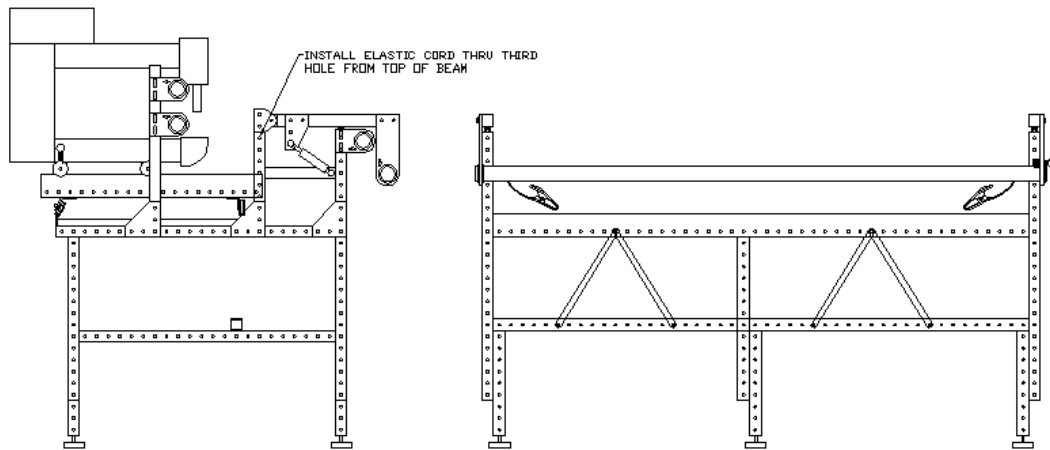

Step 22: Install the remaining (12) tubing end caps into any open square ends of the frame.

Step 23: Install the (4) beam end covers into the ends of the 15-3/4" and 20-1/2" slotted beams.

Step 24: Install the (8) roller end caps into the ends of the roller tubes.

18" Pro-frame axis locks -

(2) Red knob

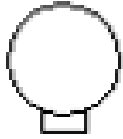

(2) Swivel base



(1) 5/16 Flat washer

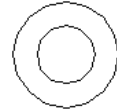

(2) 3-1/2" Threaded stud



(2) Coil Spring



Step 1: Screw a threaded stud through either the left or right side threaded hole on the lower carriage rear wheel assembly.

Step 2: Install (1) swivel base onto the bottom of the threaded stud.

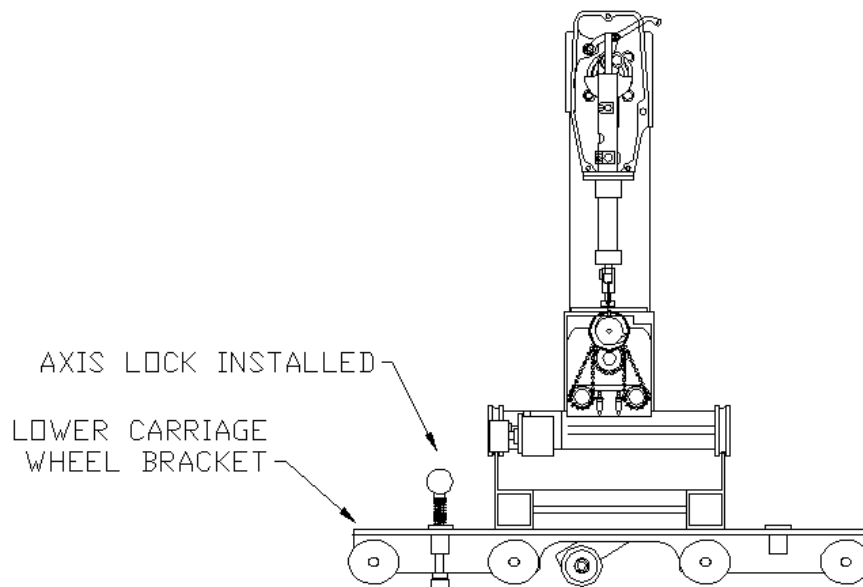

Step 3: Install a coil spring onto the top of the threaded stud of the lower carriage rear wheel assembly.

Step 4: Install a red knob onto the threaded stud.

Step 5: Screw the remaining threaded stud through the threaded hole located on the right side of the aluminum wheel beam of the Innova. You may use either the front or rear wheel beam.

Step 6: Install (1) swivel base onto the bottom of the threaded stud.

Step 7: Install a flat washer onto the top side of the threaded stud in the aluminum wheel beam and then install the coil spring onto the stud.

Step 8: Install the remaining red knob onto the threaded stud.

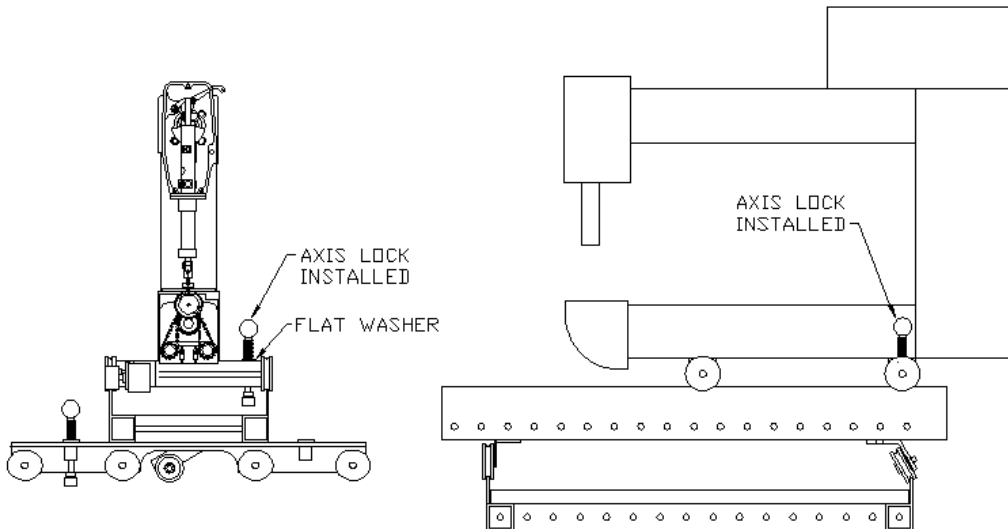

Operational instructions:

Screwing the lower axis lock down until the swivel base makes contact with the table top makes the machine resist rolling left or right.

Screwing the upper axis lock down until the swivel base contacts the lower carriage makes the machine resist rolling forward or back

**ONLY IF EQUIPPED:
18" Pro-frame stitch regulator installation –**

OPTIONAL – Please skip this section if the machine was purchased without stitch regulation.

The machine uses (2) wheel encoders, see figure below, to track the motion of the machine when stitch regulation is active. For shipping purposes, the encoders are wired into the machine but not attached to the sewing head or the lower carriage. Follow the steps below to properly install the stitch regulator.

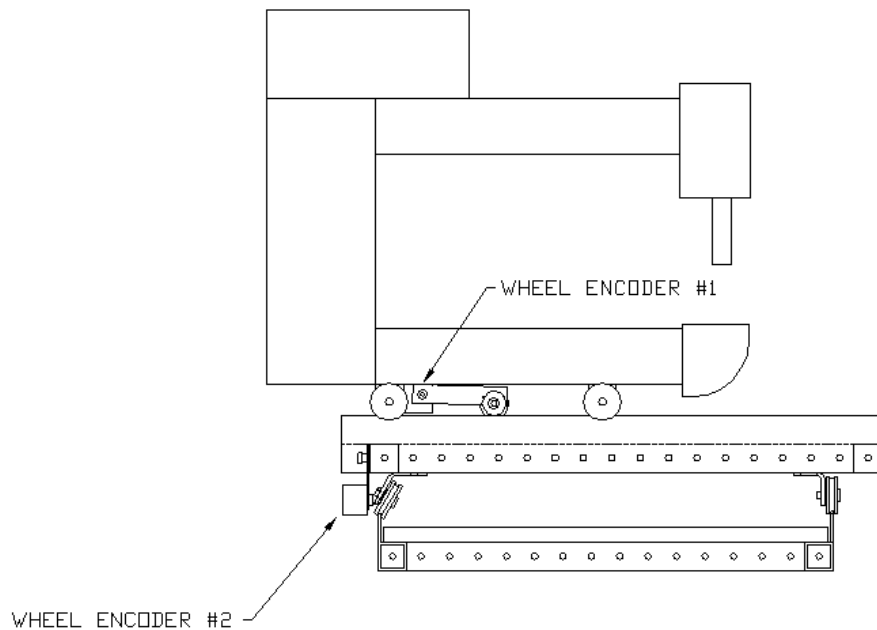

The wheel encoders were designed to be installed in specific locations. The picture below shows the encoders as they are found wired to the sewing head.

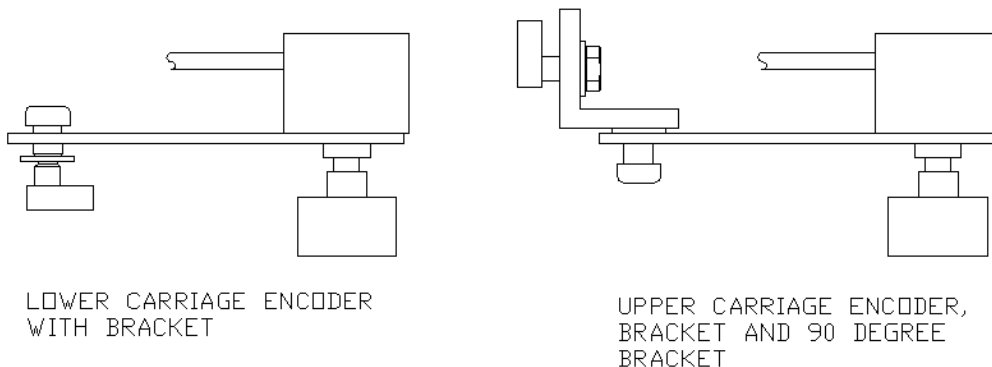

Step 1: Install the upper carriage wheel encoder and 90 degree bracket onto the rear aluminum wheel beam of the sewing head with the supplied bolt and nut. **NOTE: REMOVAL OF THE REAR WHEEL MAY BE NECESSARY TO INSTALL THE NUT.**

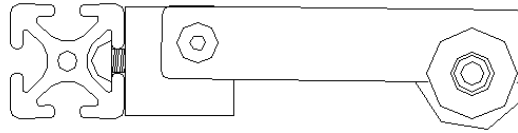
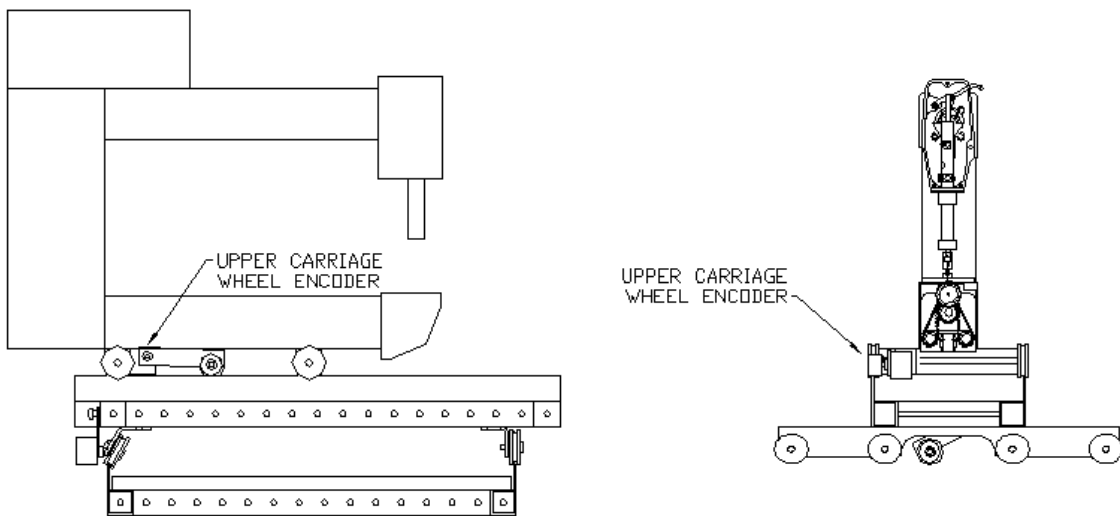

Figure above: Close up view of encoder installed in rear aluminum wheel beam.



Step 2: Install the lower carriage wheel encoder onto the rear slotted beam of the lower carriage with the supplied bolt and nut. **NOTE: REMOVAL OF THE BEAM MAY BE NECESSARY TO INSTALL THE NUT.**

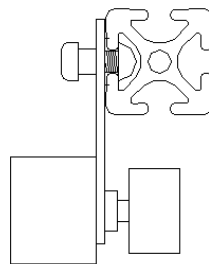
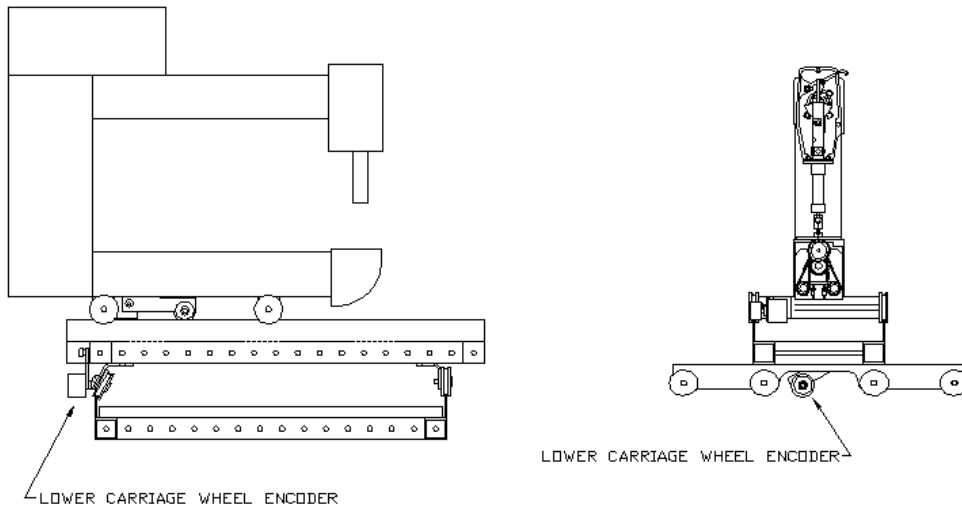

Figure above: Close up view of lower carriage wheel installed on beam.



Step 3: Confirm that the upper and lower wheels ride on the same flange that the plastic wheels of the sewing machine and lower carriage roll on.

Step 4: Confirm that the electrical cable of the lower carriage encoder has enough slack to allow sufficient movement front to back without getting stretched. Install the 1/4 turn wire mount into the top channel of the lower carriage rear beam and nylon tie the main power and lower encoder cable to it. **NOTE: BE SURE TO LEAVE ENOUGH SLACK ON THE ENCODER CABLE WHEN NYLON TYING SO THAT THE ENCODER WHEEL MAKES PROPER CONTACT WITH THE FLANGE. IF THE CABLE IS TOO TIGHT, THE ENCODER WHEEL WILL NOT ROLL PROPERLY CAUSING STITCH REGULATION PROBLEMS.**

