

**ABM International, Inc.**  
Autopilot Assembly Manual

**1.0: Parts List**

Computer (Qty. 1)

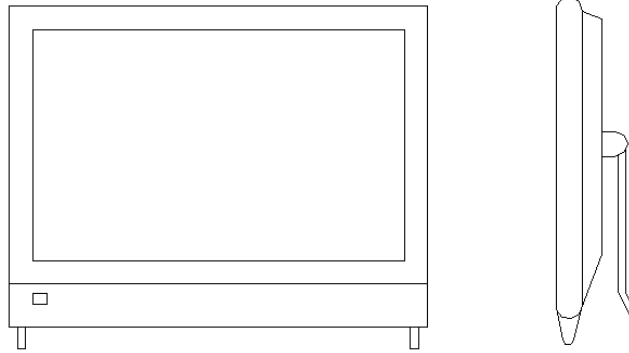

Screen mount (Qty. 1)

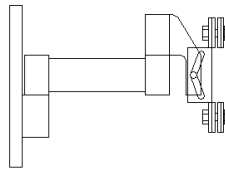

Control Box (Qty. 1)

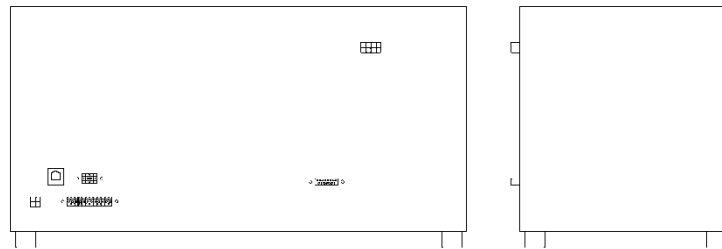

Isolation transformer (Qty. 1)

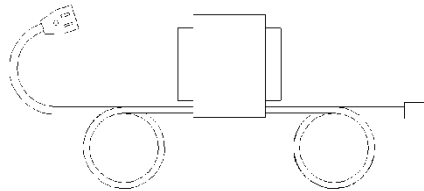

Touch screen beam (Qty. 1)



X-axis Servo Motor (Qty. 1)

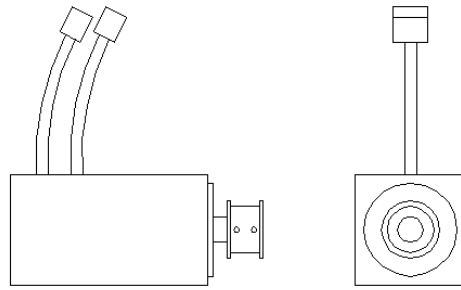

Y-axis Servo Motor (Qty. 1)

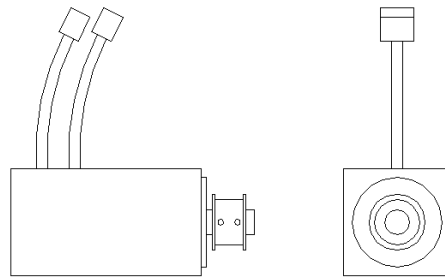

Servo motor encoder cable (Qty. 1)

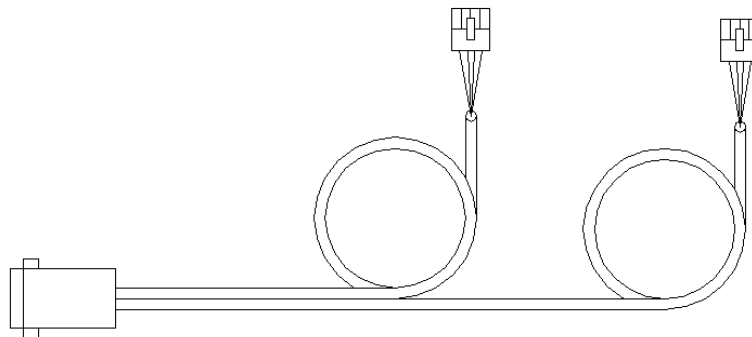

Servo motor power cable (Qty. 1)

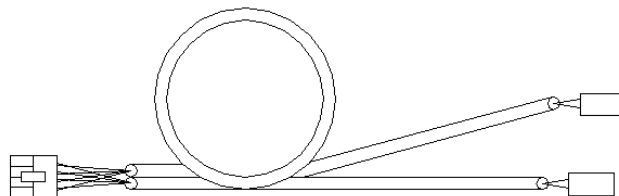

Computer power cord (Qty. 1)

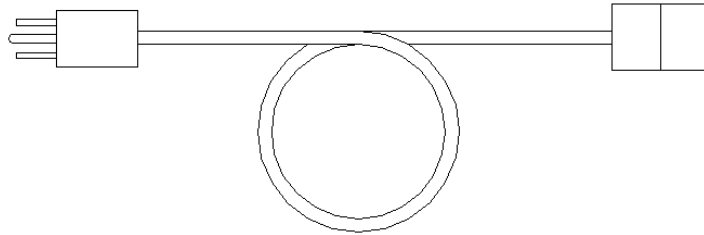

PC to Autopilot communication cable – USB to RJ11 (Qty. 1)

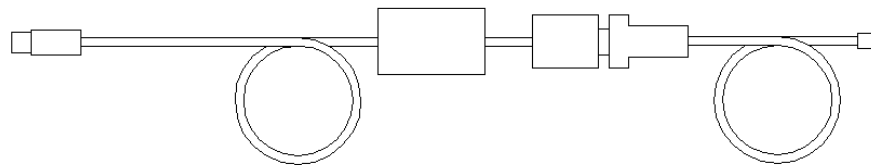

Pushbutton station (Qty. 1)

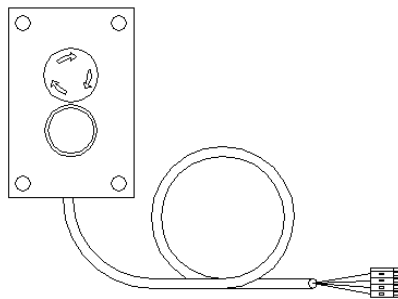

Innova communication cable with terminal block (Qty. 1)

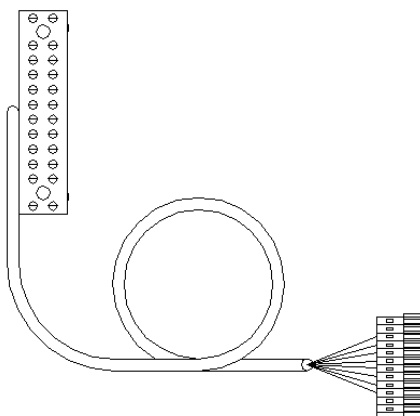

Motor Plate (Qty. 2)

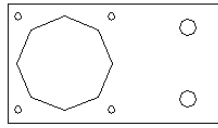

X-axis t-slotted beam (Qty. 1)

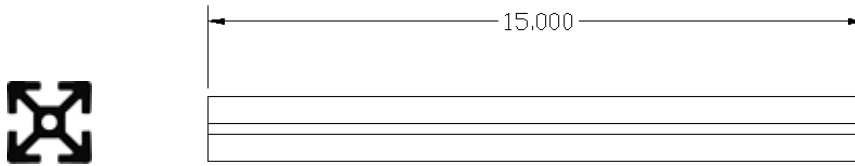

X-axis quick disconnect clamp (Qty. 2)

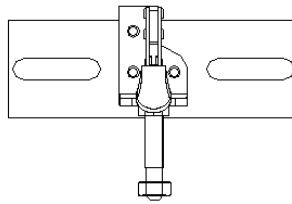

Y-axis quick disconnect clamp (Qty. 1)

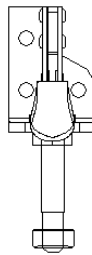

X-axis timing belt clamp plate (Qty. 2)

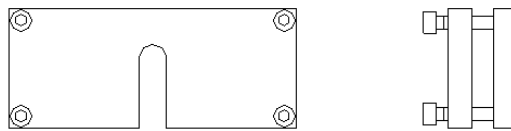

Y-axis timing belt clamp plate (Qty. 1)

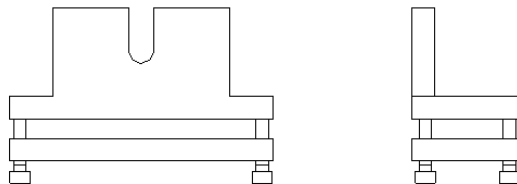

Carriage support cross block and plate (Qty. 1)

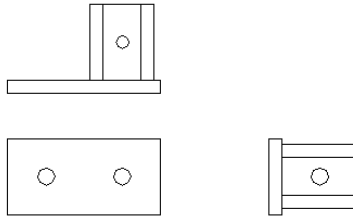

X-axis drive shaft (Qty. 1)

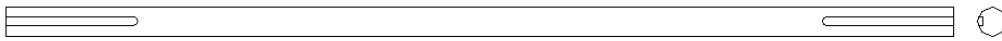

Large drive pulley (Qty. 1)

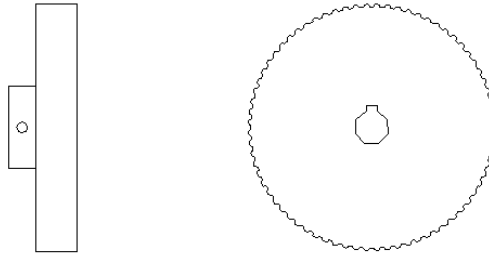

Medium drive pulley (Qty. 2)

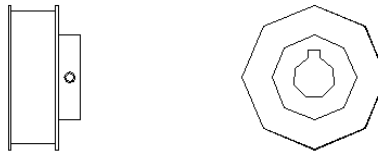

Y-axis drive pulley assembly (Qty. 1)

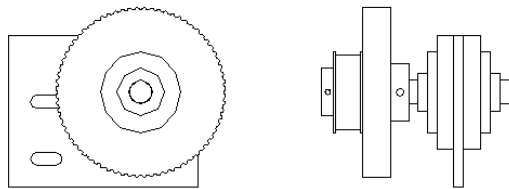

Y-axis idler pulley assembly (Qty. 1)

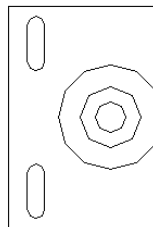

X-axis drive bearing assembly (Qty. 2)

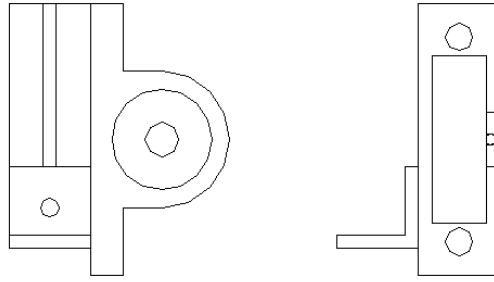

X-axis idler bearing assembly with guard (Qty. 2)

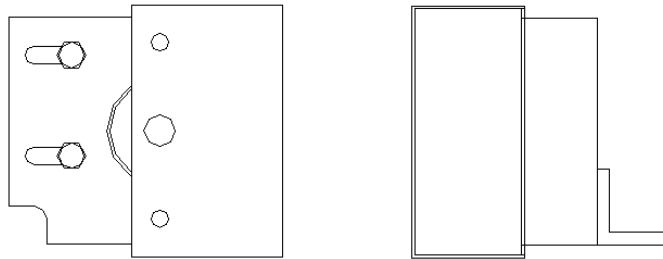

Y-axis motor guard (Qty. 1)

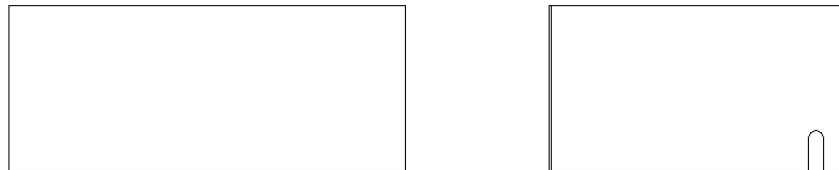

X-axis motor guard (Qty. 1)

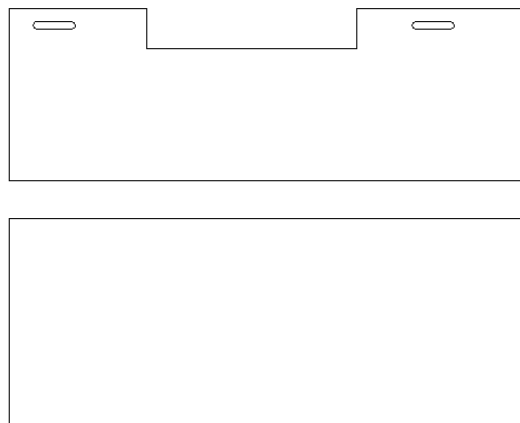

Transformer bracket (Qty. 2)

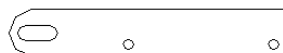

Control box shelf (Qty. 1)



X-axis timing belt (Qty. 2)

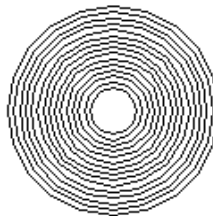

Y-axis timing belt (Qty. 1)

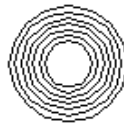

X and Y-axis main timing belt (Qty. 2)

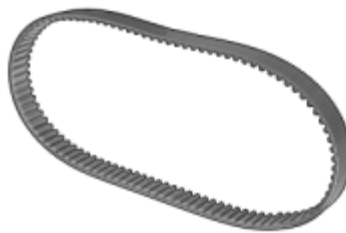

3/16 x 3/16 machine key (Qty. 3)

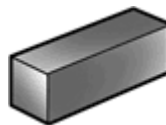

Twist lock cable tie holder (Qty. 2)





## 2.0 X-axis Assembly

**NOTE: The Autopilot assembly manual demonstrates how to install an Autopilot on a 26" Innova. Assembly of an Autopilot on an 18" or 22" Innova will differ slightly in some steps. See Section 6.0 for amendments to installation of an Autopilot for 18" machines.**

Step 1: Install motor plate onto 15" t-slotted beam using (2) 5/16 x 3/4" HEX bolts, (2) flat washers and (2) 5/16 T-nuts. Locate the plate in the center of the beam.

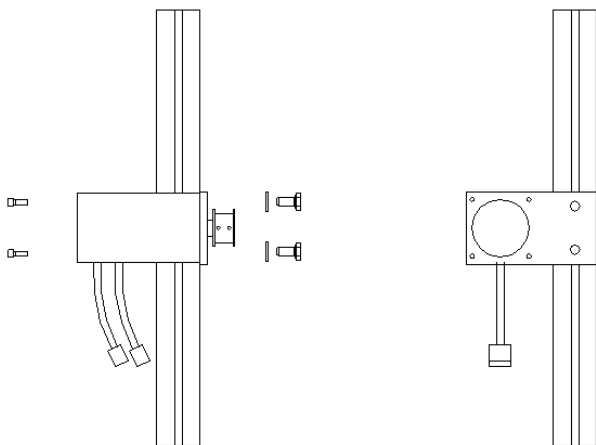

Step 2: Install the X-axis servo motor onto the motor plate using (4) 8-32 x 1/2" socket head cap screws. Install the motor so the wires are positioned facing down like the picture above.

Step 3: Install the 15" X-axis t-slotted beam onto the right side of the frame in the third hole from the rear of the machine. Use (2) 5/16 x 2" HEX bolts, (2) flat washers and (2) 5/16 T-nuts.

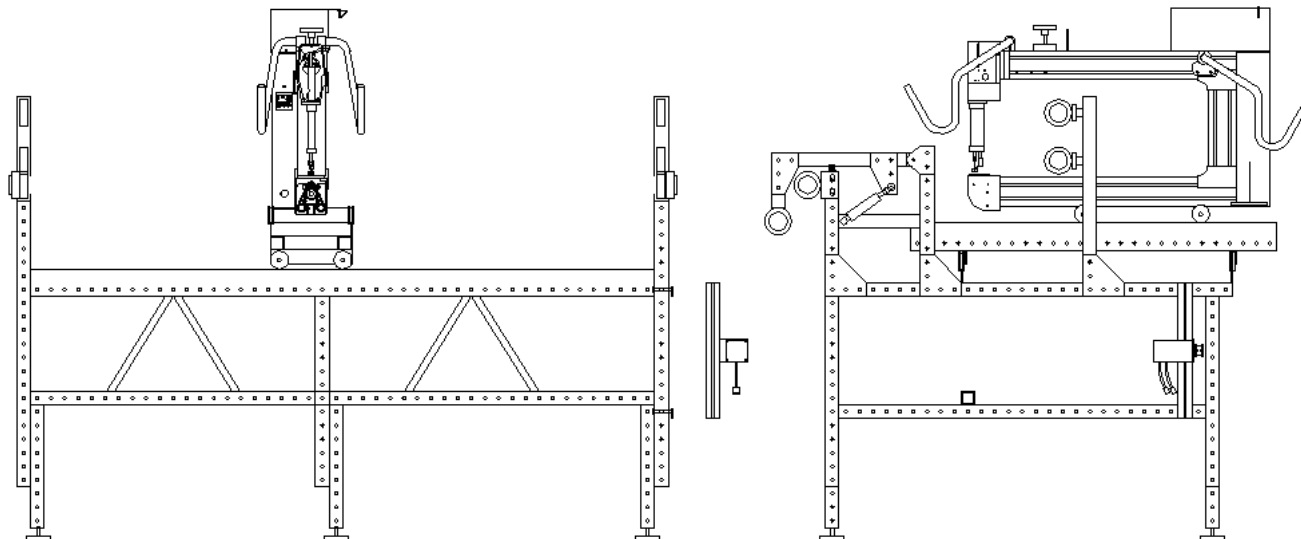

Step 4: **SEE SECTION 6.0 FOR 18" MACHINES.** Assemble (2) X-axis drive bearings assemblies with (2) medium drive pulleys and (1) large drive pulley. Make sure to place a key into the slot of the shaft for each of the pulleys. Leave the pulleys and bearing assemblies loose on the shaft. **DO NOT TIGHTEN THE SET SCREWS.**

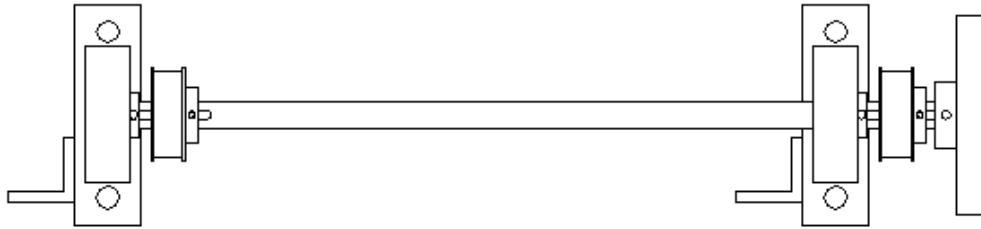

Step 5: **SEE SECTION 6.0 FOR 18" MACHINES.** Install the X-axis drive shaft assembly onto the right side of the frame. Attach the bearing assemblies at the 5<sup>th</sup> and 16<sup>th</sup> hole, from the back of the top side tube. Bolt the bearing assemblies using (2) 5/16 x 2" HEX bolts and (2) flat washers in the 5<sup>th</sup> and 16<sup>th</sup> hole from the bottom up. Additionally, use (2) 5/16 x 2-1/2" HEX bolts, (4) flat washers and (2) nylon insert lock nuts to secure the slotted angle brackets to the tube in the 6<sup>th</sup> and 17<sup>th</sup> hole. NOTE: Install the 2-1/2" bolts with the head of the bolt on the top side of the frame and the nut on the bottom side.

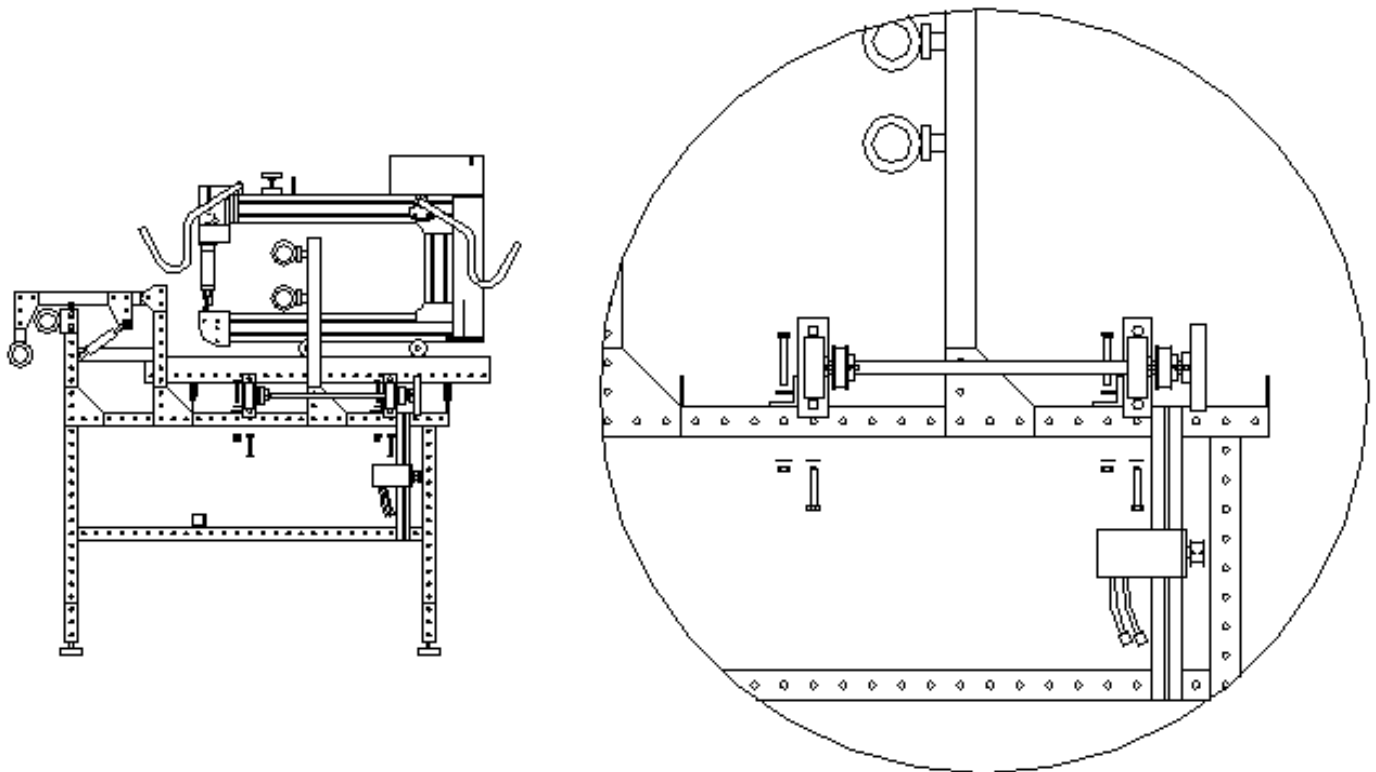

Step 6: **SEE SECTION 6.0 FOR 18" MACHINES.** Install the (2) X-axis idler bearing assemblies with guards into the 5<sup>th</sup> and 16<sup>th</sup> hole from the rear of the left side of the frame. Use (2) 5/16 x 2" HEX bolts and (2) flat washers. Additionally, use (2) 5/16 x 2-1/2" HEX bolts, (4) flat washers and (2) nylon insert lock nuts to secure the slotted angle brackets to the tube in the 6<sup>th</sup> and 17<sup>th</sup> hole. NOTE: Install the 2-1/2" bolts with the head of the bolt on the top side of the frame and the nut on the bottom side.

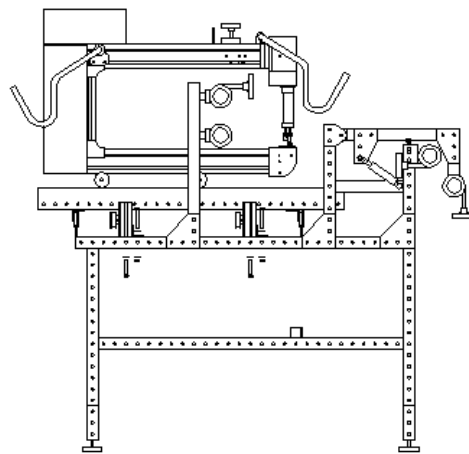
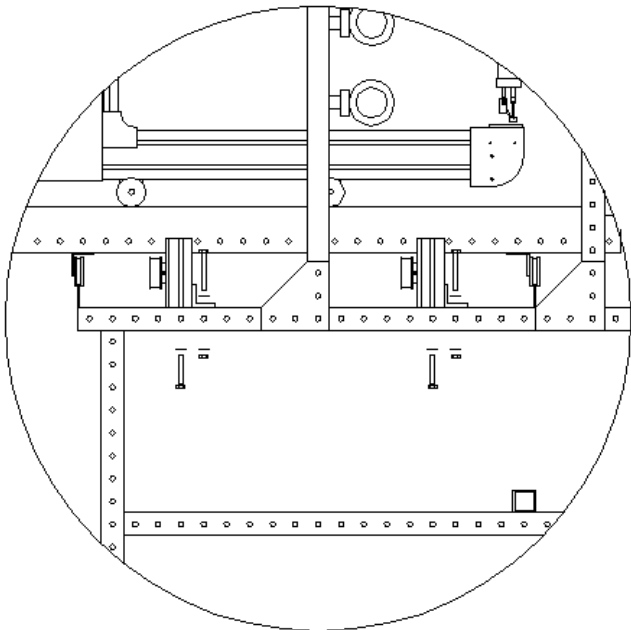

Step 7: Using (4) 5/16 x 2-3/4" HEX bolts, (4) flat washers and (4) nylon insert lock nuts, install the X-axis quick disconnect clamp brackets onto the left side of the lower carriage. Install the brackets so that the red handled clamp is aligned with the center of the idler pulleys on the left side of the machine.

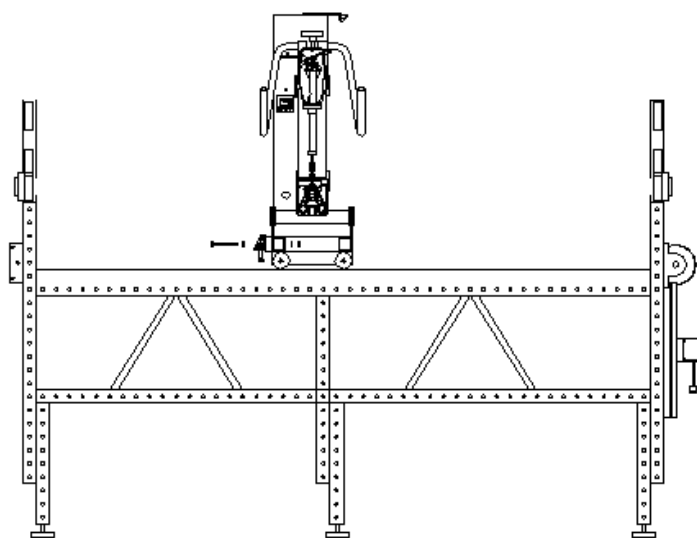
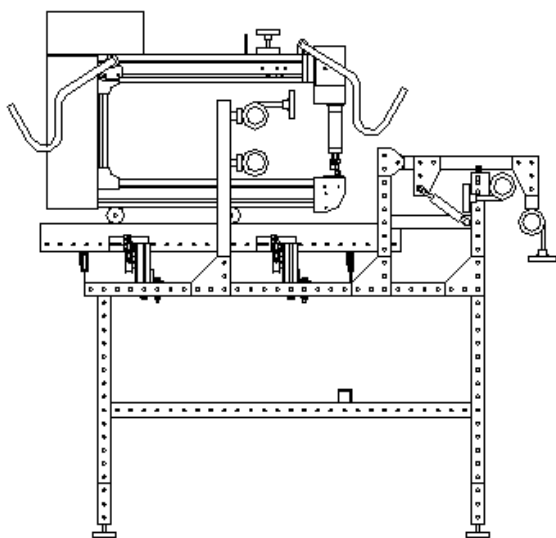

Step 8: Install the X-axis timing belt clamp onto the X-axis quick disconnect clamp. **NOTE: INSTALL THE CLAMP PLATE SO THAT THE SIDE WITH THE SMALL SLOT IS FACING UP.** Lift the red handle and check to make sure the clamp grips the plate assembly firmly. If the plate is loose, use a 7/16 wrench to tighten the hex nut on the bottom end of the clamp. **DO NOT OVERTIGHTEN OR THE CLAMP WILL BEND WHEN YOU ATTEMPT TO LOCK THE PLATE IN PLACE.**

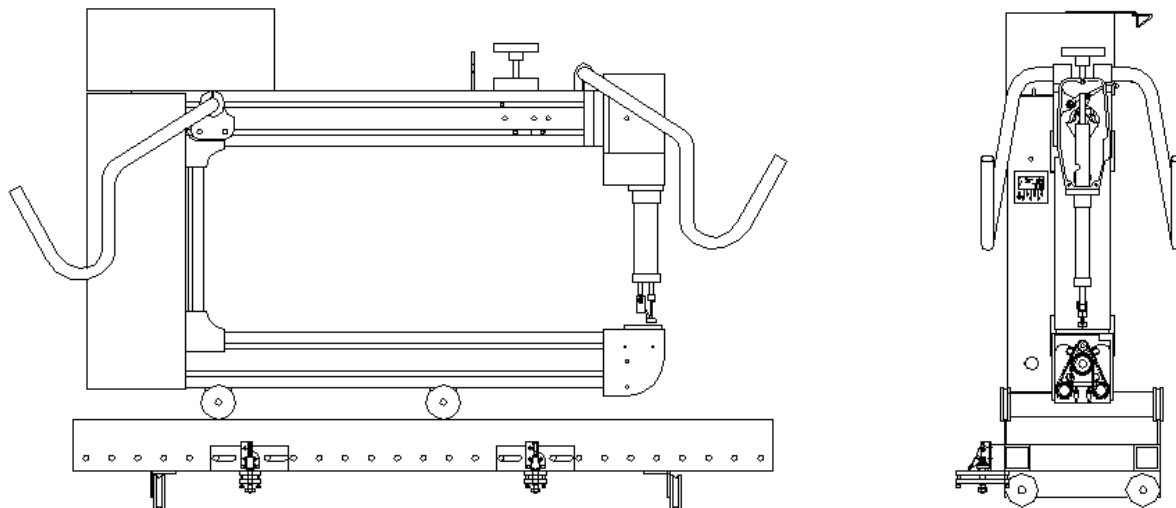

Step 9: Lay the white X-axis timing belts on the frame table with the teeth facing up. On the right side of the frame, pass the timing belt around the medium drive pulleys and secure to the belt clamp plates on the carriage. **NOTE: THE BELT WILL PASS UNDER THE CARRIAGE AND CONNECT TO THE CLAMP PLATES MOUNTED ON THE LEFT SIDE OF CARRIAGE.** Pass the left end of timing belt around the idler pulley assemblies and attach to the timing belt clamp plate. Tighten the timing belt clamp plate bolts and check to make sure that both timing belt clamp plates are equidistant from the left end. Jump the belt over the pulley on the drive end to align the clamp plates.

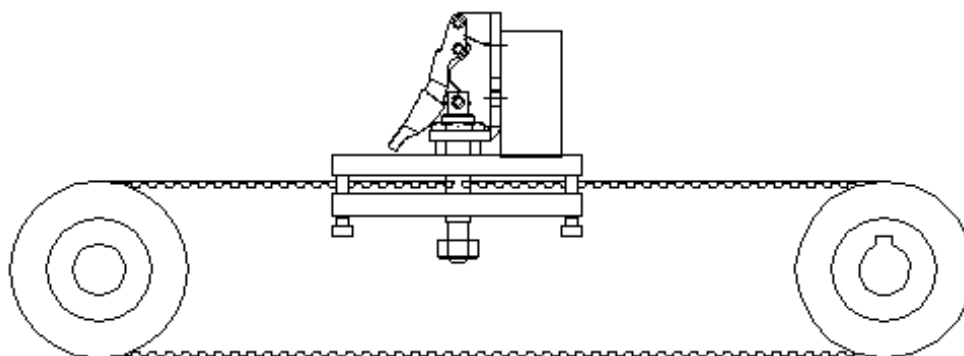

Step 10: Tighten the belts by loosening the (2) 5/16 HEX head bolts on the slotted idler bearing plates and pulling the plates out away from the frame.

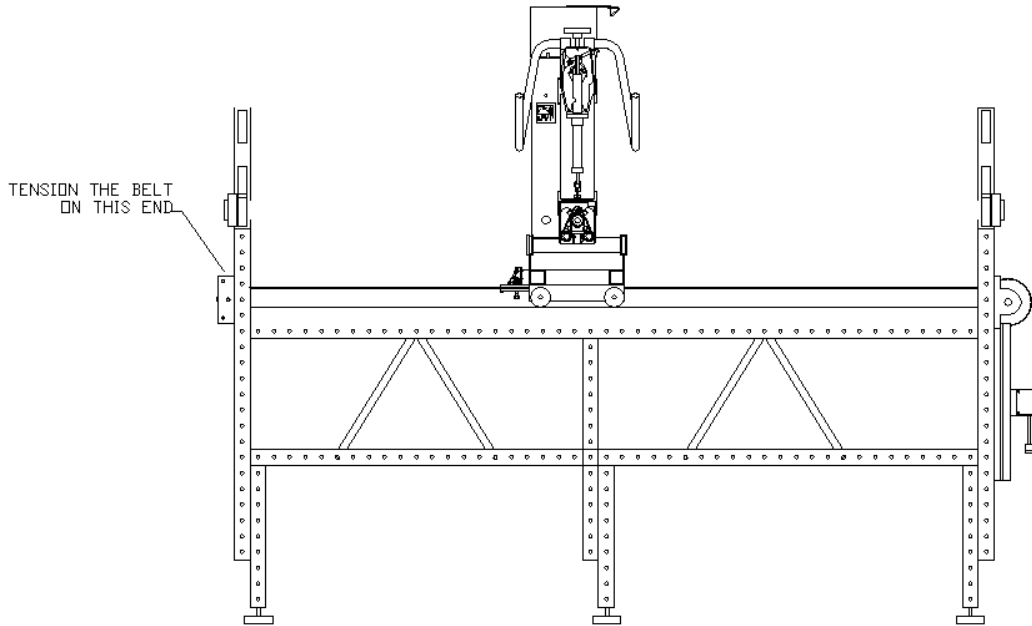

Step 11: Loosen the X-axis motor plate and slide the motor as high as possible on the slotted beam. Install the black X-axis main timing belt onto the motor pulley as well as the large drive pulley. Slide the large pulley on the shaft to align the large pulley and motor pulley. Tighten the set screws on the large pulley. Pull down on the motor plate to tension the black belt and tighten the (2) HEX bolts on the motor plate. **NOTE: THE BELT SHOULD BE TIGHTENED SO THAT RESISTANCE IS FELT WHEN YOU PRESS ON THE UNSUPPORTED SECTION OF THE BELT.**

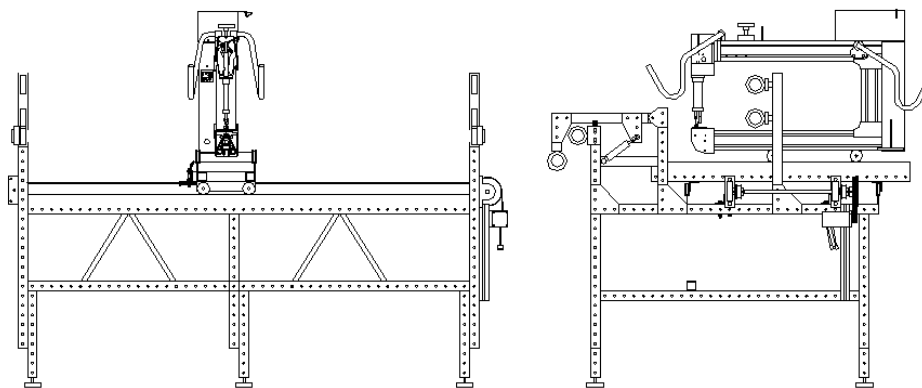

Step 12: Align the medium drive pulleys so the white X-axis timing belt is straight down the length of the frame. Ensure that all of the drive pulleys have keys in the keyways and tighten all (8) set screws, (4) on the medium drive pulleys and (4) on the bearing assemblies.



Step 13: Install the X-axis motor guard onto the right side of the frame. The slots in the top of the guard will align with the tapped holes in the t-slotted beams of the bearing assemblies. Use (2) 5/16 x 3/4" HEX bolts, (2) lock washers, and (2) flat washers to secure the guard.

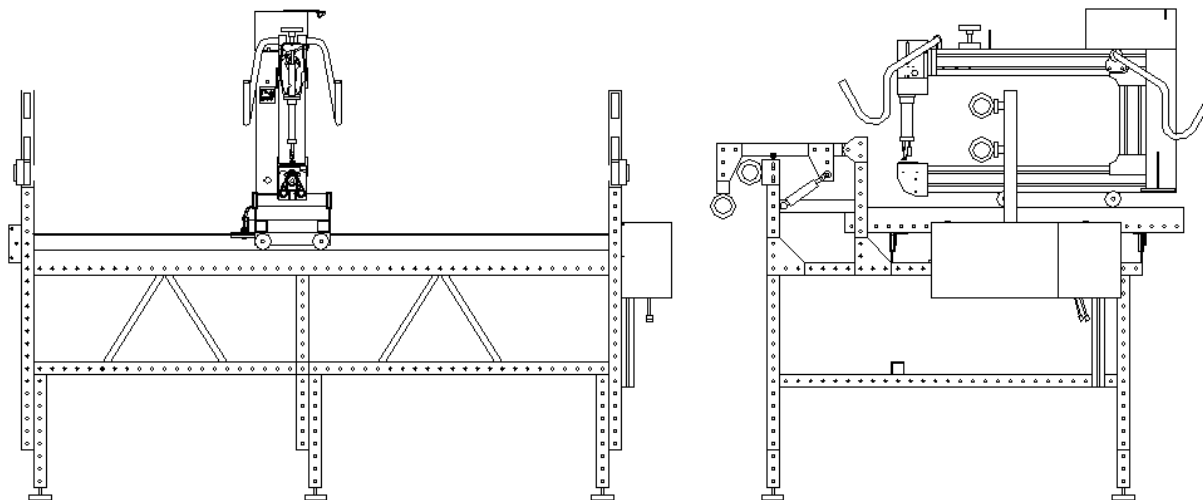

Step 14: If the X-axis idler pulleys did not come with the guards installed, install the guards onto the assemblies using (4) ¼" button head bolts and (4) flat washers.

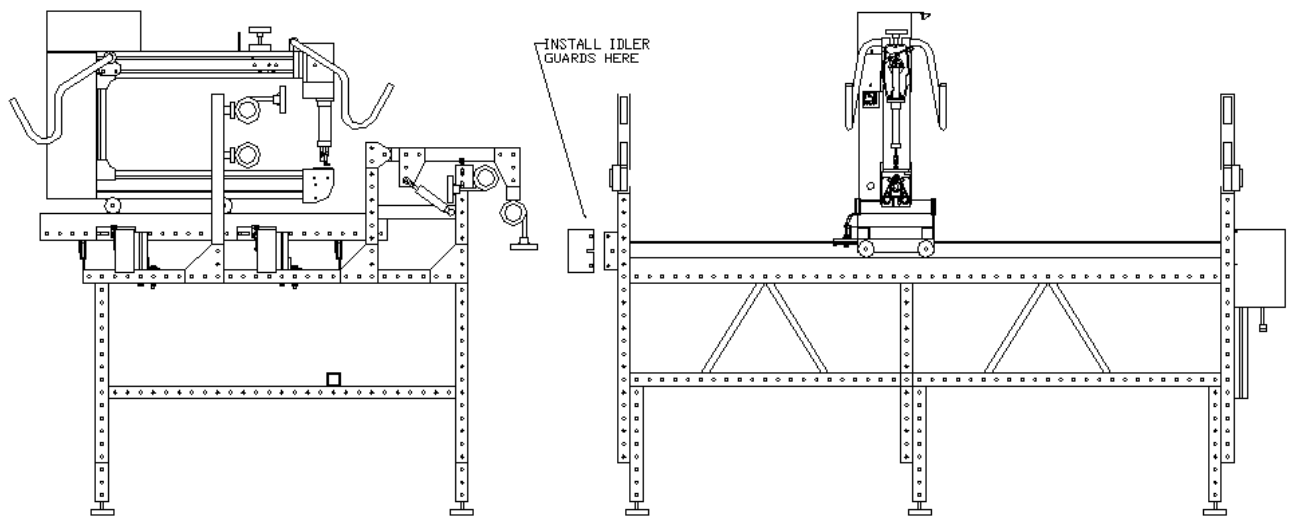

### 3.0 Y-Axis assembly

Step 1: In order to complete the installation of the Y-axis assembly onto an Innova, the front 6" t-slotted beam of the lower carriage must be located at the extreme front of the carriage. If the front beam is not in this position, please relocate it now.

Remove both hex head bolts on the either side of the carriage that hold the front t-slotted beam and remove the beam. Install (2) 5/16 t-nuts in the top of the beam, (1) 5/16 t-nut in the front face of the beam and (2) 5/16 t-nuts in the bottom of the beam. Re-install the beam in the first hole at the front of the carriage. Install the carriage support cross block into the front end of the left carriage rail and pass the original bolt holding the t-slotted beam through it and secure. Using a 5/16 x 3/4" hex head bolt and flat washer attach the cross block plate to the front face of the t-slotted beam. Make sure to tighten both sides of the 6" t-slotted beam to either lower carriage rail.

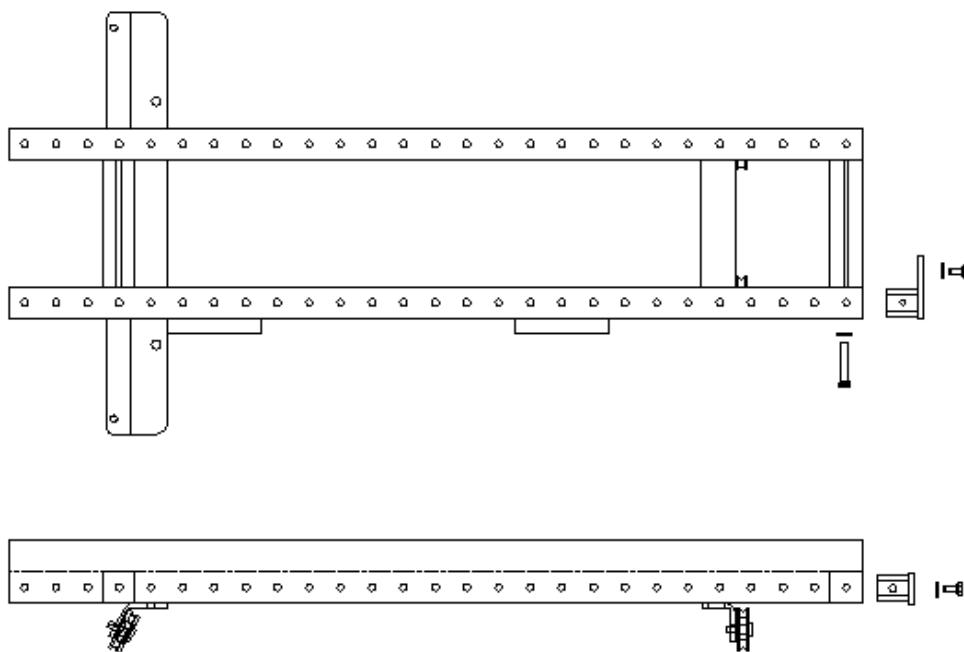



Step 2: Install the Y-axis drive pulley assembly to lower side of the front t-slotted beam using (2) 5/16 x 3/4" hex head bolts and flat washers. Adjust the assembly so the large diameter pulley is flush to outside of the lower carriage right rail. Tighten the bolts.

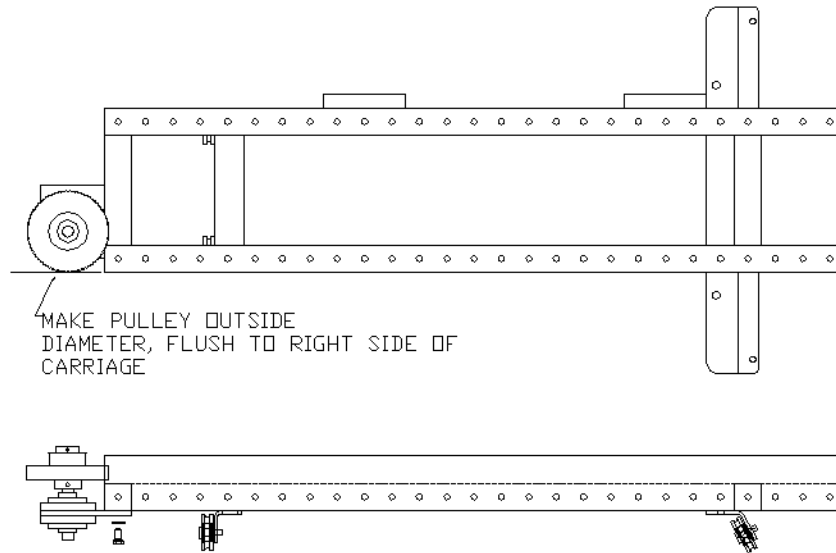

Step 3: Install the Y-axis servo motor onto the motor plate using (4) 8-32 x 1/2" socket head cap screws. Install the motor plate onto the top side of the front t-slotted beam using (2) 5/16 x 3/4" hex head bolts and flat washers.

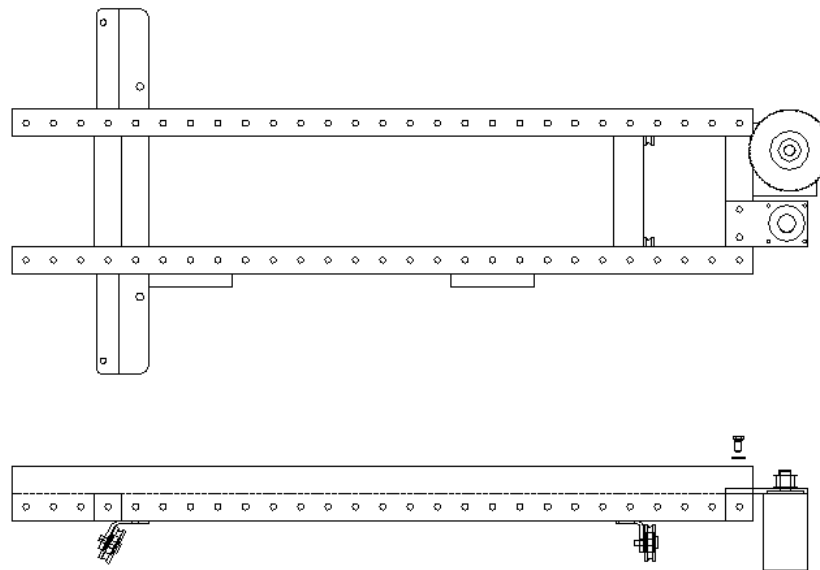

Step 4: Install the black Y-axis main timing belt onto the motor pulley and large drive pulley. Tension the belt by loosening the motor plate screws and pulling the motor away from the large pulley. Tighten the bolts **NOTE: THE BELT SHOULD BE TIGHTENED SO THAT RESISTANCE IS FELT WHEN YOU PRESS ON THE UNSUPPORTED SECTION OF THE BELT.**

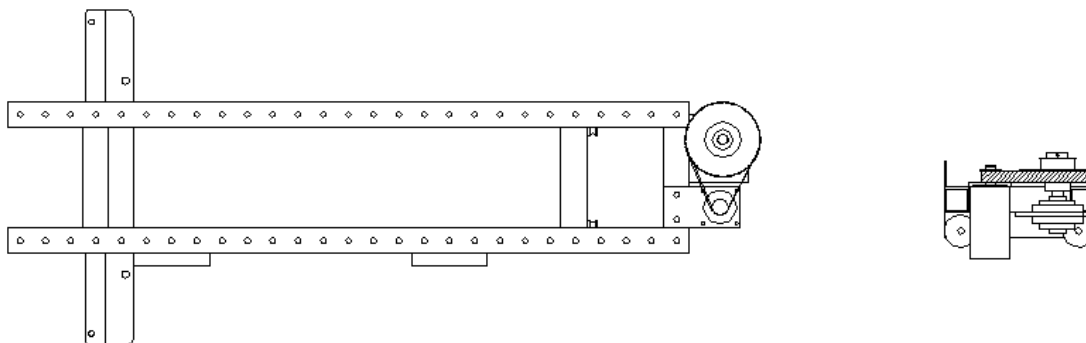

Step 5: Install the Y-axis idler pulley onto the inside of the right carriage rail at the 6<sup>th</sup> hole from the rear using (2) 5/16 x 2-3/4" hex head bolt, (4) flat washers and (2) nylon insert lock nuts.

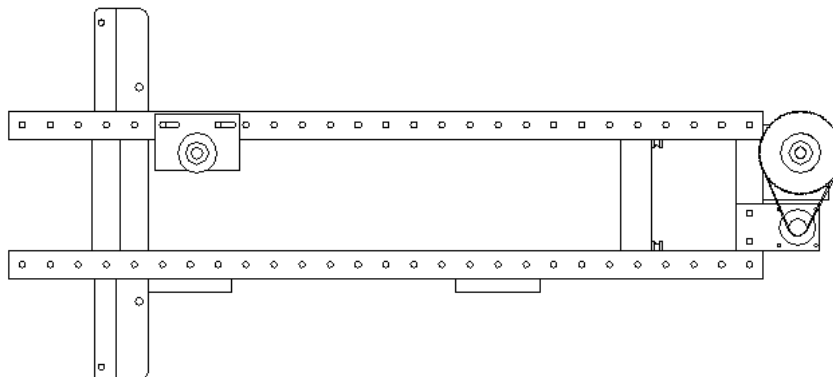

Step 6: Install the Y-axis quick disconnect clamp onto right front wheel beam of the Innova using (2) 8-32 x 1/2" socket head bolts and (2) 8-32 t-nuts. See the diagram below for correct orientation.

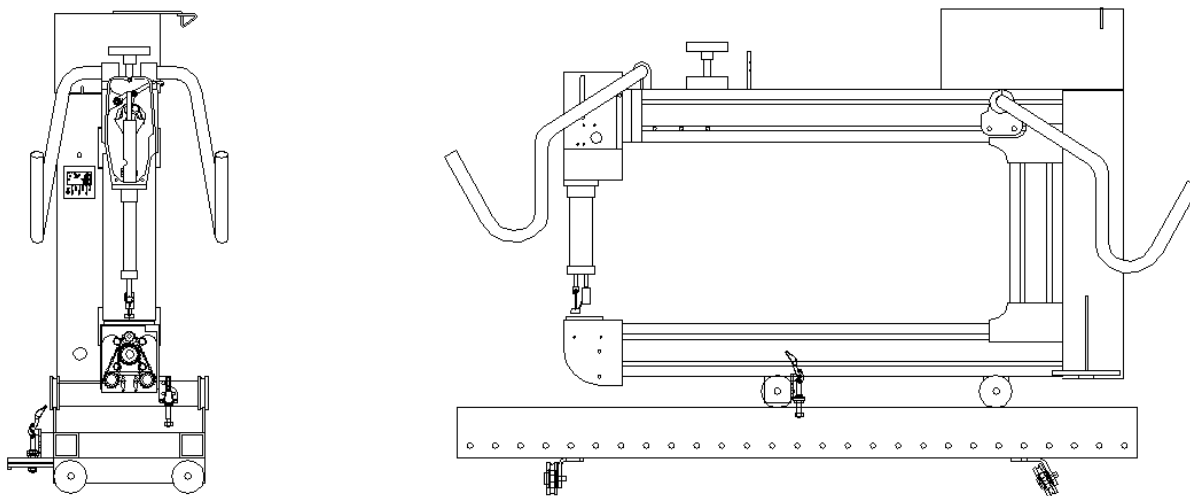

Step 7: Install the Y-axis timing belt clamp plate onto the quick disconnect clamp. Be sure to follow the orientation in the diagram below.

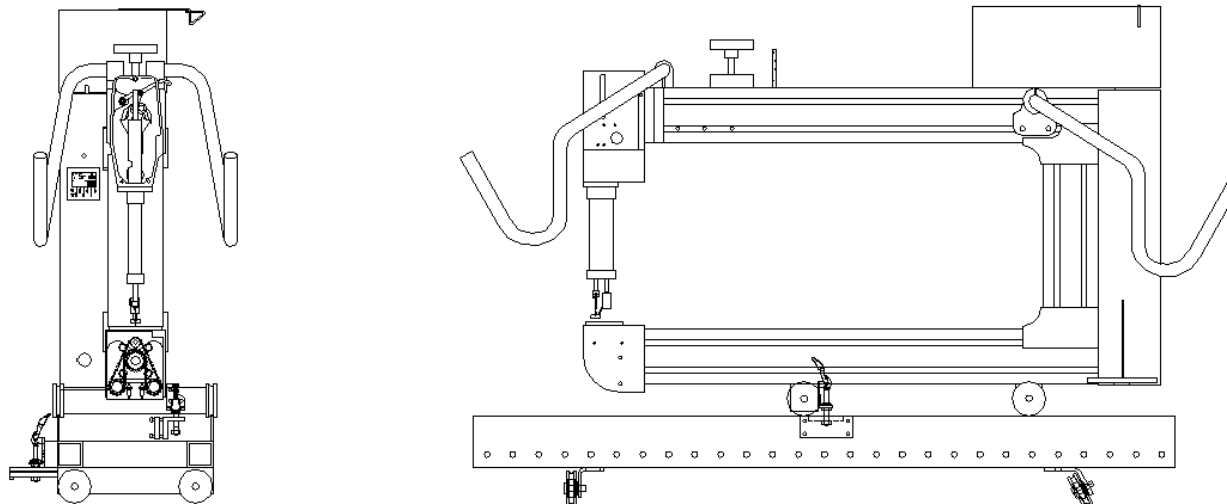

Step 8: Install the white Y-axis timing belt onto the front medium drive pulley and the rear idler pulley. Install the open ends of the belt onto the clamp plate and tighten firmly. **NOTE: THE CLAMP PLATE MUST BE INSTALLED ON THE LEFT SIDE OF THE WHITE TIMING BELT LOOP. TO CHECK FOR PROPER INSTALLATION, THE INNOVA SHOULD MOVE TOWARD THE FRONT WHEN THE LARGE PULLEY IS TURNED COUNTER-CLOCKWISE WHEN VIEWED FACING FROM THE TOP LOOKING DOWN.**

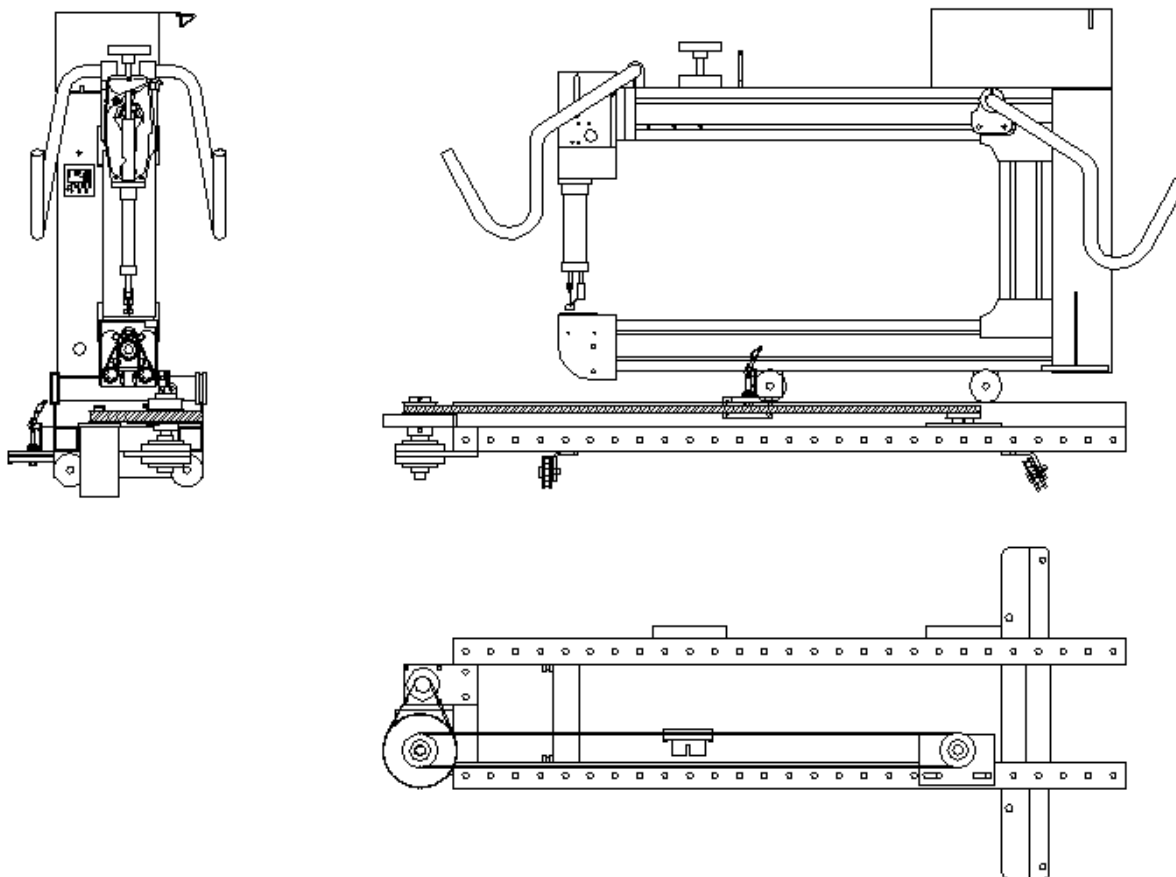

Step 9: Tighten the white belt by pulling the idler pulley assembly toward the rear of the carriage and tightening the (2) hex head bolts.

Step 10: Install the Y-axis motor guard onto the front of the lower carriage.

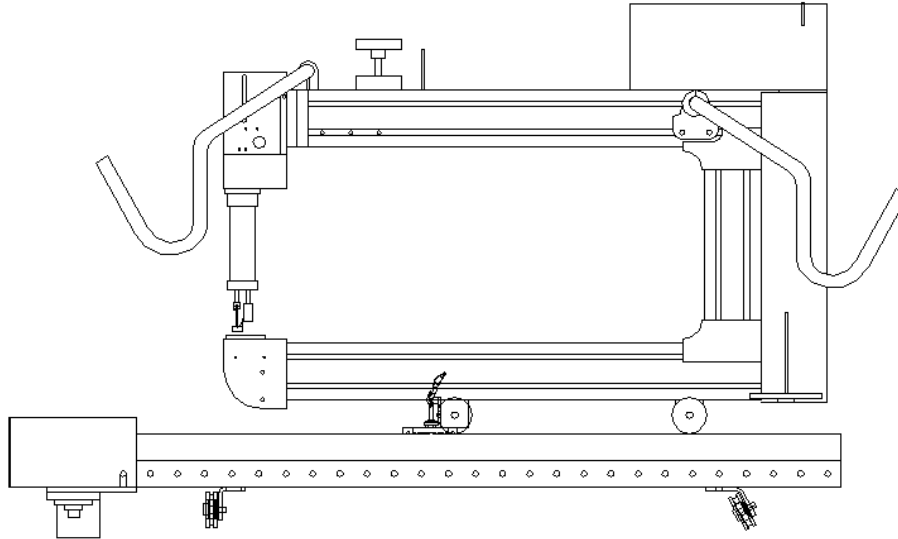

#### 4.0 Wiring

Step 1: Loosen, but do not remove, the (8) screws on the top motor cover and the (7) screws on the rear electronics cover of the Innova. Remove the top motor and rear cover and set aside. Take care not to scratch the covers.

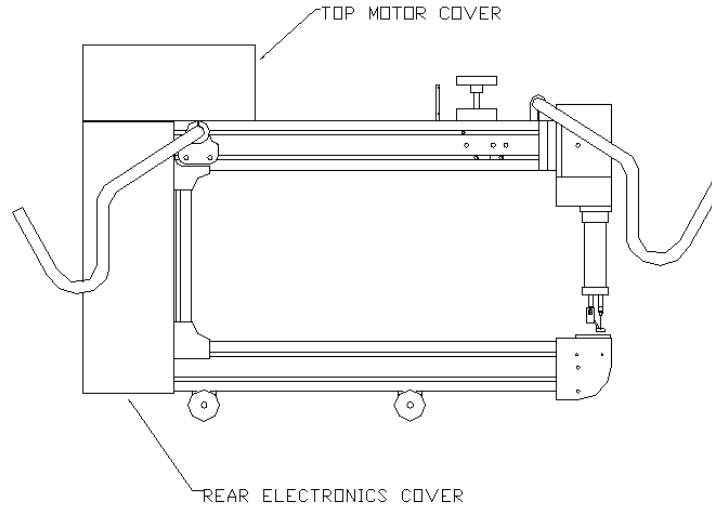

Step 2: Locate the Innova communication cable and terminal block. If double-sided tape is applied to the terminal block, remove the backing and attach the block in the position noted below. When attaching the terminal block to the machine, be sure that the communication cable is on the left side of the block and the unused, “open” terminals are facing to the right side of the machine. **NOTE: If double-sided tape is not provided, please use 5-minute epoxy to attach the terminal block to the machine. Epoxy provides a stronger bond and is the preferred method when autopilots are assembled at the factory. For packaging and shipping concerns, 5-minute epoxy is not included with the kit.**

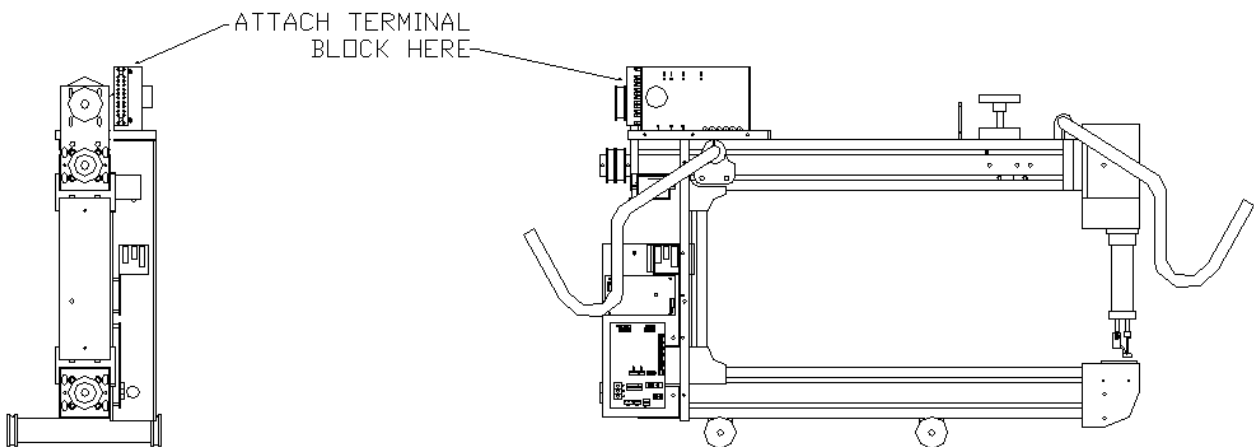

Step 3: Following the wiring diagram provided in the rear of this manual, connect the labeled terminal block locations to the corresponding PLC green terminals with the provided 18 AWG wire. Additionally, disconnect the (2) black 5-wire stitch regulator encoder cables from the rear of the PLC and connect them to the new gray terminal block. Make sure to connect the encoder that is located at the rear of the lower carriage to the terminals marked X and attach the encoder located in front of the Innova main ON/OFF switch to the terminals labeled Y.

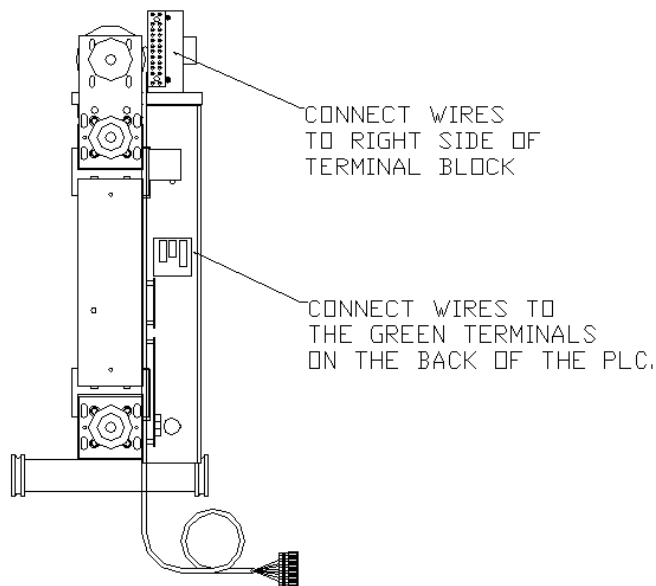

Step 4: Using the provided nylon ties, secure the communication cable and 18 AWG wires to the existing Innova wiring harness. Be sure to route and secure all of the wires so that they do not come in contact with any of the moving pulleys of belts on the machine.

Step 5: Nylon tie the communication cable to the bottom electronics cover plate. Use at least (2) nylon ties to secure the cable through the same holes to which the encoders and power cable are attached.

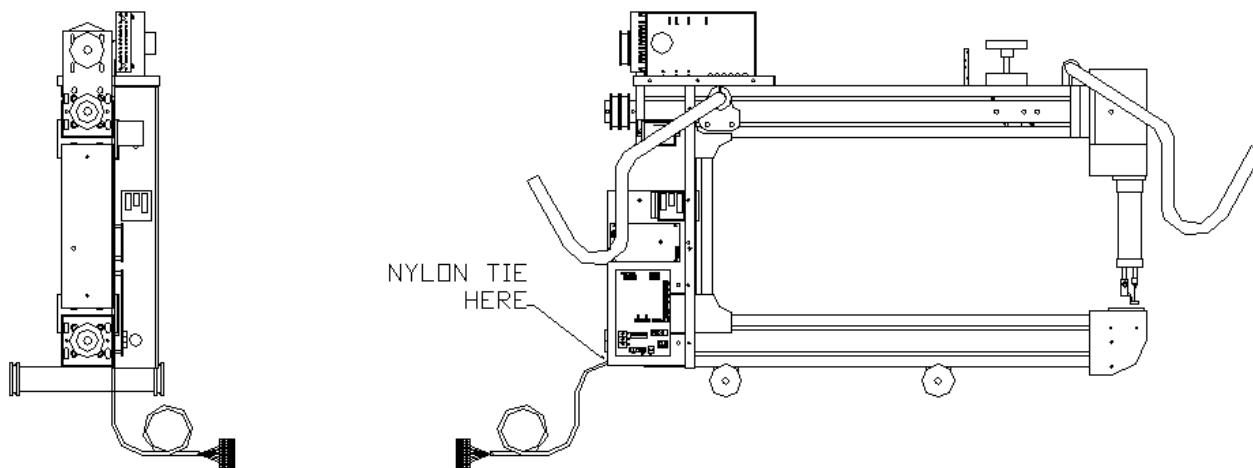

Step 6: Secure the communication cable to the black plastic wire tie mount on the rear of the Innova carriage. Provide enough slack for the machine to move freely and completely from the front to the back.

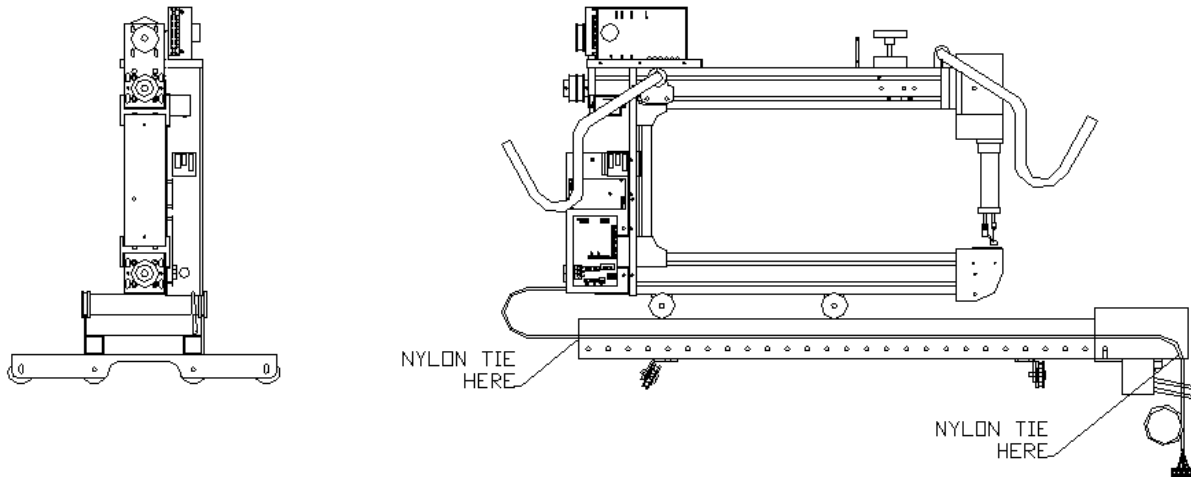

Step 7: MAKE A CHOICE:

**CABLES LOCATED AT THE REAR OF THE MACHINE:** Wire tie the communication cable to the power cord.

**CABLES LOCATED UNDER THE QUILT AT THE FRONT OF THE MACHINE:** Route and wire tie the communication cable along the inside to the lower carriage rail and the front of the carriage underneath the Y-axis motor guard. Make sure the communication cable does not rub on the pulleys and belts located at the front of the carriage. Nylon tie the cable to the hole provided in the left side of the motor guard.

## 5.0 Final Assembly

Step 1: **SEE SECTION 6.0 FOR 18" MACHINES.** Attach the 52" touchscreen beam to the left or right side of the frame in the location illustrated below. Use (3) ¼" x 2" socket head cap screws, (3) flat washers, (3) lock washers and (3) ¼" t-nuts.

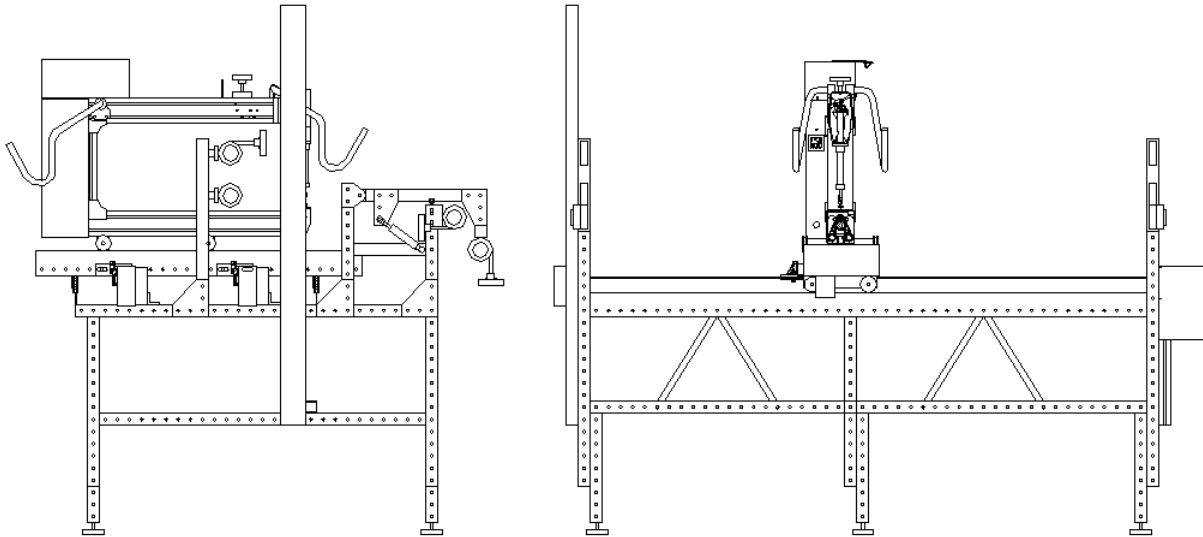

Step 2: Remove the front cover of the pushbutton station and install it onto the touch screen beam.

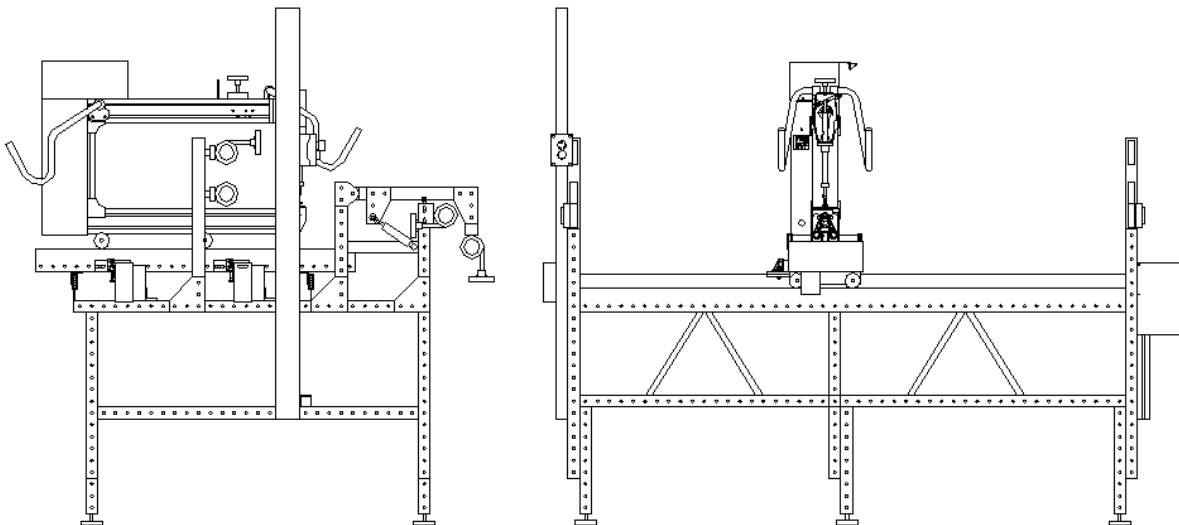



Step 3: Install the touch screen mount and the touch screen onto the beam.

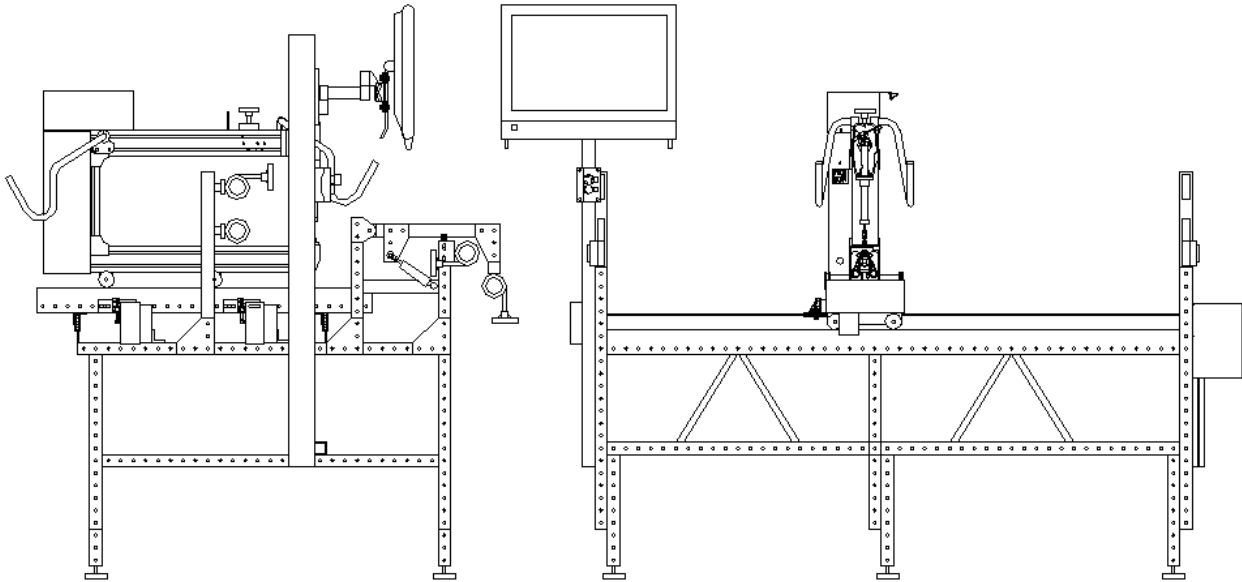

Step 4: Install the (2) control box shelf brackets using (2) 5/16 x 2" hex bolts and (2) flat washers. Position the shelf as close to the center leg of the frame as possible.

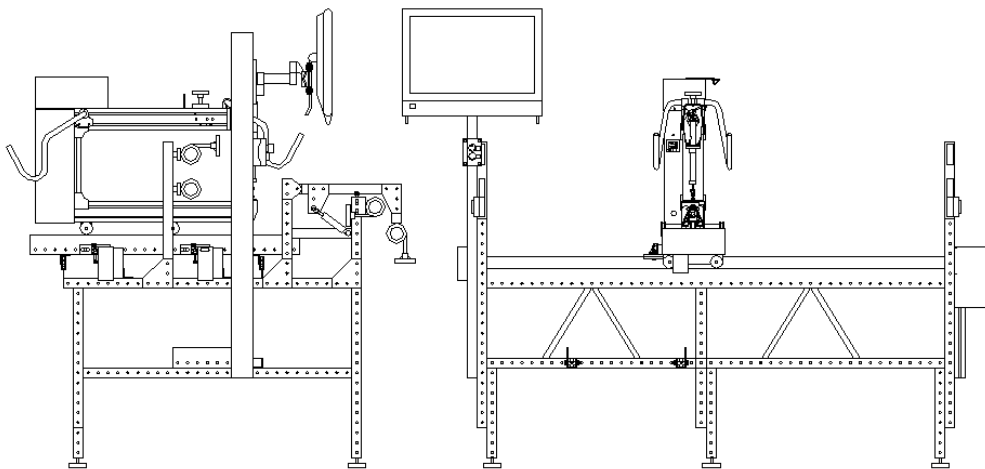

Step 5: Install the transformer brackets onto the transformer using (4) 8-32 x 1/2" bolts, (4) flat washers and (4) nylon insert lock nuts. Position the offset holes in the steel brackets as illustrated below.

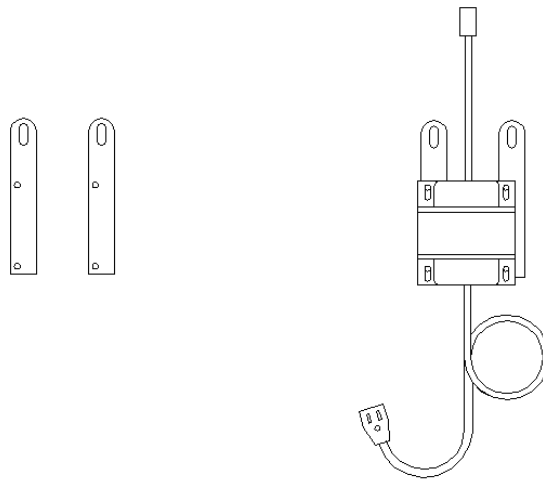

Step 6: Install the transformer onto the control box shelf using (2) 5/16 x 2-1/4" hex bolts, (4) flat washers and (2) nylon insert lock nuts.

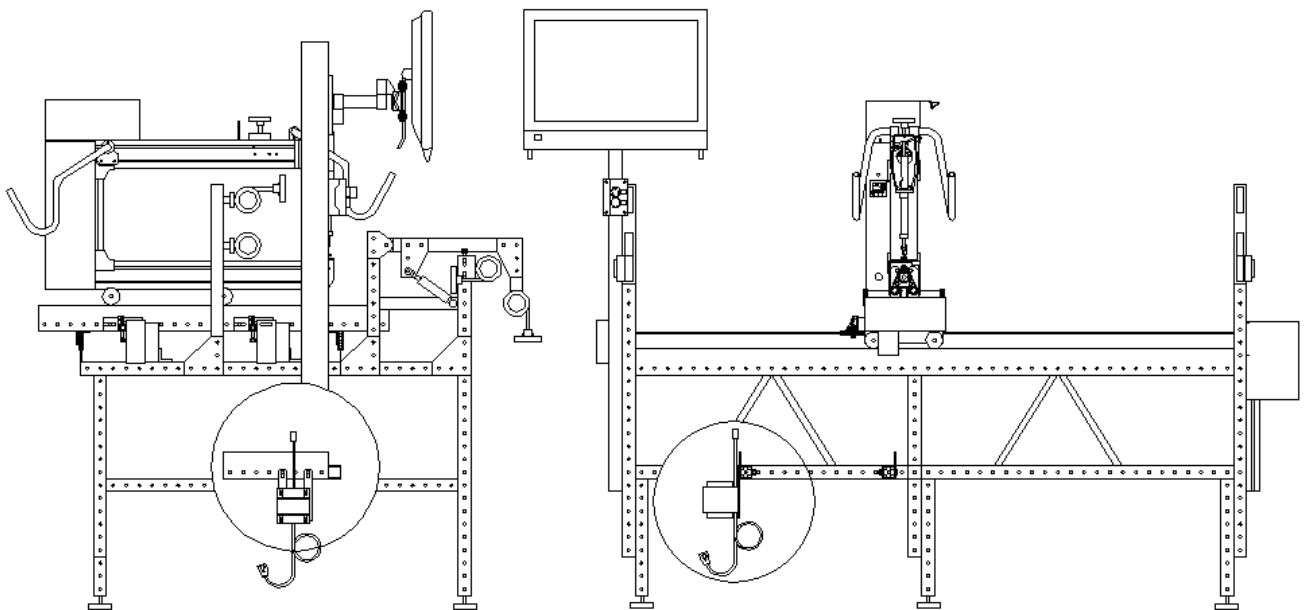

Step 7: Install the control box onto the shelf and locate it at far forward as possible. Take care not to drop the control box as cards and components inside may become loose and damage may result.

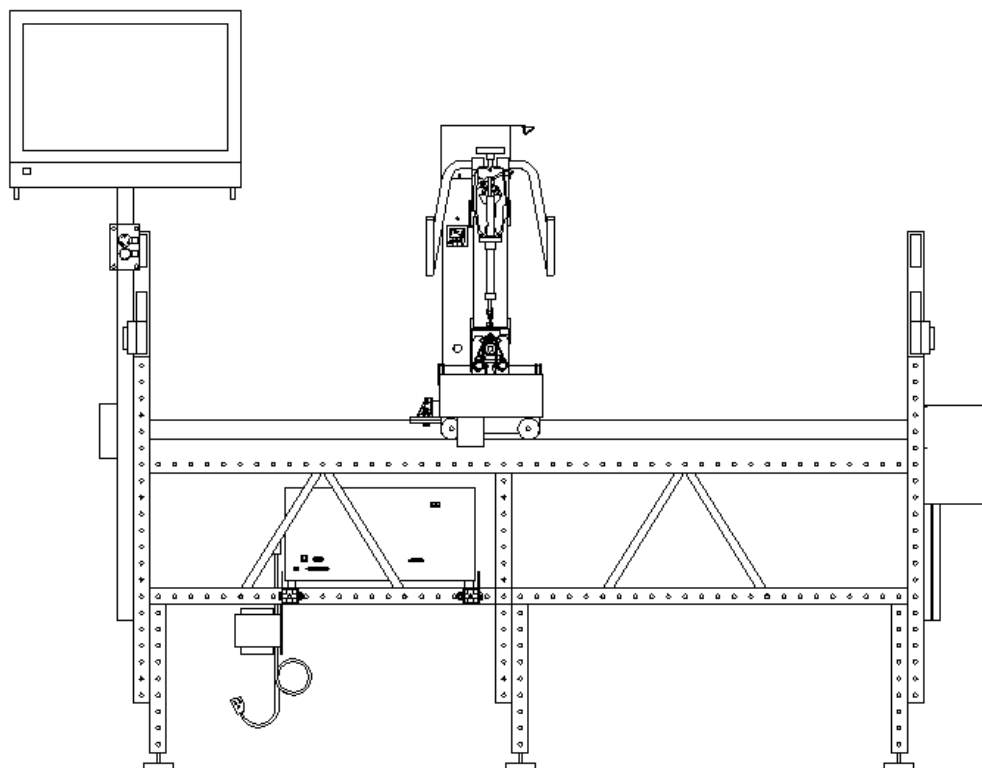

Step 8: Familiarize yourself with the terminals located on the front of the control box. Connect the transformer to the corresponding terminal.

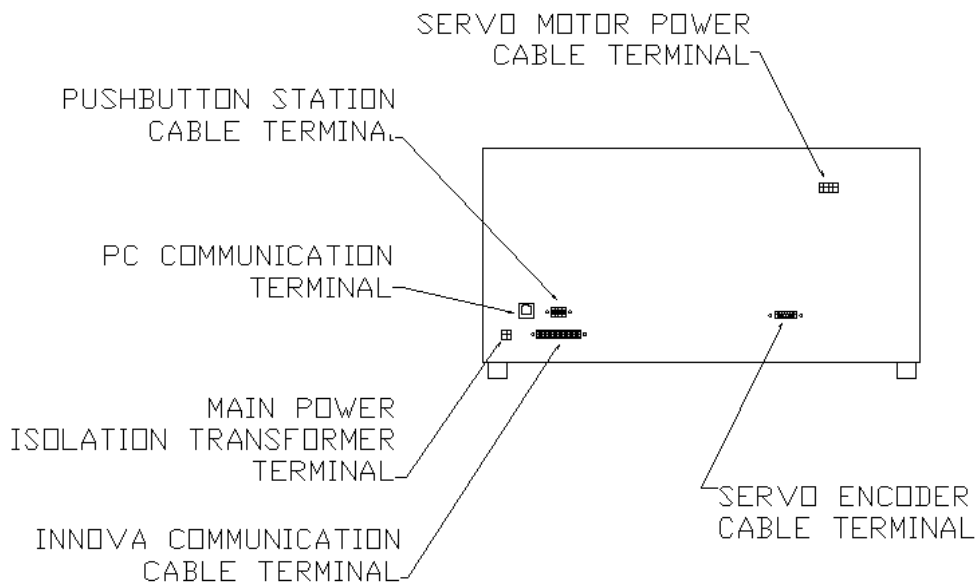

Step 9: Connect the Innova communication cable and the pushbutton station cable to the control box.

Step 10: Locate the servo motor and encoder cables and connect them to the control box. Route and wire tie the power and encoder cable labeled X to the X-motor and the cables labeled Y to the Y-motor. Make sure to wire tie the Y-motor cables to the hole provided in the left side of the motor guard. Failure to do so will cause strain on the motor connectors and premature failure of the plugs or motor.

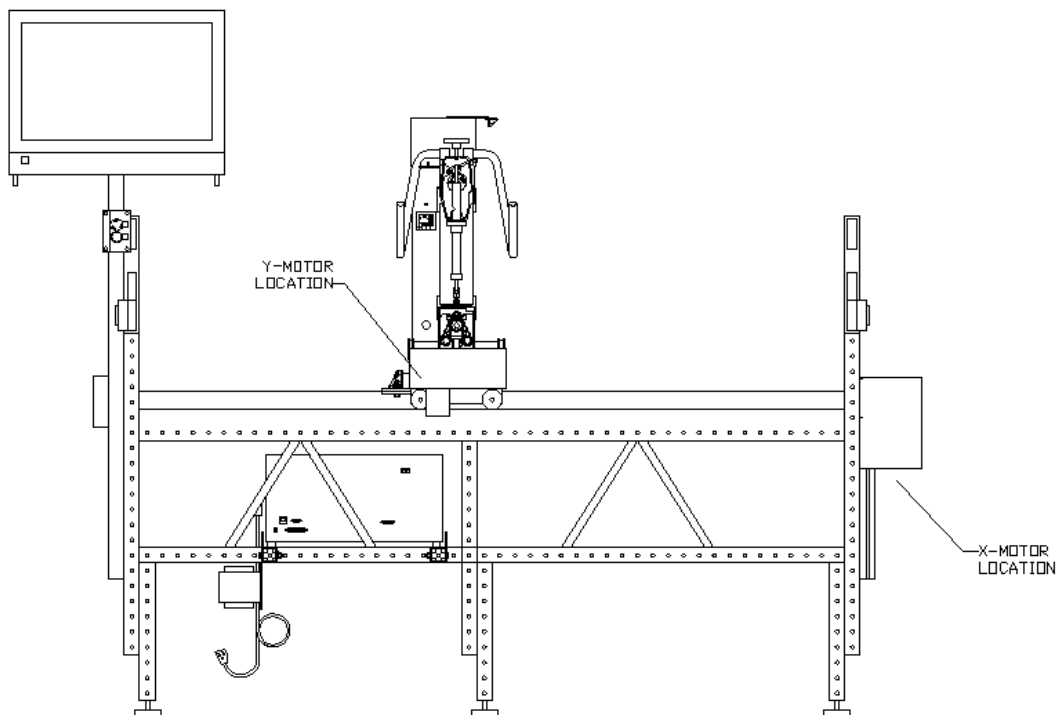

Step 11: Locate the computer power cord and the PC to Autopilot communication cable. Attach the power cord to the rear of the computer. Attach the USB end of the PC to Autopilot communication cable to one of the available USB ports on the rear of the computer. Using the (2) provided twist lock wire tie mounts, route and wire tie the PC cables and pushbutton station cable to the touch screen beam.

Step 12: Connect the PC to Autopilot communication cable phone plug end into the control box PC communication terminal.

Step 13: Confirm that the machine has a free range of motion and is not limited by any cables. Adjust the length of or re-route the cables if necessary.

Step 14: Coil up and secure any excess cabling to the frame using the provided wire ties. **NOTE: FAILURE TO DO SO MAY CAUSE A TRIPPING HAZARD AND/OR MACHINE DAMAGE.**

Step 15: Connect the PC and the Autopilot transformer power cords to an available 110V outlet.

### 6.0 18" Autopilot assembly modifications

#### SECTION 2.0 MODIFICATIONS FOR 18" ASSEMBLY

Step 4: MOVE THE RIGHT ANGLE BRACKET ON THE LEFT X-AXIS BEARING ASSEMBLY FROM THE LEFT SIDE TO THE RIGHT. Assemble (2) X-axis drive bearings assemblies with (2) medium drive pulleys and (1) large drive pulley. Make sure to place a key into the slot of the shaft for each of the pulleys. Leave the pulleys and bearing assemblies loose on the shaft. **DO NOT TIGHTEN THE SET SCREWS.**

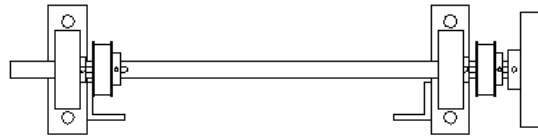

MOVE ANGLE BRACKET TO RIGHT  
SIDE OF BEARING ASSEMBLY

Step 5: Reverse the 5 hole gusset plate on the right side of the frame as illustrated below. Install the X-axis drive shaft assembly onto the right side of the frame. Attach the bearing assemblies at the 5<sup>th</sup> and 15<sup>th</sup> hole, from the back of the top side tube. Bolt the bearing assemblies using (2) 5/16 x 2" HEX bolts and (2) flat washers in the 5<sup>th</sup> and 15<sup>th</sup> hole from the bottom up. Additionally, use (2) 5/16 x 2-1/2" HEX bolts, (4) flat washers and (2) nylon insert lock nuts to secure the slotted angle brackets to the tube in the 6<sup>th</sup> and 14<sup>th</sup> hole. NOTE: Install the 2-1/2" bolts with the head of the bolt on the top side of the frame and the nut on the bottom side.

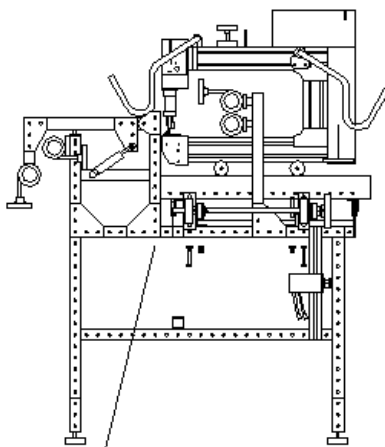

FLIP 5 HOLE  
GUSSET FORWARD

MOUNT BEARING ASSEMBLIES  
IN 5TH AND 15TH HOLE FROM REAR  
OF FRAME

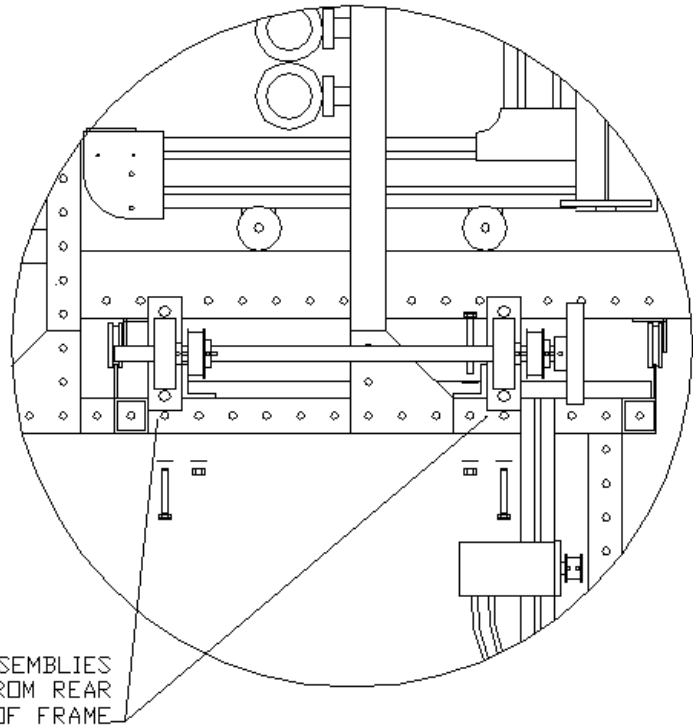

Step 6: Reverse one of the X-axis idler bearing assemblies to look like the assembly on the right in the magnified view. Install the (2) X-axis idler bearing assemblies with guards into the 5<sup>th</sup> and 12<sup>th</sup> hole from the rear of the left side of the frame. Use (2) 5/16 x 2" HEX bolts and (2) flat washers. Additionally, use (2) 5/16 x 2-1/2" HEX bolts, (4) flat washers and (2) nylon insert lock nuts to secure the slotted angle brackets to the tube in the 6<sup>th</sup> and 11<sup>th</sup> hole. NOTE: Install the 2-1/2" bolts with the head of the bolt on the top side of the frame and the nut on the bottom side.

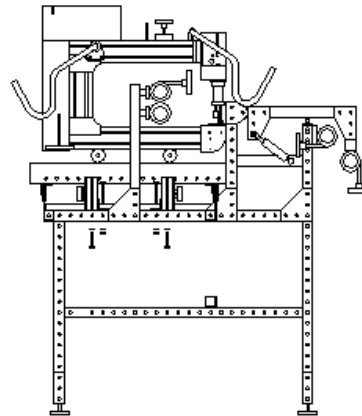
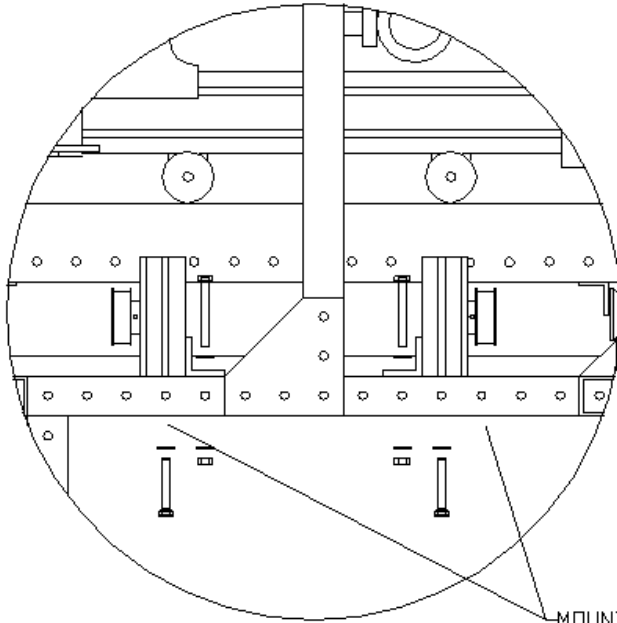

MOUNT IDLER BEARING ASSEMBLIES IN 5TH AND 12TH HOLE FROM REAR OF FRAME. BE SURE TO REVERSE FRONT IDLER BEARING ASSEMBLY AS ILLUSTRATED WITH 90 DEGREE ANGLE BRACKET ON THE LEFT SIDE OF THE ASSEMBLY

### SECTION 5.0 MODIFICATIONS FOR 18" AUTOPILOT

Step 1: Attach the 52" touchscreen beam to the left or right side of the frame in the location illustrated below. Use (2) 1-1/2 x 3 spacer blocks, (3) 1/4" x 3-1/2" socket head cap screws, (3) flat washers, (3) lock washers and (3) 1/4" t-nuts.

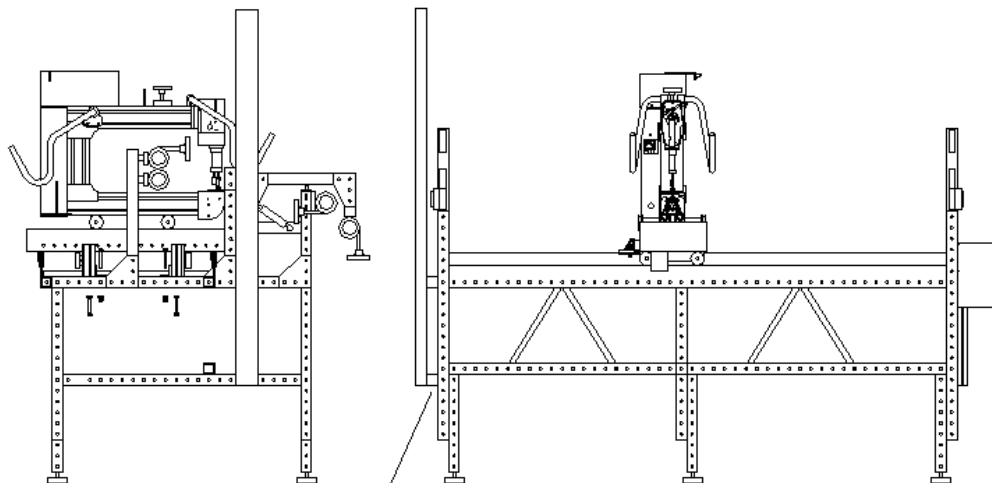

INSTALL 1.5' SPACERS BETWEEN TOUCHSCREEN BEAM AND FRAME



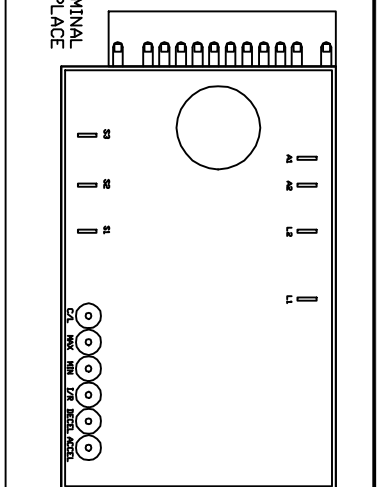
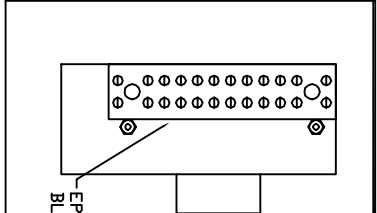
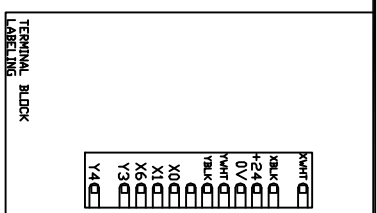
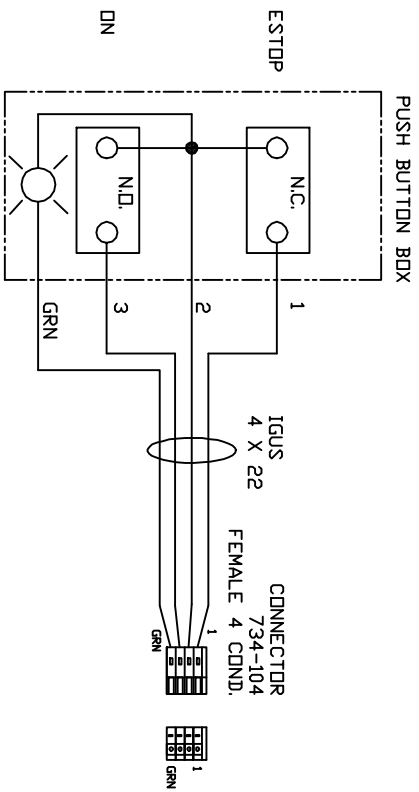

IMPORTANT NOTE: WHEN INSTALLING AN AUTOPILOT INTO MACHINES WITH THE NEW STYLE WHEEL BRACKETS, THE X WHT AND X BLK WIRES MUST BE SWAPPED. THIS MEANS THE WHITE WIRE MUST GO TO X BLK AND THE BLACK WIRE MUST GO TO X WHT. FAILURE TO DO SO WILL CAUSE INITIALIZATION ERRORS IN THE CONTROL BOX.

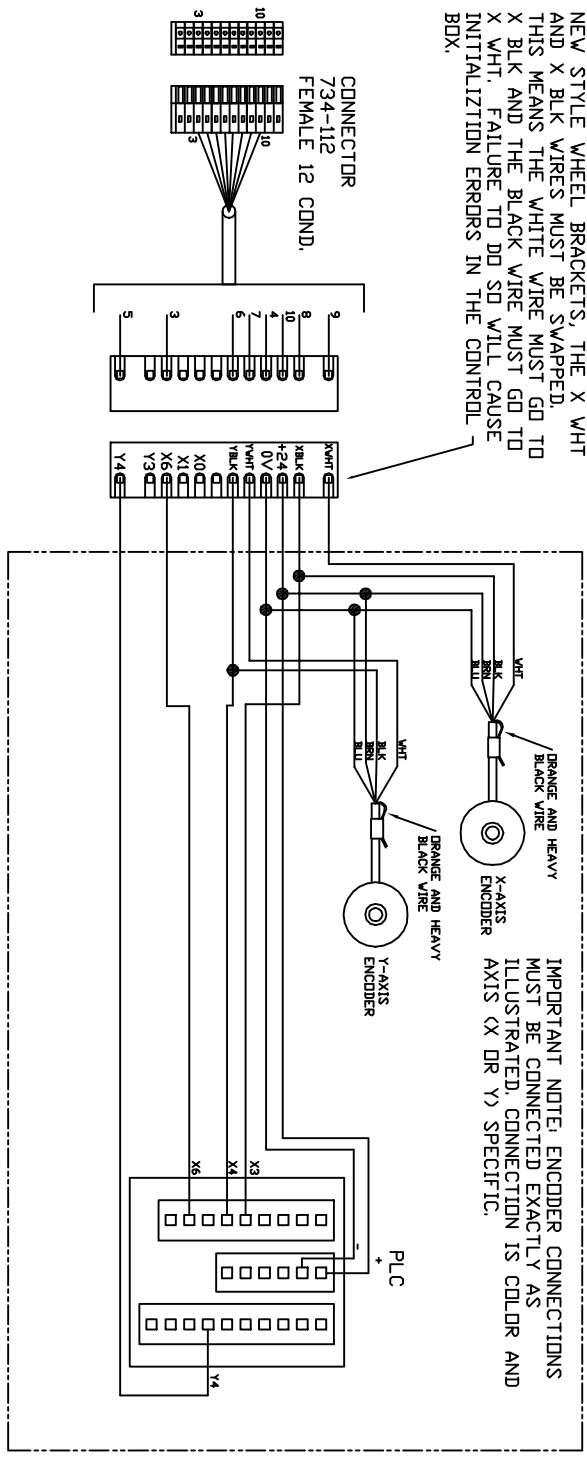

IMPORTANT NOTE: ENCODER CONNECTIONS MUST BE CONNECTED EXACTLY AS ILLUSTRATED. CONNECTION IS COLOR AND AXIS (X OR Y) SPECIFIC.

<p><b>INCHES</b> UNLESS OTHERWISE SPECIFIED</p>	
<p>ABM INTERNATIONAL ABM INTERNATIONAL, Inc. 211 SHERMAN AVENUE EATON BRIDGE WILSON, IL 60097</p>	
<p>TITLE: INNOVA TO AUTOPILOT CONTROL BOX</p>	
<p>DRAWN BY: JOE PODOLSKI</p>	<p>DATE: 3/4/09</p>
<p>CHECKED BY: PNO</p>	<p>SCALE: NONE</p>
<p>SHEET NO. 1</p>	<p>REV. NO. 2</p>
<p>E-PNO-001B</p>	



PUSHBUTTON STATION  
TD CONTROL BOX

CONNECTOR  
734-104  
FEMALE 4 COND.

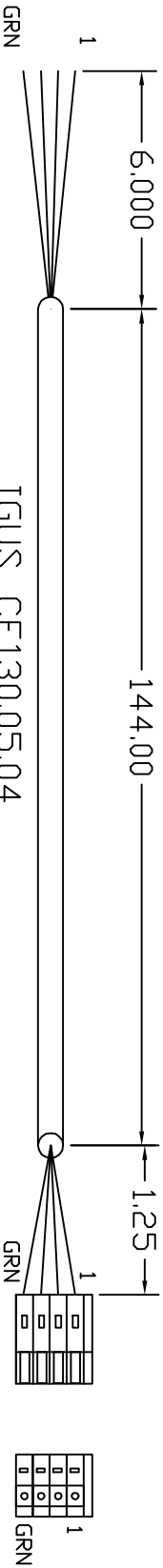

AUTOPILLOT TD  
INNOVA PLC CABLE A

CONNECTOR  
734-112  
FEMALE 12 COND.

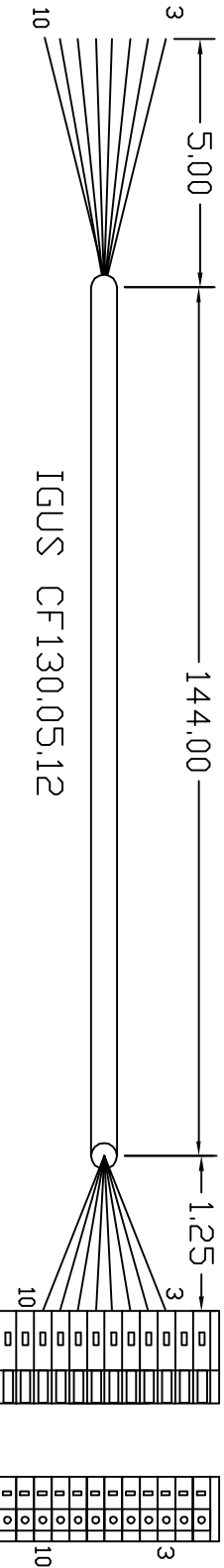

**INCHES**

ALL DIMENSIONS ARE IN INCHES  
UNLESS OTHERWISE SPECIFIED  
ALL DIMENSIONS ARE TO CENTER  
OF DIMENSION LINE UNLESS  
OTHERWISE SPECIFIED  
DIMENSIONS ARE TO CENTER  
OF DIMENSION LINE UNLESS  
OTHERWISE SPECIFIED  
DIMENSIONS ARE TO CENTER  
OF DIMENSION LINE UNLESS  
OTHERWISE SPECIFIED  
DIMENSIONS ARE TO CENTER  
OF DIMENSION LINE UNLESS  
OTHERWISE SPECIFIED  
DIMENSIONS ARE TO CENTER  
OF DIMENSION LINE UNLESS  
OTHERWISE SPECIFIED

ABM INTERNATIONAL

ABM INTERNATIONAL, Inc.  
211 SHERMAN AVENUE  
EATON BRIDGE WILSON, IL 60097

AUTOPILLOT ELECTRICAL

INNOVA

DRAWN BY: JOE PODOLSKI DATE: 1/20/08

CHECKED BY: PNO  
SCALE: NONE  
DATE: -

2 2 E-PNO-001