

MAGNIFIER

1.0: Parts List

Long faceplate screw (Qty. 1) 

Flat washer (Qty. 3)

M4 x 18 mm socket head cap screw (Qty. 1)

Magnifying lens assembly (Qty. 1)

Ball mount – *part of Magnifying lens assembly* (Qty. 1) 

2.0: Installation

Step 1: Choose where the magnifier will be installed.

- 1) Though ABM does not recommend it, if the machine is equipped with an LED light assembly and you would like to install the magnifier on it, use the provided M4 socket head cap screw and install as illustrated below.

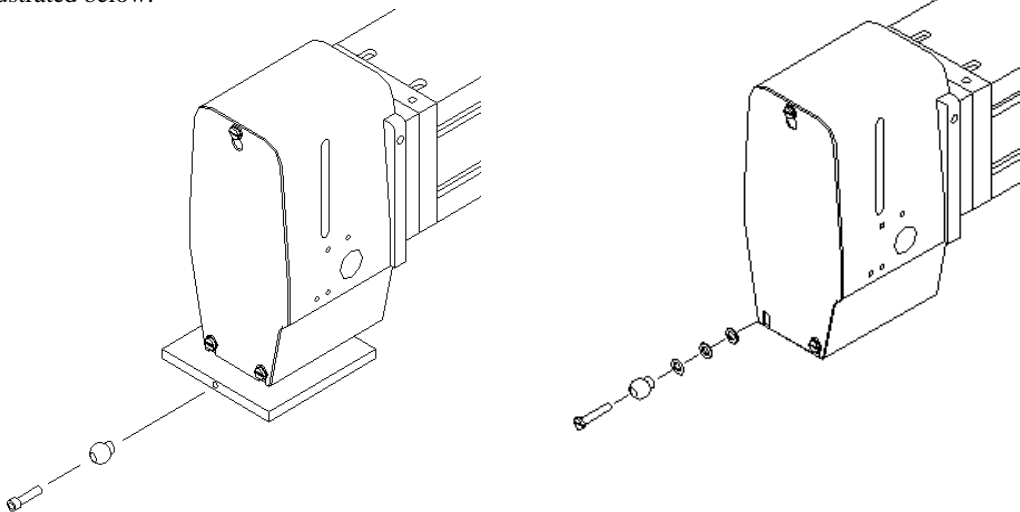

- 2) If you would like to install the magnifier onto the face plate, select the screw the magnifier will be installed on. **NOTE: FOR ILLUSTRATION PURPOSES, THE INSTRUCTIONS INSTALL THE MAGNIFIER ON THE LOWER LEFT FACE PLATE SCREW.**

Step 2: Remove the desired faceplate screw from the machine.

Step 3: Install the ball mount onto the machine using the supplied long faceplate screw. **NOTE: IF THE MACHINE IS EQUIPPED WITH A PAINTED METAL FACEPLATE, USE THE INCLUDED (3) FLAT WASHERS BETWEEN THE FACEPLATE AND THE BALL MOUNT. FAILURE TO USE THE FLAT WASHERS WILL CAUSE THE BALL MOUNT TO BE LOOSE AND CAN CAUSE POSSIBLE DAMAGE TO THE THREADED HOLE OF THE MACHINE.**

Step 4: Install the magnifying lens assembly onto the ball mount. Adjust the magnifier to the desired position by loosening the (2) 1/4" socket head cap screws on the ball clamp brackets. Re-tighten the (2) 1/4" screws once the desired position is achieved. **CAUTION: ATTEMPTING TO ADJUST THE MAGNIFIER WITHOUT LOOSENING THE (2) 1/4" SCREWS CAN CAUSE DAMAGE TO THE MACHINE OR THE MAGNIFIER.**

