

ABM International, Inc.

Navigator Assembly Manual

1.0: Parts List

Tablet (Qty. 1)

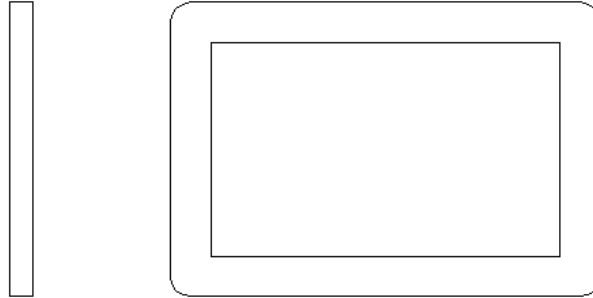

Tablet mount (Qty. 1) – NOTE: Mount may appear and operate different then image below

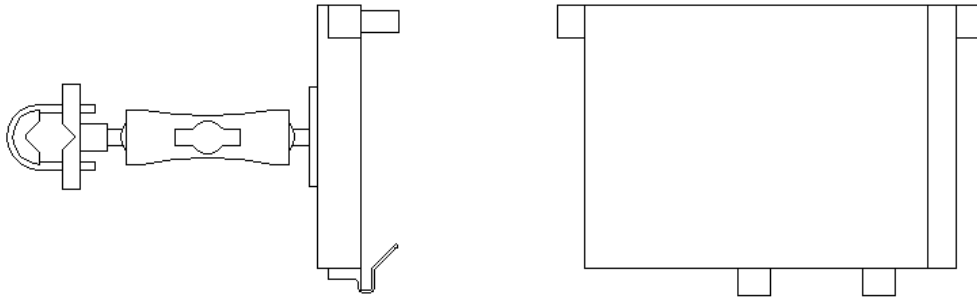

Control Box (Qty. 1)

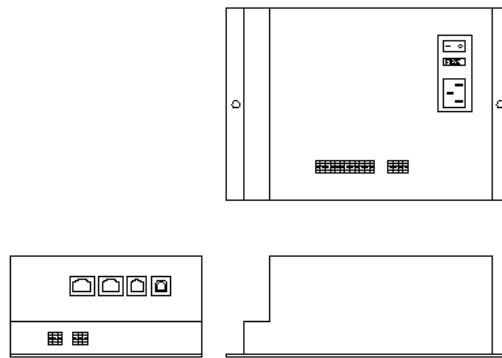

Motor Power Supply (Qty. 1)

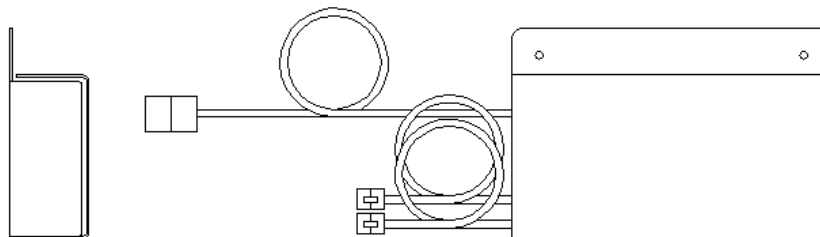

X-axis motor assembly and plate (Qty. 1)

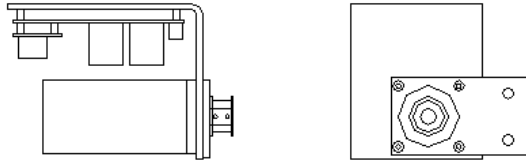

Y-axis motor assembly and plate (Qty. 1)

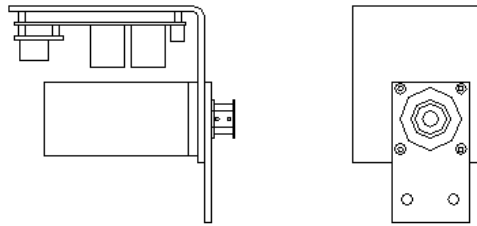

X and Y-axis communication cable (Qty. 2)

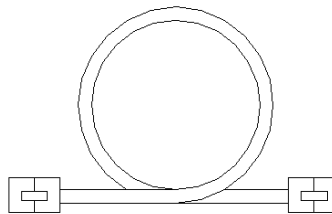

Controller power cord (Qty. 1)

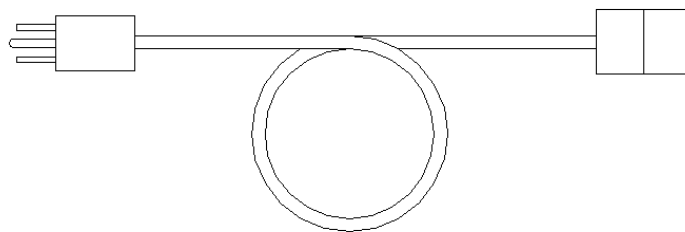

Tablet to Navigator communication cable – USB A to USB B (Qty. 1)

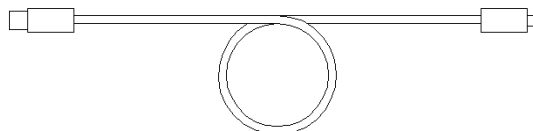

Pushbutton station (Qty. 1)

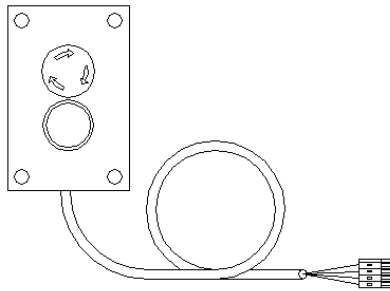

Innova communication cable with terminal block (Qty. 1) – NOTE: May be installed on Innova from factory.

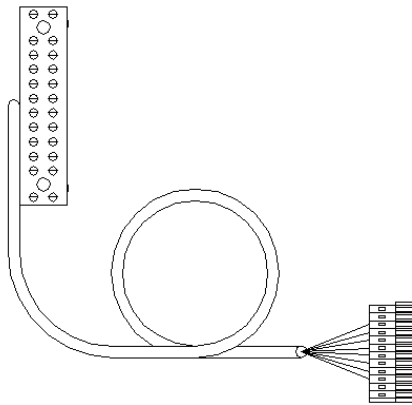

X-axis t-slotted beam (Qty. 1)

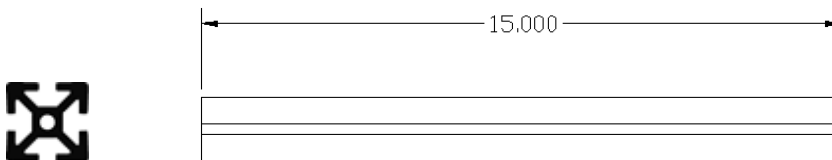

X-axis quick disconnect clamp (Qty. 2)

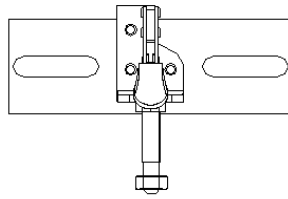

Y-axis quick disconnect clamp (Qty. 1)

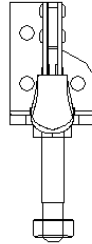

X-axis timing belt clamp plate (Qty. 2)

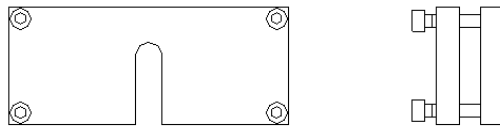

Y-axis timing belt clamp plate (Qty. 1)

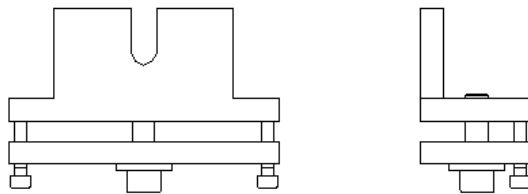

Carriage support cross block and plate (Qty. 1)

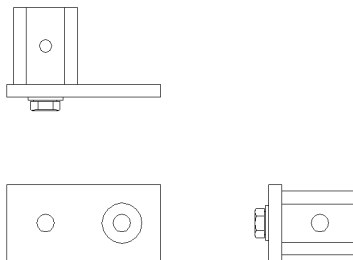

X-axis drive shaft (Qty. 1)



Large drive pulley (Qty. 1)

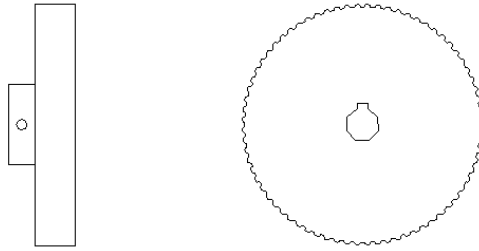

Medium drive pulley (Qty. 2)

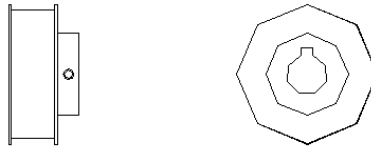

Y-axis drive pulley assembly (Qty. 1)

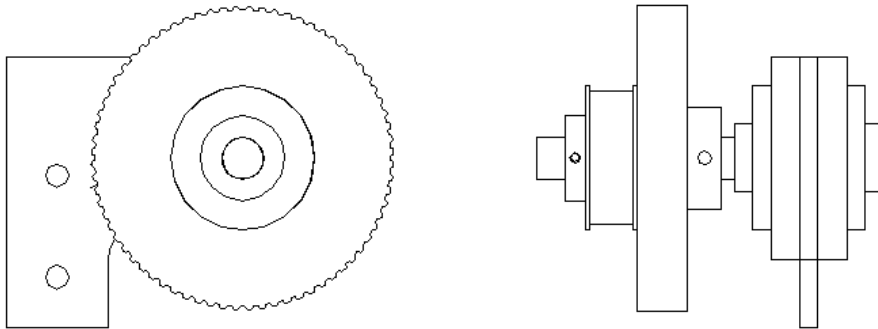

Y-axis idler pulley assembly (Qty. 1)

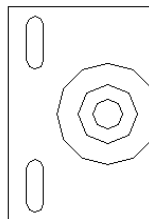

X-axis drive bearing assembly (Qty. 2)

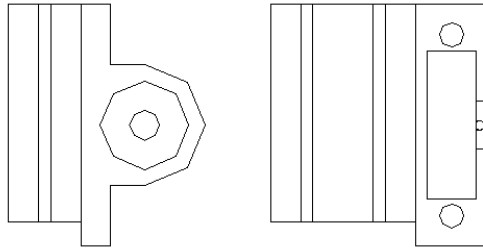

X-axis idler bearing assembly with guard (Qty. 2)

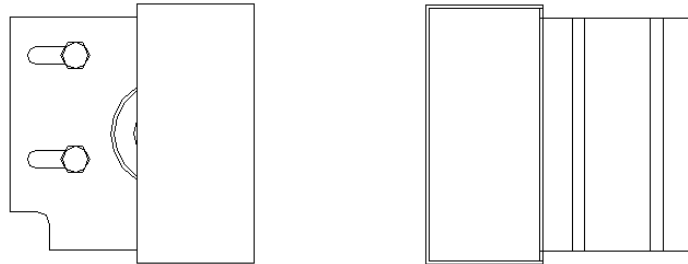

Y-axis motor guard (Qty. 1)

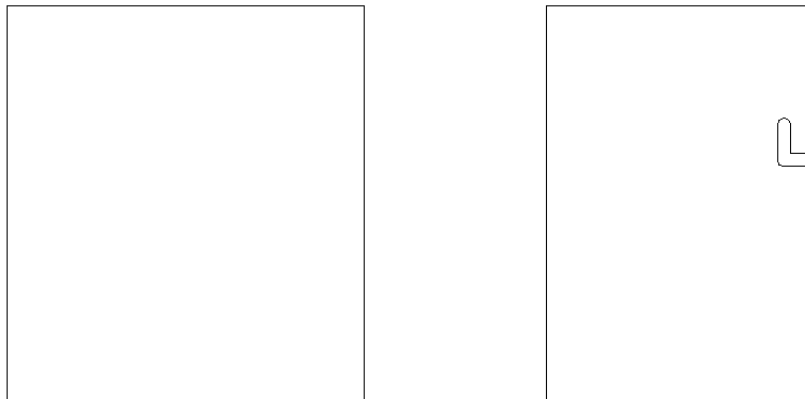

X-axis motor guard (Qty. 1)

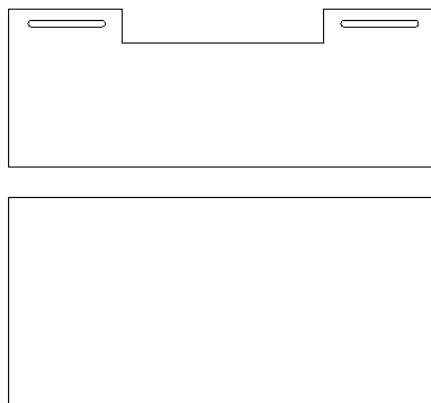

X-axis timing belt (Qty. 2)

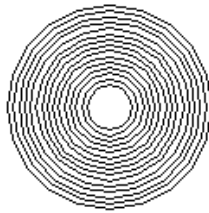

Y-axis timing belt (Qty. 1)

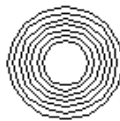

X and Y-axis main timing belt (Qty. 2)

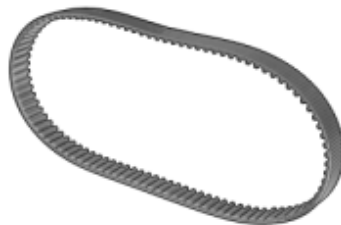

3/16 x 3/16 machine key (Qty. 3)

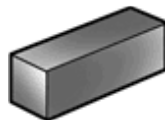

Twist lock cable tie holder (Qty. 2)



2.0 X-axis Assembly

NOTE: THESE INSTRUCTIONS ARE INTENDED FOR FRAMES ASSEMBLED WITH INSTRUCTION VERSION 19 OR NEWER. THE NAVIGATOR ASSEMBLY MANUAL DEMONSTRATES HOW TO INSTALL A MANUAL ON A 26" INNOVA. ASSEMBLY OF A NAVIGATOR ON AN 18" OR 22" INNOVA WILL DIFFER SLIGHTLY IN SOME STEPS. SEE SECTION 6.0 FOR AMENDMENTS TO INSTALLATION OF A NAVIGATOR FOR 18" MACHINES.

Step 1: Install the X-axis motor assembly onto the 15" t-slotted beam using (2) 5/16 x 3/4" HEX bolts, (2) flat washers and (2) 5/16 T-nuts. Locate the plate in the center of the beam. **NOTE: MAKE SURE TO USE THE X-AXIS MOTOR ASSEMBLY. THE MOUNTING PLATE POSITION VARIES SLIGHTLY FROM BETWEEN THE X AND Y-AXIS.**

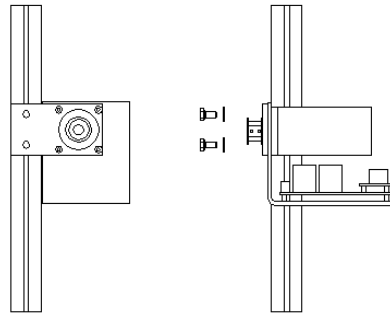

Step 2: **SEE SECTION 6.0 FOR 18" MACHINES.** Install the 15" X-axis t-slotted beam onto the right side of the frame in the seventh hole for a 26" machine or the ninth hole for a 22" machine measured from the rear of the machine at the top frame beam. Use (2) 5/16 x 2" HEX bolts, (2) flat washers and (2) 5/16 T-nuts.

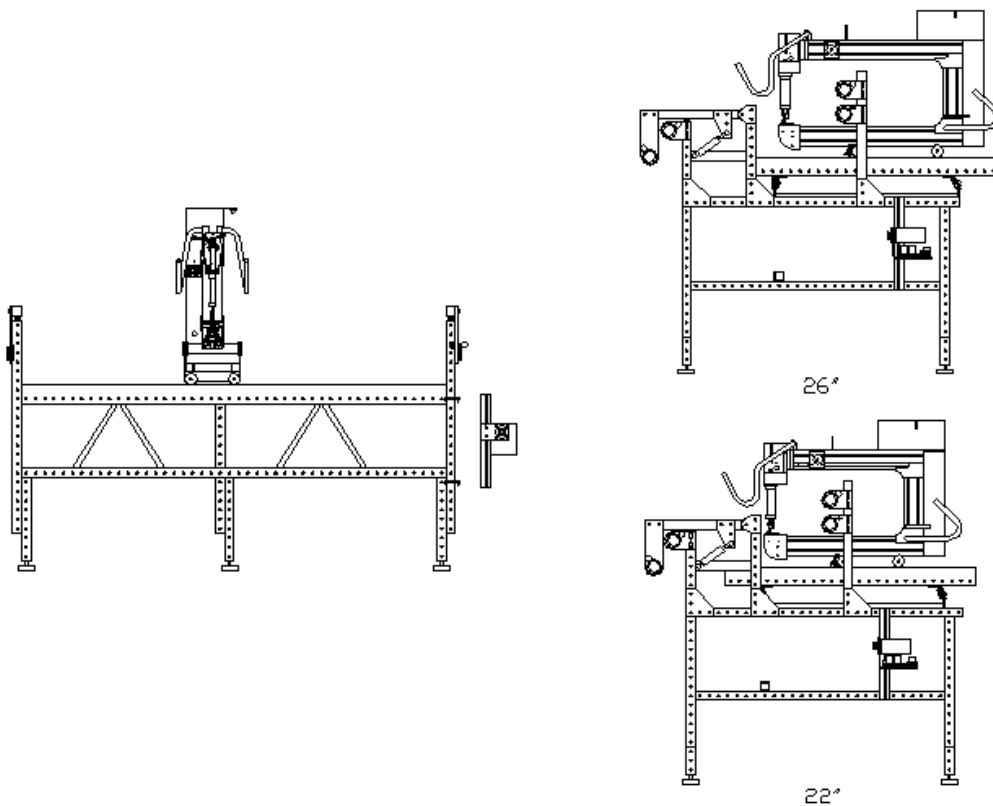

Step 3: **SEE SECTION 6.0 FOR 18" MACHINES.** Assemble (2) X-axis drive bearings assemblies with (2) medium drive pulleys and (1) large drive pulley. Make sure to place a key into the slot of the shaft for each of the pulleys. Leave the pulleys and bearing assemblies loose on the shaft. Drape the X-axis main timing belt onto the center of the shaft. **DO NOT TIGHTEN THE SET SCREWS.**

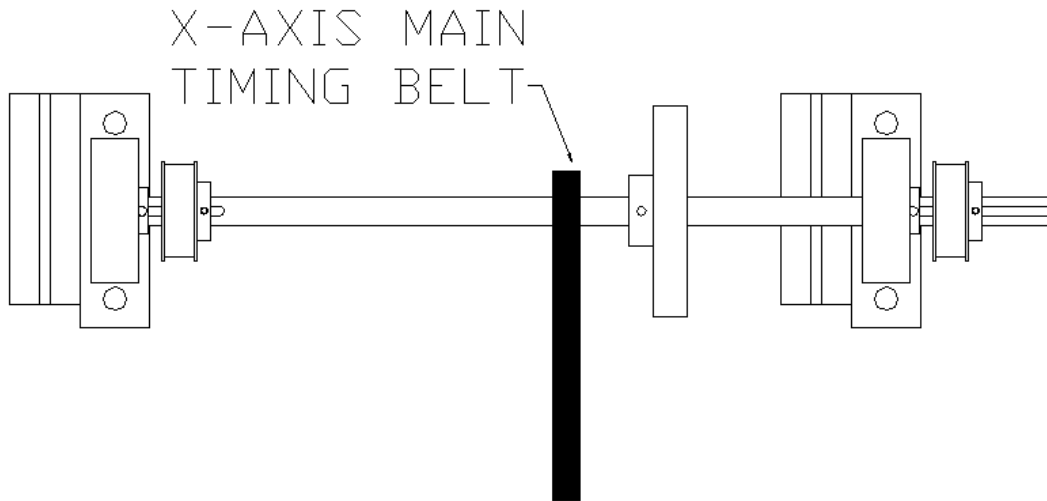

Step 4: **SEE SECTION 6.0 FOR 18" MACHINES.** With the X-axis main timing belt installed on the large pulley, install the X-axis drive shaft assembly onto the right side of the frame. For a 26" machine, attach the bearing assemblies at the 5th and 6th holes for the rear bearing and 16th and 17th hole for the front bearing, counting from the back of the top side tube. For a 22" machine, attach the bearing assemblies at the 7th and 8th holes for the rear bearing and 18th and 19th hole for the front bearing, counting from the back of the top side tube. Bolt the bearing assemblies using (4) 5/16 x 2" HEX bolts and (4) flat washers from the bottom up.

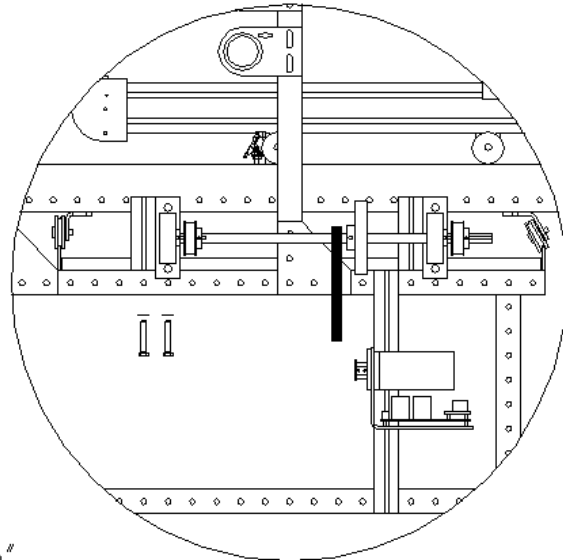
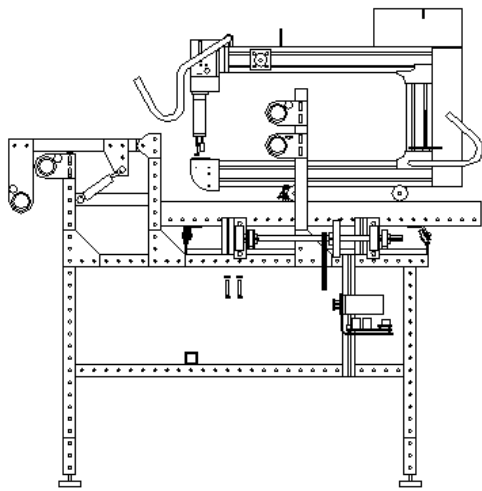

26"

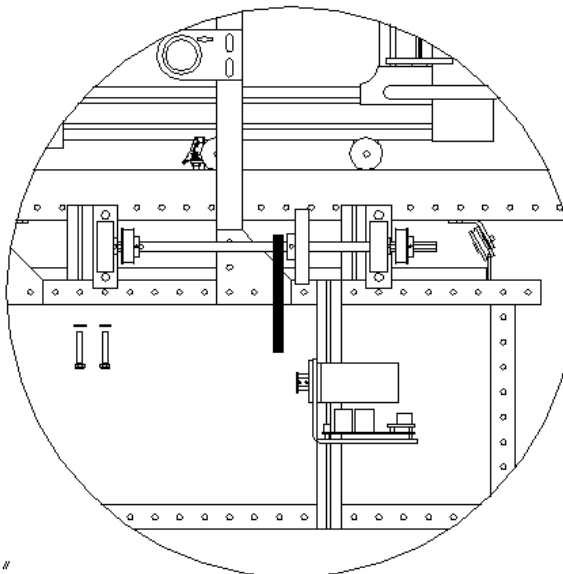
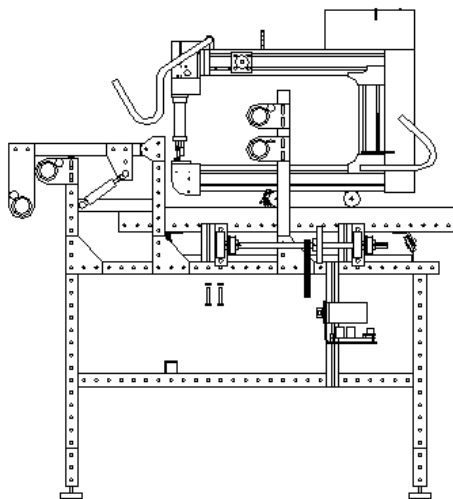

22"

Step 5: **SEE SECTION 6.0 FOR 18" MACHINES.** Install the (2) X-axis idler bearing assemblies with guards. For 26" machines, install them into the 5th and 6th holes for the rear assembly and 16th and 17th hole for the front assembly counting from the rear of the left side of the frame. For 22" machines, install them into the 7th and 8th holes for the rear assembly and 18th and 19th hole for the front assembly counting from the rear of the left side of the frame. Use (4) 5/16 x 2" HEX bolts and (4) flat washers. If the X-axis idler pulleys did not come with the guards installed, install the guards onto the assemblies using (4) 1/4" button head bolts and (4) flat washers.

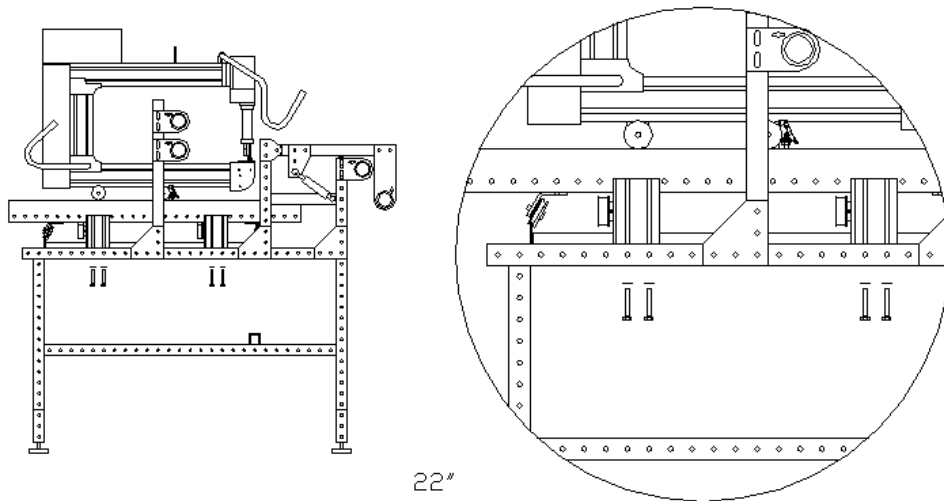
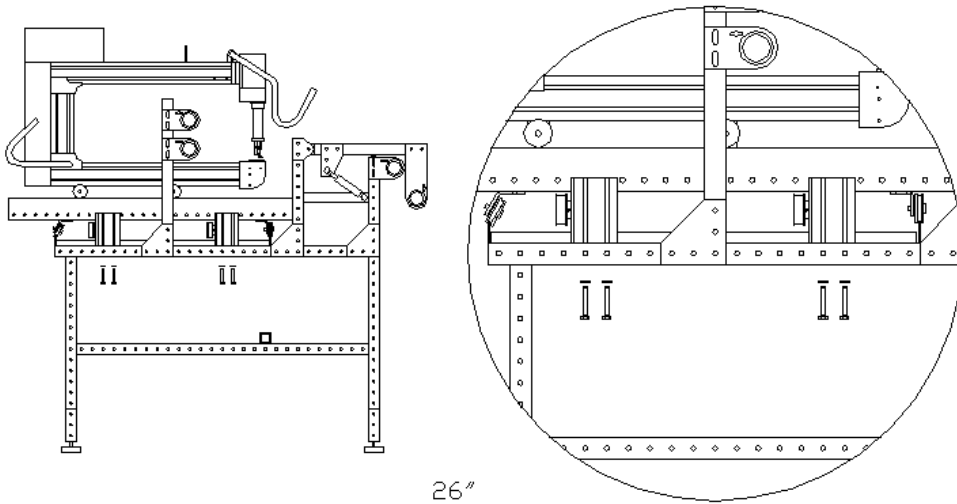

Step 6: Using (4) 5/16 x 2-3/4" HEX bolts, (4) flat washers and (4) nylon insert lock nuts, install the X-axis quick disconnect clamp brackets onto the left side of the lower carriage. Install the brackets so that the red handled clamp is aligned with the center of the idler pulleys on the left side of the machine.

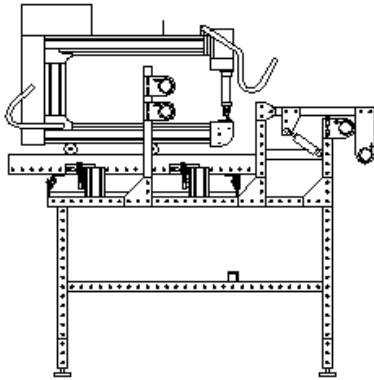

26

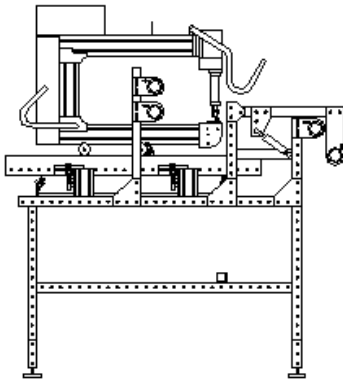

22

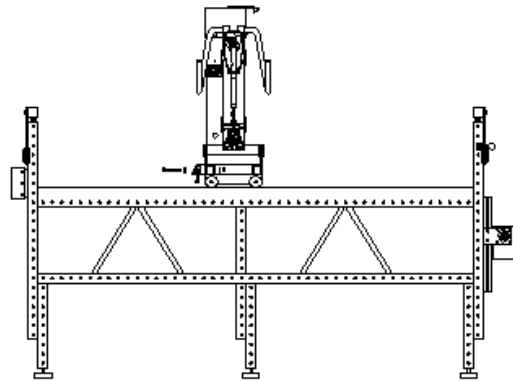

Step 7: Install the X-axis timing belt clamp onto the X-axis quick disconnect clamp. **NOTE: INSTALL THE CLAMP PLATE SO THAT THE SIDE WITH THE SMALL SLOT IS FACING UP.** Lift the red handle and check to make sure the clamp grips the plate assembly firmly. If the plate is loose, use a 7/16 wrench to tighten the hex nut on the bottom end of the clamp. **DO NOT OVERTIGHTEN OR THE CLAMP WILL BEND WHEN YOU ATTEMPT TO LOCK THE PLATE IN PLACE.**

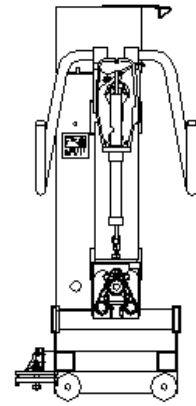
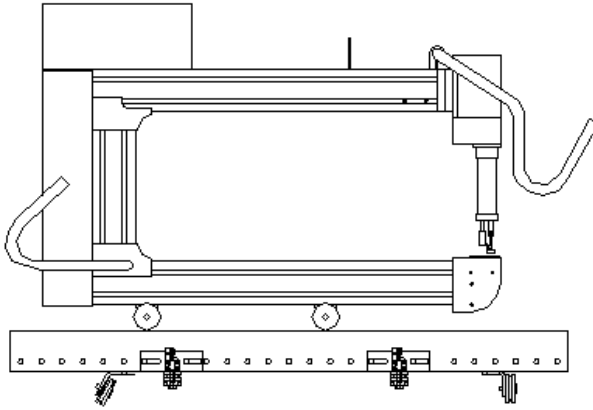

Step 8: Lay the white X-axis timing belts on the frame table with the teeth facing up. On the right side of the frame, pass the timing belt around the medium drive pulleys and secure to the belt clamp plates on the carriage. **NOTE: THE BELT WILL PASS UNDER THE CARRIAGE AND CONNECT TO THE CLAMP PLATES MOUNTED ON THE LEFT SIDE OF CARRIAGE.** Pass the left end of timing belt around the idler pulley assemblies and attach to the timing belt clamp plate. Tighten the timing belt clamp plate bolts and check to make sure that both timing belt clamp plates are equidistant from the left end. Jump the belt over the pulley on the drive end to align the clamp plates.

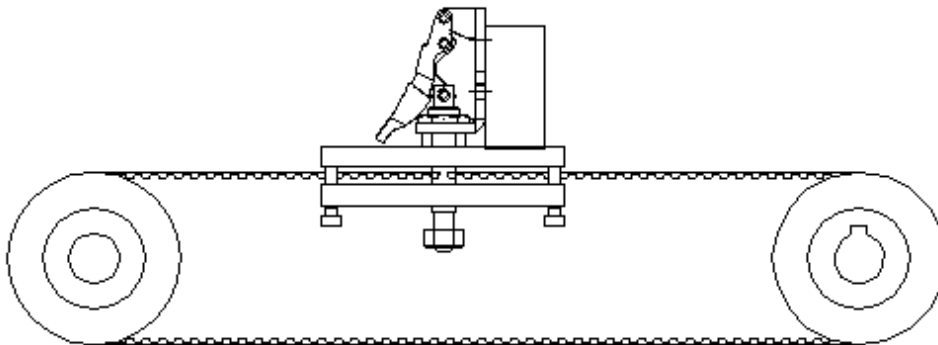

Step 9: Tighten the belts by loosening the (2) 5/16 HEX head bolts on the slotted idler bearing plates and pulling the plates out away from the frame.

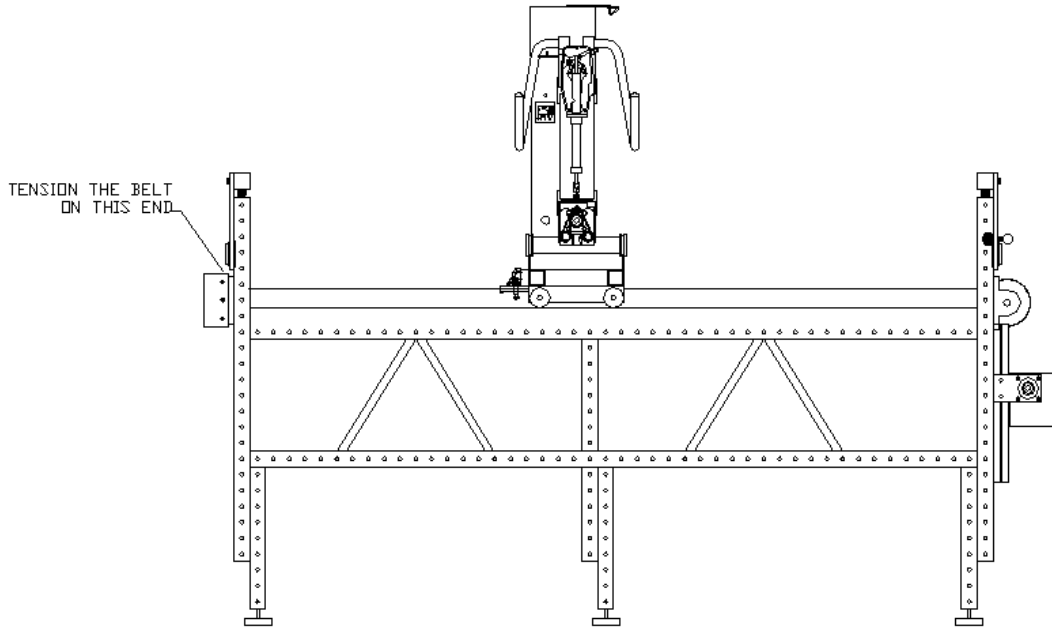

Step 10: Loosen the X-axis motor plate and slide the motor as high as possible on the slotted beam. Install the black X-axis main timing belt onto the motor pulley as well as the large drive pulley. Slide the large pulley on the shaft to align the large pulley and motor pulley. Tighten the set screws on the large pulley. Pull down on the motor plate to tension the black belt and tighten the (2) HEX bolts on the motor plate. **NOTE: THE BELT SHOULD BE TIGHTENED SO THAT RESISTANCE IS FELT WHEN YOU PRESS ON THE UNSUPPORTED SECTION OF THE BELT. THE BELT SHOULD BE TIGHT.**

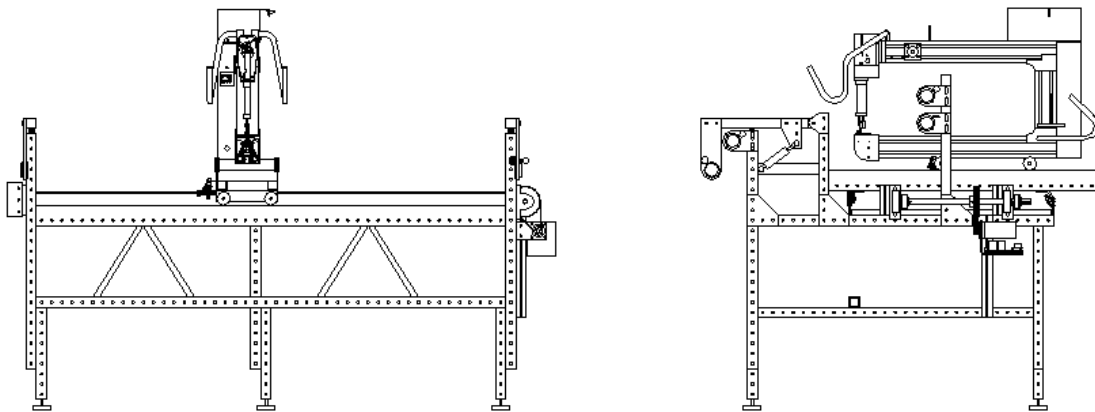

Step 11: Align the medium drive pulleys so the white X-axis timing belt is straight down the length of the frame. Ensure that all of the drive pulleys have keys in the keyways and tighten all (8) set screws, (4) on the medium drive pulleys and (4) on the bearing assemblies.

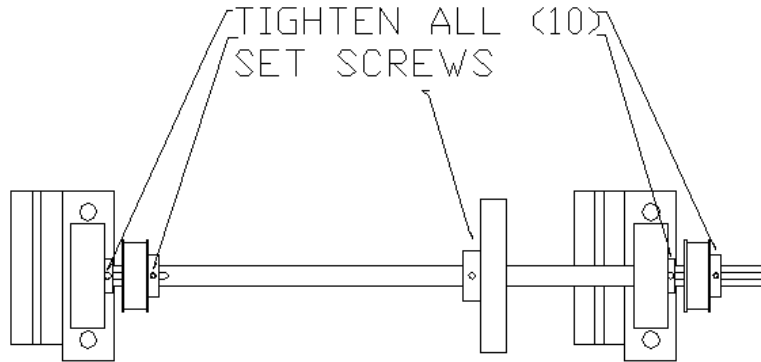

Step 12: Connect the communication cable and the power cable to the x-axis motor assembly. Leave the excess cable coiled up and out of the way for now.

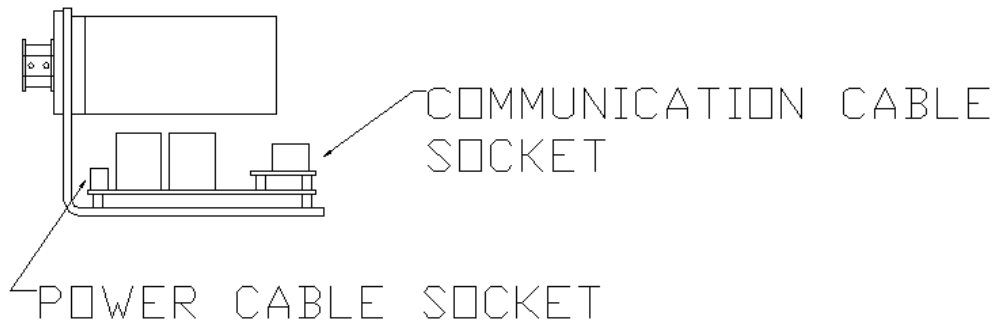

Step 13: Install the X-axis motor guard onto the right side of the frame. The slots in the top of the guard will align with the tapped holes in the t-slotted beams of the bearing assemblies. Use (2) 5/16 x 3/4" HEX bolts, (2) lock washers, and (2) flat washers to secure the guard.

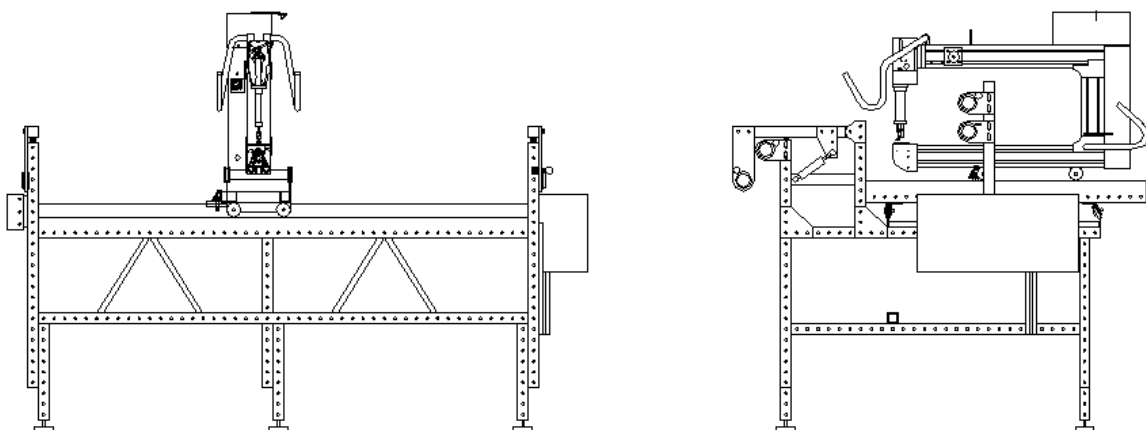

3.0 Y-Axis assembly

Step 1: In order to complete the installation of the Y-axis assembly onto an Innova, the front 6" t-slotted beam of the lower carriage must be located at the extreme front of the carriage. If the front beam is not in this position, please relocate it now.

Remove both hex head bolts on the either side of the carriage that hold the front t-slotted beam and remove the beam. Install (2) 5/16 t-nuts in the top of the beam, (1) 5/16 t-nut in the front face of the beam and (2) 5/16 t-nuts in the bottom of the beam. Re-install the beam in the first hole at the front of the carriage. Install the carriage support cross block into the front end of the left carriage rail and pass the original bolt holding the t-slotted beam through it and secure. Using a 5/16 x 3/4" hex head bolt and flat washer attach the cross block plate to the front face of the t-slotted beam. Make sure to tighten both sides of the 6" t-slotted beam to either lower carriage rail.

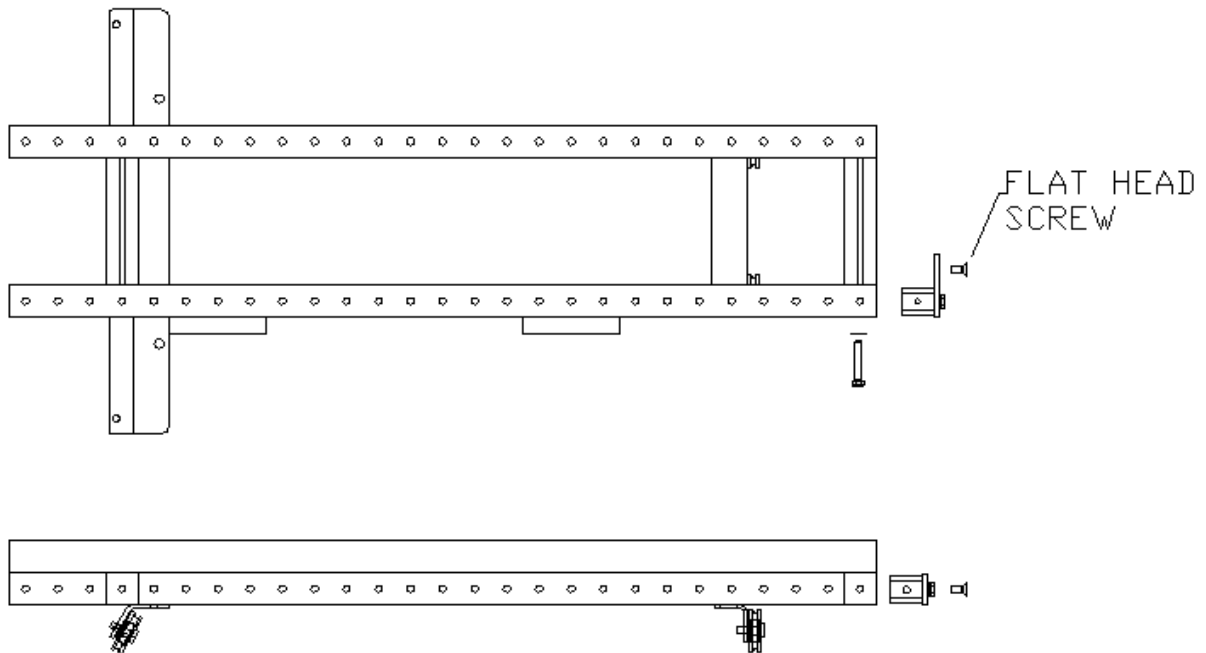

Step 2: Install the Y-axis drive pulley assembly to lower side of the front t-slotted beam using (2) 5/16 x 3/4" hex head bolts and flat washers. Adjust the assembly so the large diameter pulley is flush to outside of the lower carriage right rail. Tighten the bolts.

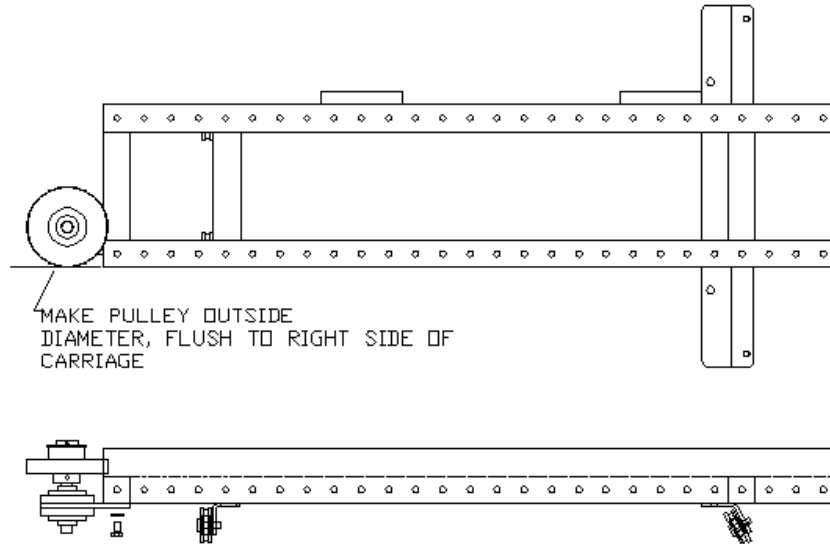

Step 3: Install the Y-axis motor assembly onto the top side of the front t-slotted beam using (2) 5/16 x 3/4" hex head bolts, (2) flat washers and (2) 5/16 t-nuts previously installed in the beam.

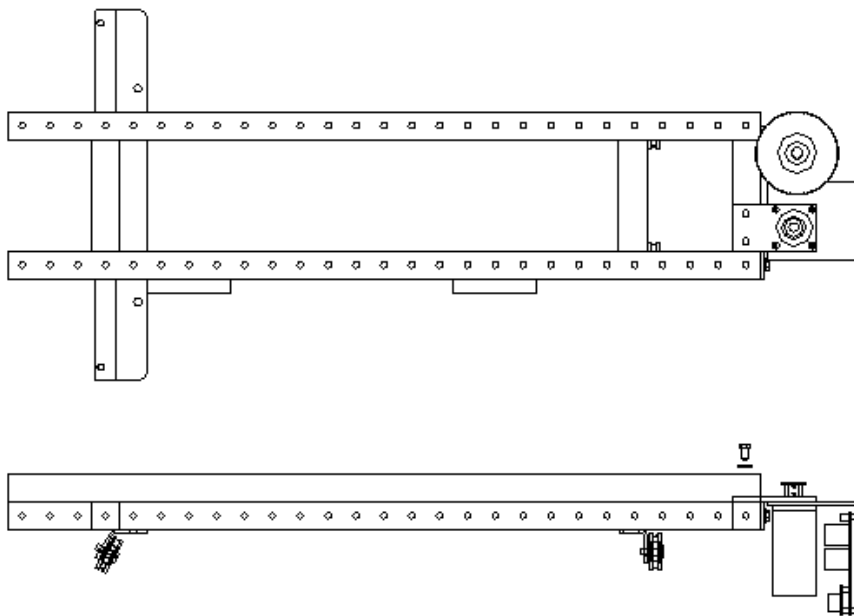

Step 4: Install the black Y-axis main timing belt onto the motor pulley and large drive pulley. Tension the belt by loosening the motor plate screws and pulling the motor away from the large pulley. Tighten the bolts **NOTE: THE BELT SHOULD BE TIGHTENED SO THAT RESISTANCE IS FELT WHEN YOU PRESS ON THE UNSUPPORTED SECTION OF THE BELT.**

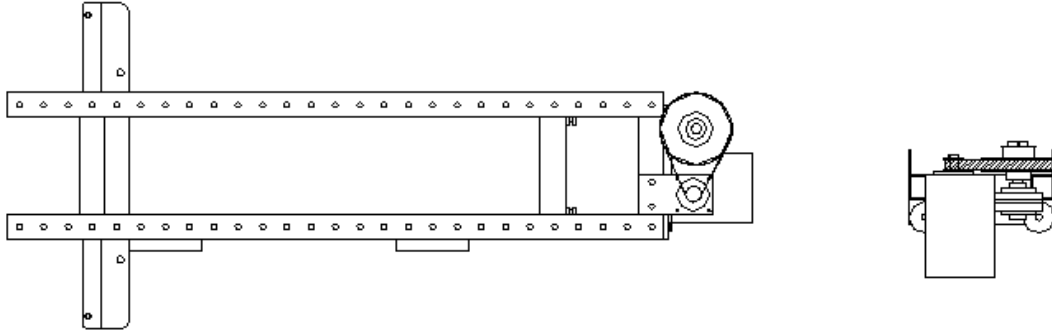

Step 5: Install the Y-axis idler pulley onto the inside of the right carriage rail directly in front of the lower carriage rear wheel assembly using (2) 5/16 x 2-3/4" hex head bolt, (4) flat washers and (2) nylon insert lock nuts.

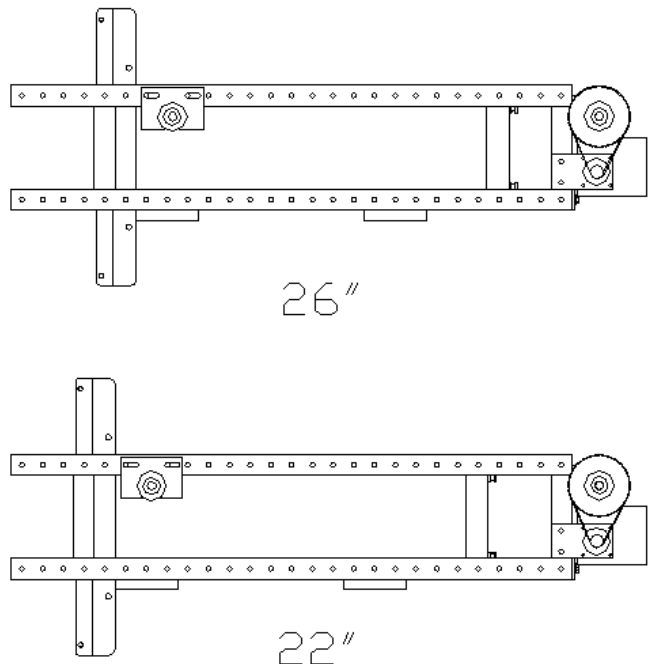

Step 6: Install the Y-axis quick disconnect clamp onto right front wheel beam of the Innova using (2) 8-32 x 1/2" socket head bolts and (2) 8-32 t-nuts. See the diagram below for correct orientation.

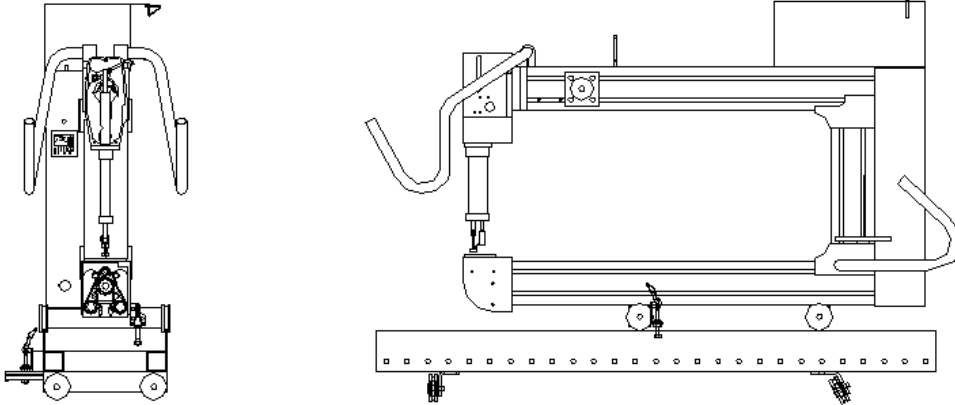

Step 7: Install the Y-axis timing belt clamp plate onto the quick disconnect clamp. Be sure to follow the orientation in the diagram below.

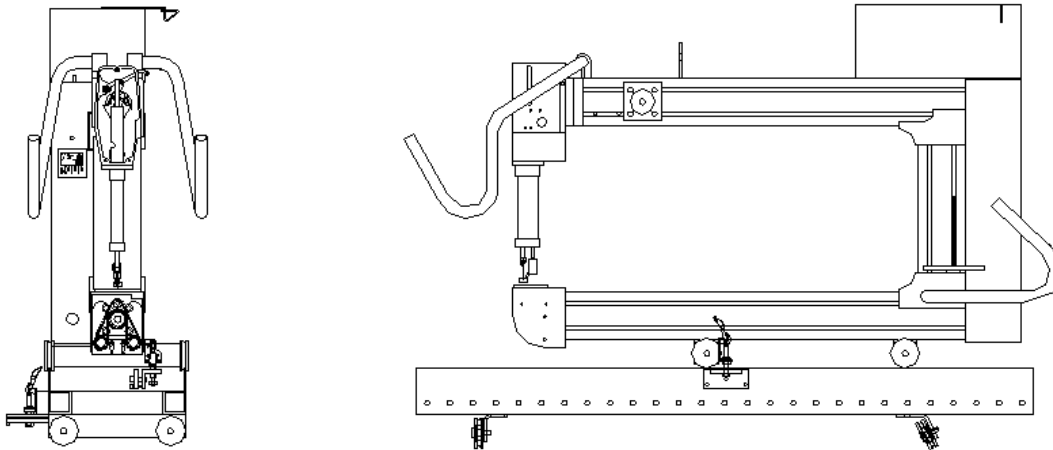

Step 8: Install the white Y-axis timing belt onto the front medium drive pulley and the rear idler pulley. Install the open ends of the belt as high as possible in the clamp plate and tighten the (2) #8 bolts and the (1) ¼” bolt in the center. **NOTE: THE CLAMP PLATE MUST BE INSTALLED ON THE LEFT SIDE OF THE WHITE TIMING BELT LOOP. TO CHECK FOR PROPER INSTALLATION, THE INNOVA SHOULD MOVE TOWARD THE FRONT WHEN THE LARGE PULLEY IS TURNED COUNTER-CLOCKWISE WHEN VIEWED FACING FROM THE TOP LOOKING DOWN.**

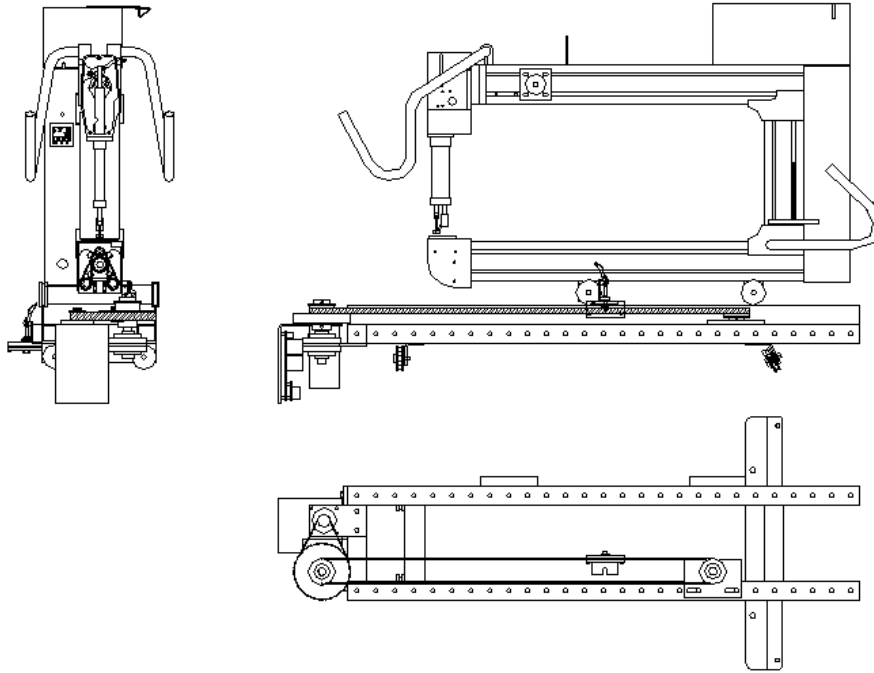

Step 9: Tighten the white belt by pulling the idler pulley assembly toward the rear of the carriage and tightening the (2) hex head bolts.

Step 10: Connect the communication cable and the power cable to the y-axis motor assembly.

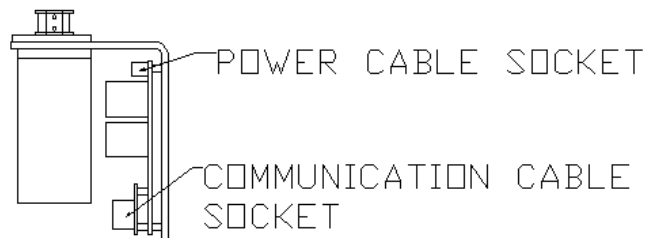

Step 11: Wire tie the communication cable and the power cable to carriage as shown below.

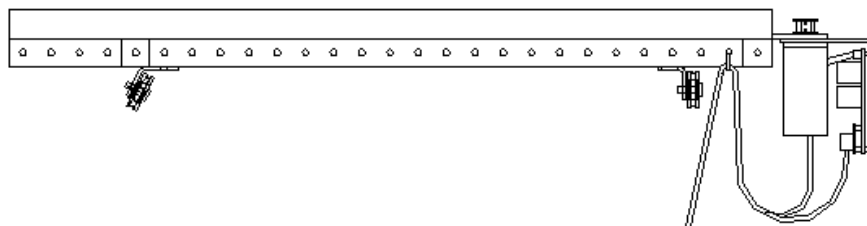

Step 12: Install the Y-axis motor guard onto the front of the lower carriage. Hold the open side of the guard assembly vertically and bring the guard up into the Y-axis motor assembly. Rotate the guard up and over the pulley and motor assemblies and fit the slots onto the bolts. **DO NOT FORCE THE GUARD OVER THE MOTOR ASSEMBLY. TAKE CARE WHEN INSTALLING SO THAT THE MOTOR ASSEMBLY AND CABLING IS NOT DAMAGED.**

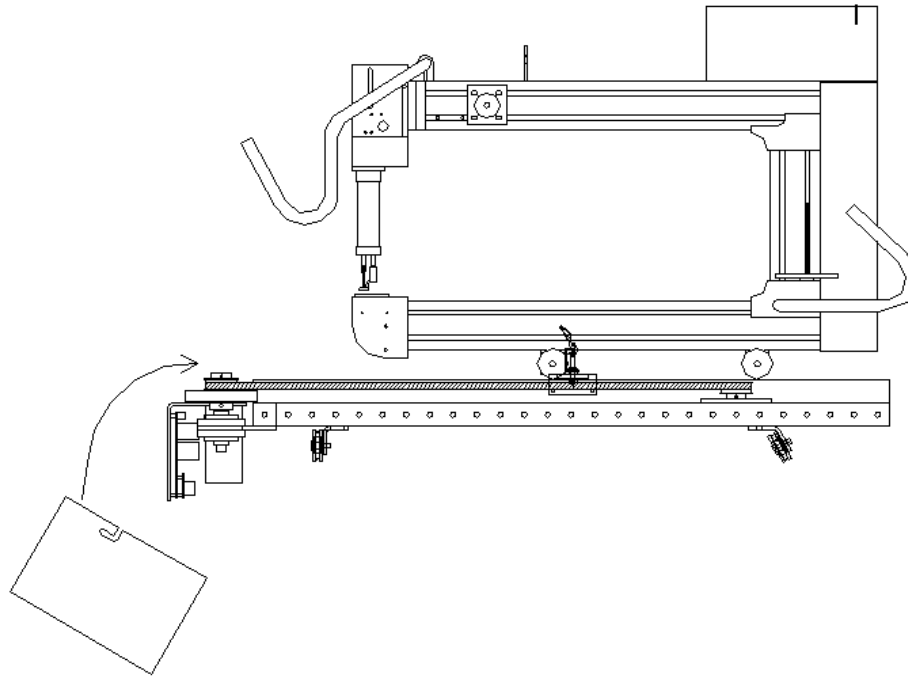

4.0 Wiring

Step 1: Install the tablet mount onto the right front handle bar of the Innova.

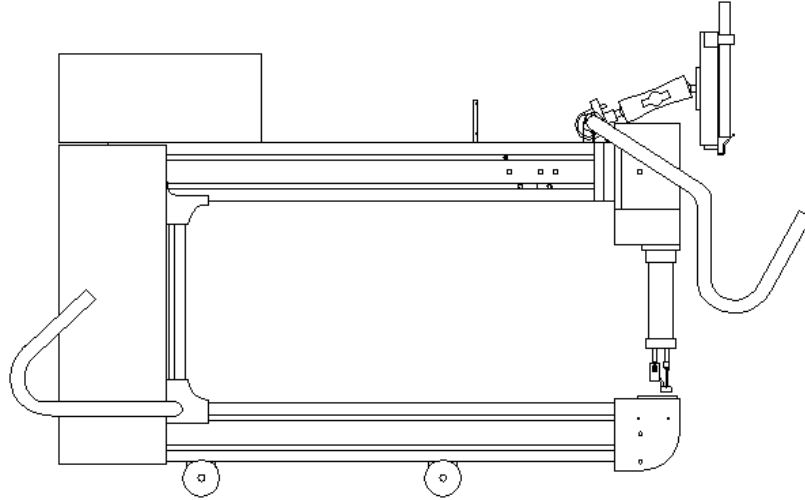

Step 2: Loosen, but do not remove, the (8) screws on the top motor cover and the (7) screws on the rear electronics cover of the Innova. Remove the top motor and rear cover and set aside. Take care not to scratch the covers.

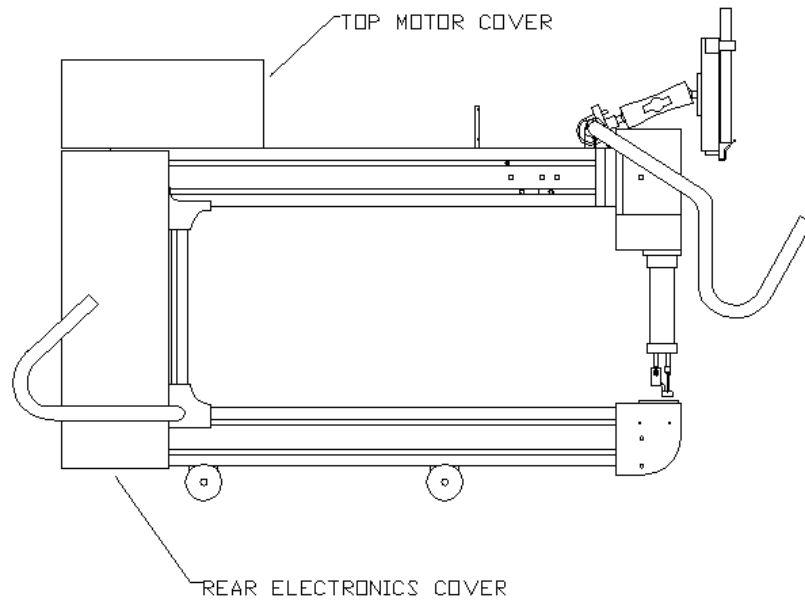

Step 3: **NOTE, THIS STEP IS FOR STANDARD STITCH AND PRO-STITCH REGULATED MACHINES ONLY, SKIP TO STEP 4 FOR LIGHTNING STITCH EQUIPPED MACHINES.** Locate the Innova communication cable and terminal block. If double-sided tape is applied to the terminal block, remove the backing and attach the block in the position noted below. When attaching the terminal block to the machine, be sure that the communication cable is on the left side of the block and the unused, “open” terminals are facing to the right side of the machine. **NOTE: IF DOUBLE-SIDED TAPE IS NOT PROVIDED, PLEASE USE 5-MINUTE EPOXY TO ATTACH THE TERMINAL BLOCK TO THE MACHINE. EPOXY PROVIDES A STRONGER BOND AND IS THE PREFERRED METHOD WHEN NAVIGATORS ARE ASSEMBLED AT THE FACTORY. FOR PACKAGING AND SHIPPING CONCERNS, 5-MINUTE EPOXY IS NOT INCLUDED WITH THE KIT.**

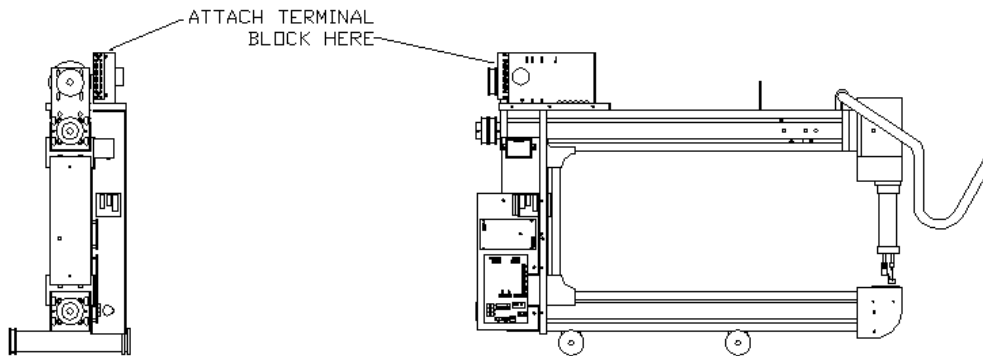

Step 4: Following the wiring diagram provided in the rear of this manual:

FOR STANDARD AND PRO-STITCH REGULATED MACHINES: Connect the labeled terminal block locations to the corresponding PLC green terminals with the provided 18 AWG wire. Additionally, disconnect the (2) black 5-wire stitch regulator encoder cables from the rear of the PLC and connect them to the new gray terminal block. Make sure to connect the encoder that is located at the rear of the lower carriage to the terminals marked X and attach the encoder located in front of the Innova main ON/OFF switch to the terminals labeled Y.

FOR LIGHTNING STITCH MACHINES: If present, remove the terminal block from the communication cable, and wire the cable to the Lightning board as illustrated in the wiring diagrams at the back of the manual.

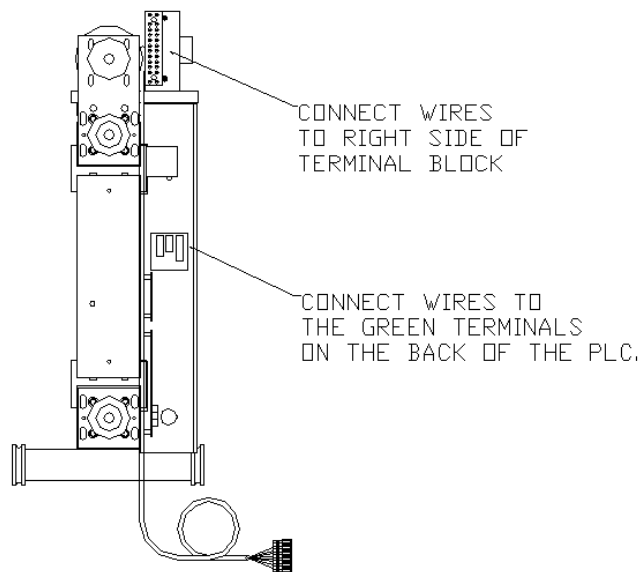

Step 5: Using the provided nylon ties, secure the communication cable and 18 AWG wires to the existing Innova wiring harness. Be sure to route and secure all of the wires so that they do not come in contact with any of the moving pulleys of belts on the machine.

Step 6: Attach (2) wire tie mounts to the lower slot of the upper beam and nylon tie the tablet to Navigator communication cable (USB) to the mounts – make sure that the larger plug end of the cable is facing toward the tablet mount. Route the USB cable through the small gap at the front lower of the Innova electronics area. Nylon tie both of the communication cables to the bottom electronics cover plate. Use at least (2) nylon ties to secure the cable through the same holes to which the encoders and power cable are attached.

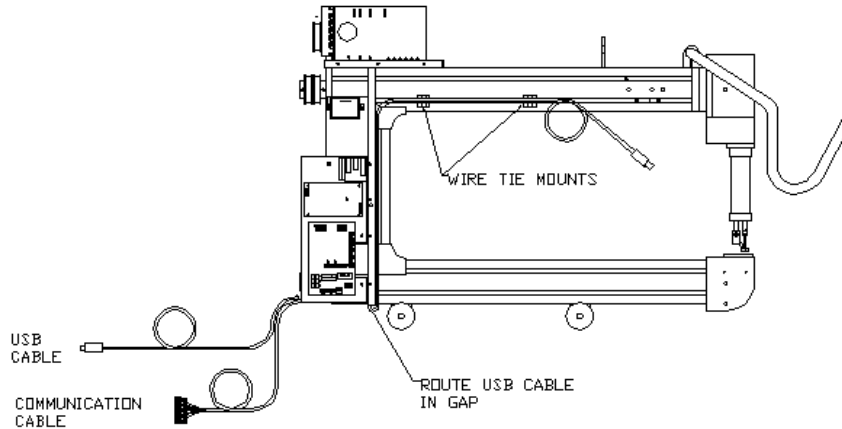

Step 7: Secure the communications cables to the black plastic wire tie mount on the rear of the Innova carriage. Provide enough slack for the machine to move freely and completely from the front to the back.

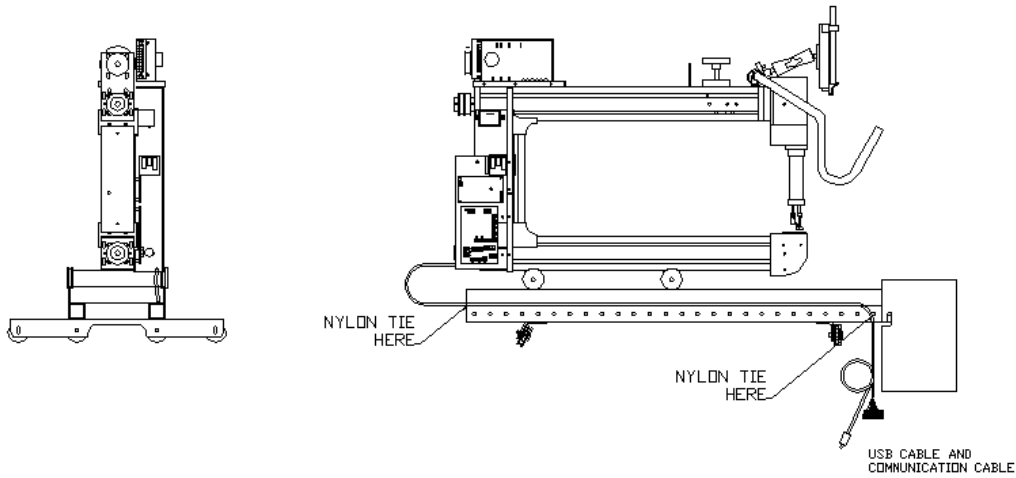

Step 8: **MAKE A CHOICE:**

CABLES LOCATED AT THE REAR OF THE MACHINE: Wire tie the communications cables to the power cord.

CABLES LOCATED UNDER THE QUILT AT THE FRONT OF THE MACHINE: Route and wire tie the communications cables along the inside to the lower carriage rail and the front of the carriage underneath the Y-axis motor guard. Make sure the communication cable does not rub on the pulleys and belts located at the front of the carriage. Nylon tie the cables to the holes of the carriage.

Step 9: Remove the front cover of the pushbutton station and install it onto the lifting bar beam either at the right or left end.

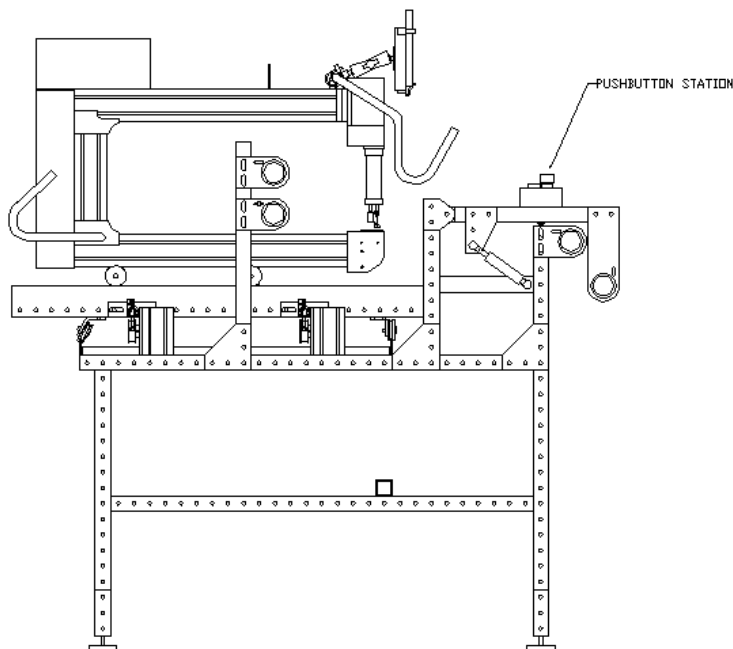

Step 9: Install the controller onto the lower cross beam of the center frame leg assembly as close to the back leg of the frame as possible. Position the controller so that the sockets face towards the front of the machine. Use (2) 10-32 x 2" bolts, (2) flat washers and (2) nylon insert lock nuts.

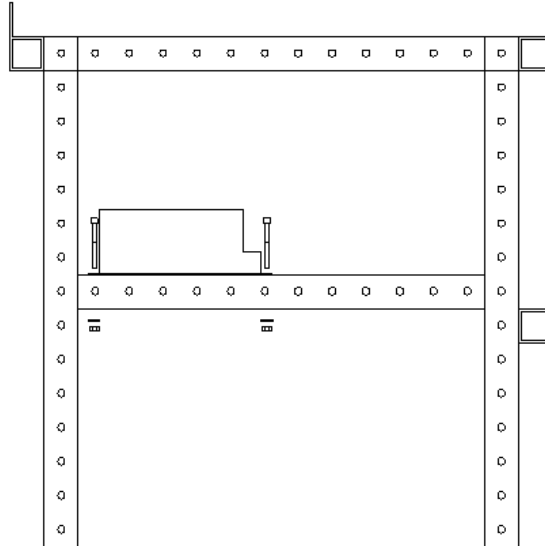

Step 10: Install the motor power supply onto the side of the lower cross beam of the center frame leg assembly. Position the supply so that the cables face towards the controller. Use (2) 10-32 x 2" bolts, (2) flat washers and (2) nylon insert lock nuts.

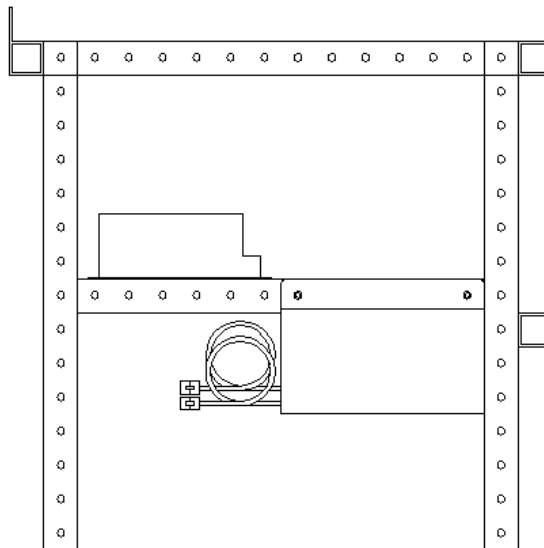

Step 11: Familiarize yourself with the terminals located on the top and front of the control box.

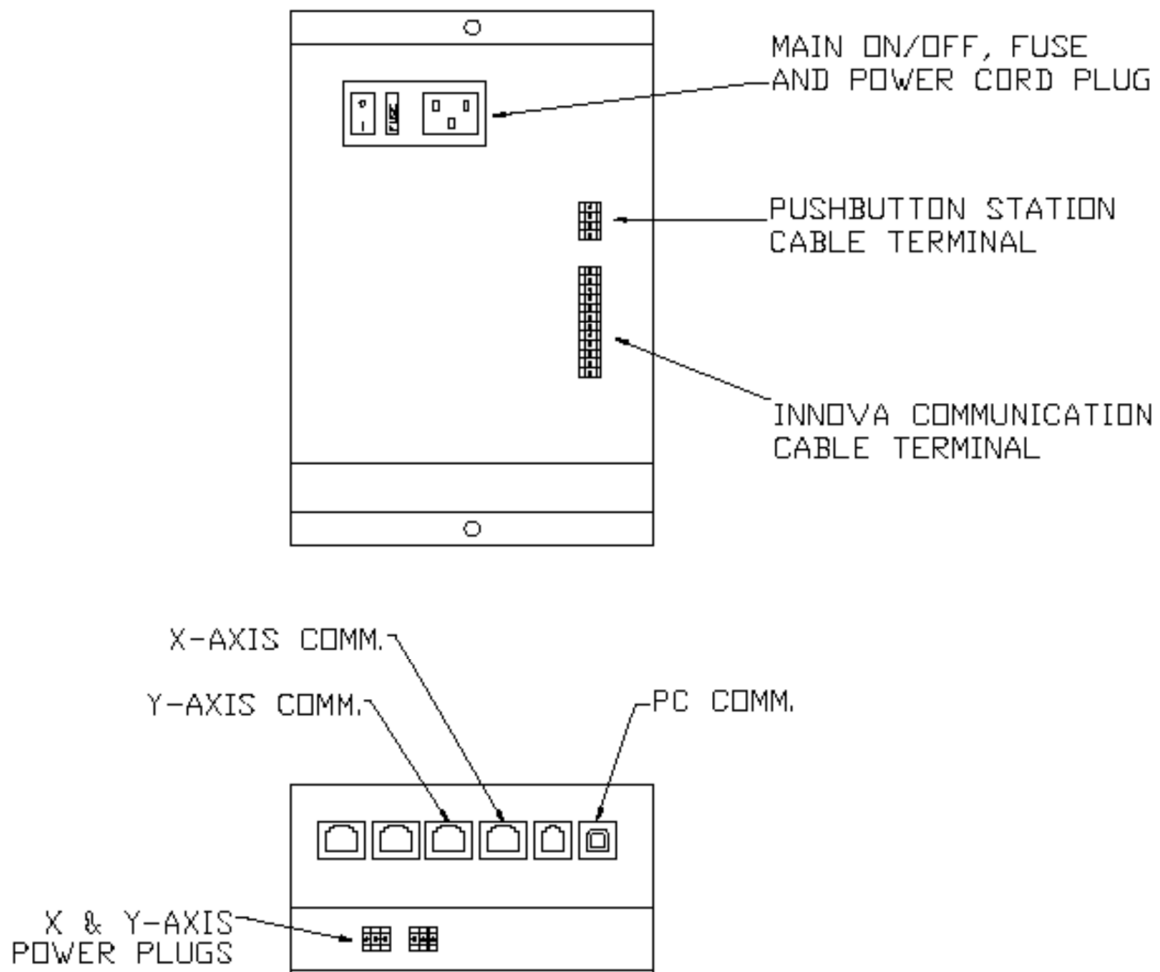

Step 12: Connect the power cord to the corresponding terminal.

Step 13: Connect the motor power supply plug to either the X or the Y drive power plug of the controller.

Step 14: Connect the Innova and Tablet communications cables to the controller.

Step 15: Connect the pushbutton station cable to the controller

Step 16: Connect the X and Y-axis communication cables to the controller.

Step 17: Confirm that the machine has a free range of motion and is not limited by any cables. Adjust the length of or re-route the cables if necessary.

Step 18: Coil up and secure any excess cabling to the frame using the provided wire ties. **NOTE: FAILURE TO DO SO MAY CAUSE A TRIPPING HAZARD AND/OR MACHINE DAMAGE.**

Step 19: Connect the PC and the Navigator transformer power cords to the wall outlet. Please note that if the unit is to be used in a 220V single phase power outlet, the motor power supply will have to manually switched to accept the incoming voltage. **FAILURE TO MANUALLY SWITCH THE POWER SUPPLY WILL CAUSE IMMEDIATE FAILURE AND WILL NOT BE COVERED UNDER ANY ABM WARRANTY.**

6.0 18" Navigator assembly modifications

SECTION 2.0 MODIFICATIONS FOR 18" ASSEMBLY

Step 2: **SEE SECTION 6.0 FOR 18" MACHINES.** Install the 15" X-axis t-slotted beam onto the right side of the frame in the eleventh hole of the top frame beam from the rear of the machine. Use (2) 5/16 x 2" HEX bolts, (2) flat washers and (2) 5/16 T-nuts.

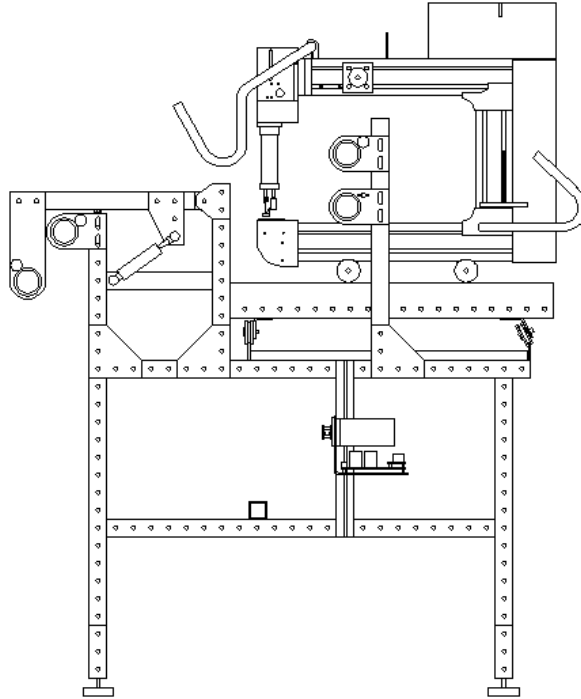

Step 3: Reverse the 5 hole gusset plate on the right side of the frame as illustrated below. Install the X-axis drive shaft assembly onto the right side of the frame. Attach the bearing assemblies at the 5th and 6th and 14th and 15th hole, from the back of the top side tube. Bolt the bearing assemblies using (4) 5/16 x 2" HEX bolts and (4) flat washers from the bottom up.

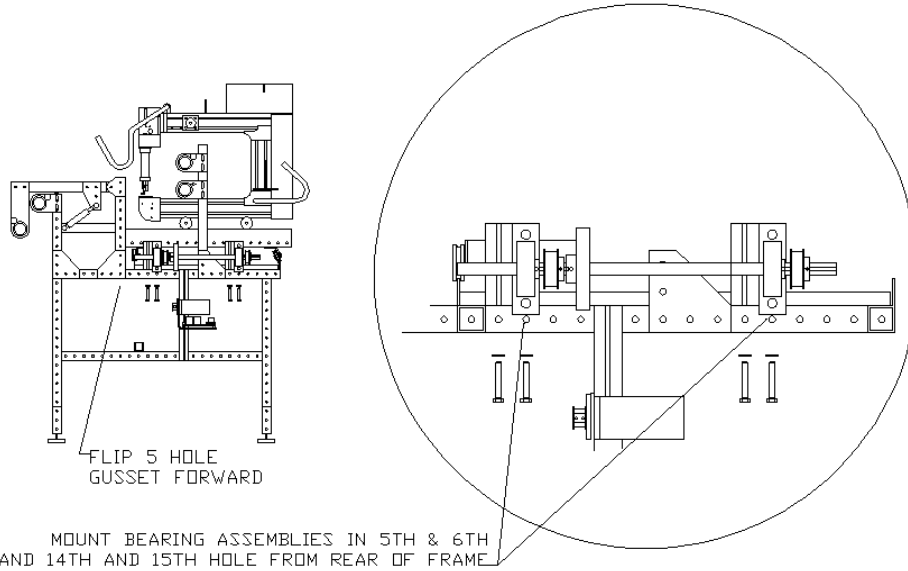

Step 5: Reverse one of the X-axis idler bearing assemblies to look like the assembly on the right in the magnified view. Install the (2) X-axis idler bearing assemblies with guards into the 5th and 6th holes for the rear assembly and the 11th and 12th hole for the front assembly counting from the rear of the left side of the frame. Use (4) 5/16 x 2" HEX bolts and (4) flat washers.

