

INNOVA PART DIAGRAMS

TABLE OF CONTENTS:

A – SEWING HEAD STRUCTURAL ASSEMBLY	L2 – SHEETMETAL AND COVER (CURRENT VER.)
B1- UPPER AND LOWER SHAFTING (ORIGINAL VER.)	M1 – THREAD STAND (ORIGINAL VER.)
B2 – UPPER AND LOWER SHAFTING (CURRENT VER.)	M2 – THREAD STAND (CURRENT VER.)
C – UPPER SEWING NEEDLE MECHANISM	N1 – FRONT HANDLE BAR ASSEMBLY
D1 – LOWER SEWING HOOK MECHANISM (ORIG. BELT VER.)	O1 – REAR HANDLE BAR ASSEMBLY (ORIGINAL VER.)
D2 – LOWER SEWING HOOK MECHANISM (CURRENT VER.)	O2 – REAR HANDLE BAR ASSEMBLY (CURRENT VER.)
E1 – HANDWHEEL (TOP MOUNTED)	P1 – FLUORESCENT LIGHT
E2 – HANDWHEEL (SIDE MOUNTED)	Q1 – LASER ASSEMBLY (ORIGINAL VER.)
F1 – REAR BELT TENSIONER (ORIGINAL VER.)	Q2 – LASER ASSEMBLY (CURRENT VER.)
F2 – REAR BELT TENSIONER (CURRENT VER.)	R1 – ELECTRONICS BACK PLATE
G1 – ROTATING HEAD RELEASE MECHANISM (ORIG.)	S1 – PLC AND SWITCHES
G2 – ROTATING HEAD RELEASE MECHANISM (CURRENT)	T1 – STANDARD STITCH ELECTRONICS
H – RULER PLATE ASSEMBLY	T2 – STANDARD STITCH ELECTRONIC WIRING HARNESSSES
I1 – TENSION ASSEMBLIES (ORIGINAL VER.)	U1 – STANDARD STITCH MOTOR ASSEMBLY
I2 – TENSION ASSEMBLIES (CURRENT VER.)	V1 - INNOVA WHEEL ASSEMBLY
J1 – UPPER REAR THREAD GUIDE (ORIGINAL VER.)	W1 – Y-AXIS ENCODER ASSEMBLY
J2 – UPPER REAR THREAD GUIDE (CURRENT VER.)	X1 – X-AXIS ENCODER ASSEMBLY
K2 – THREAD GUIDES	Y1 – PRO-TOUCHSCREEN
L1 – SHEETMETAL AND COVERS (ORIGINAL VER.)	Y2 – LIGHTNING TOUCHSCREEN
	Z1 – LIGHTNING MOTOR AND CONTROLLER

PLATE A

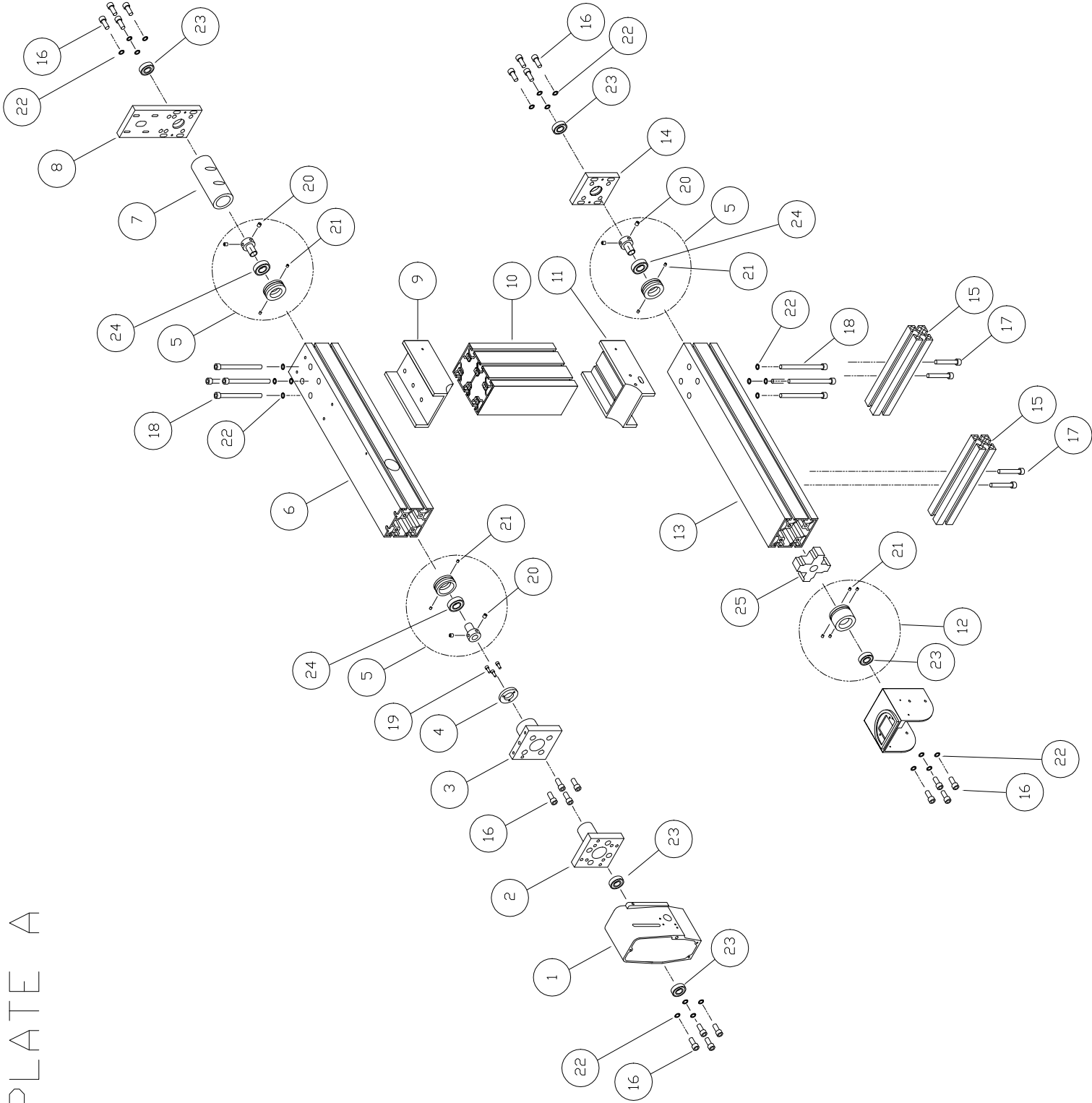

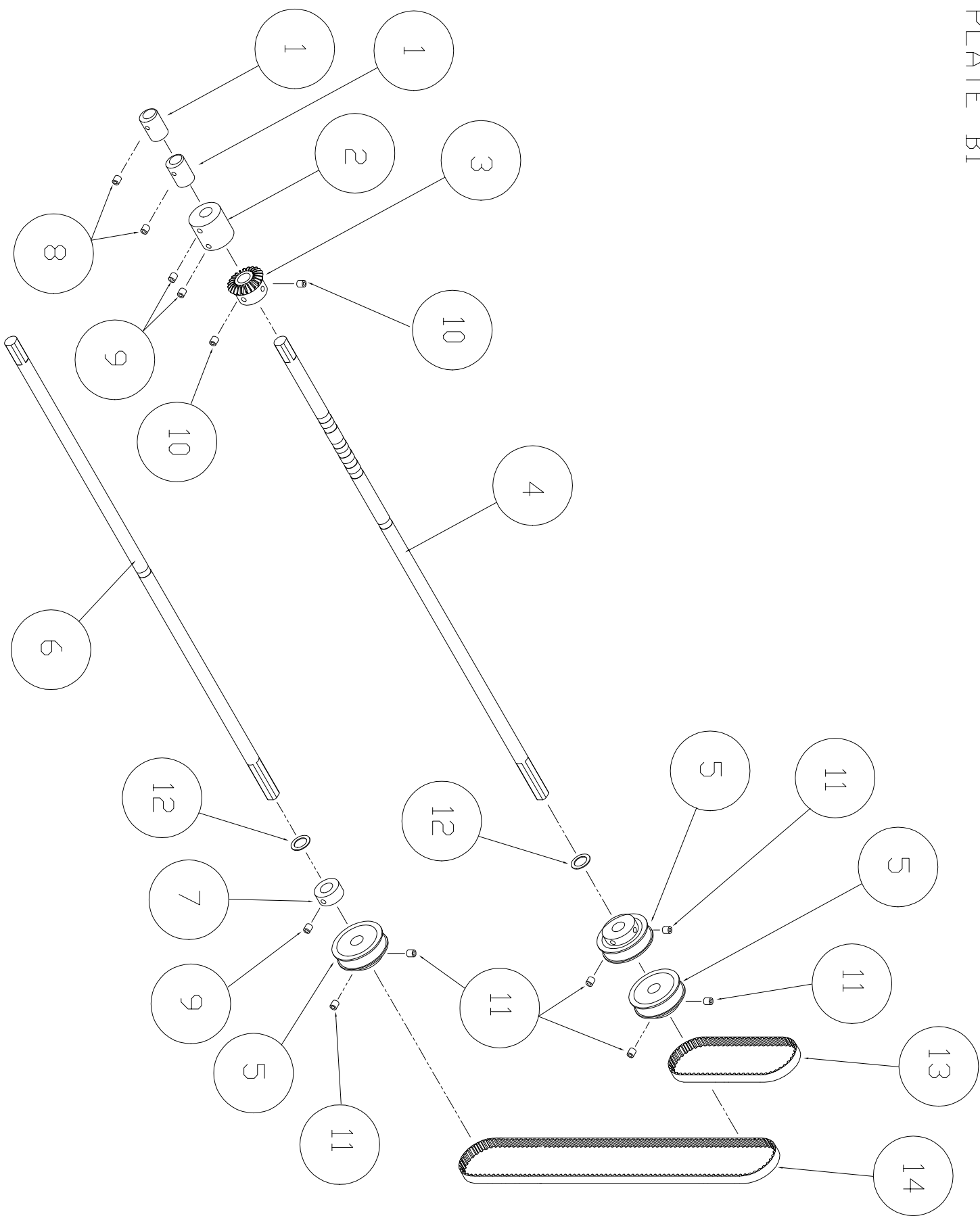

PLATE B2

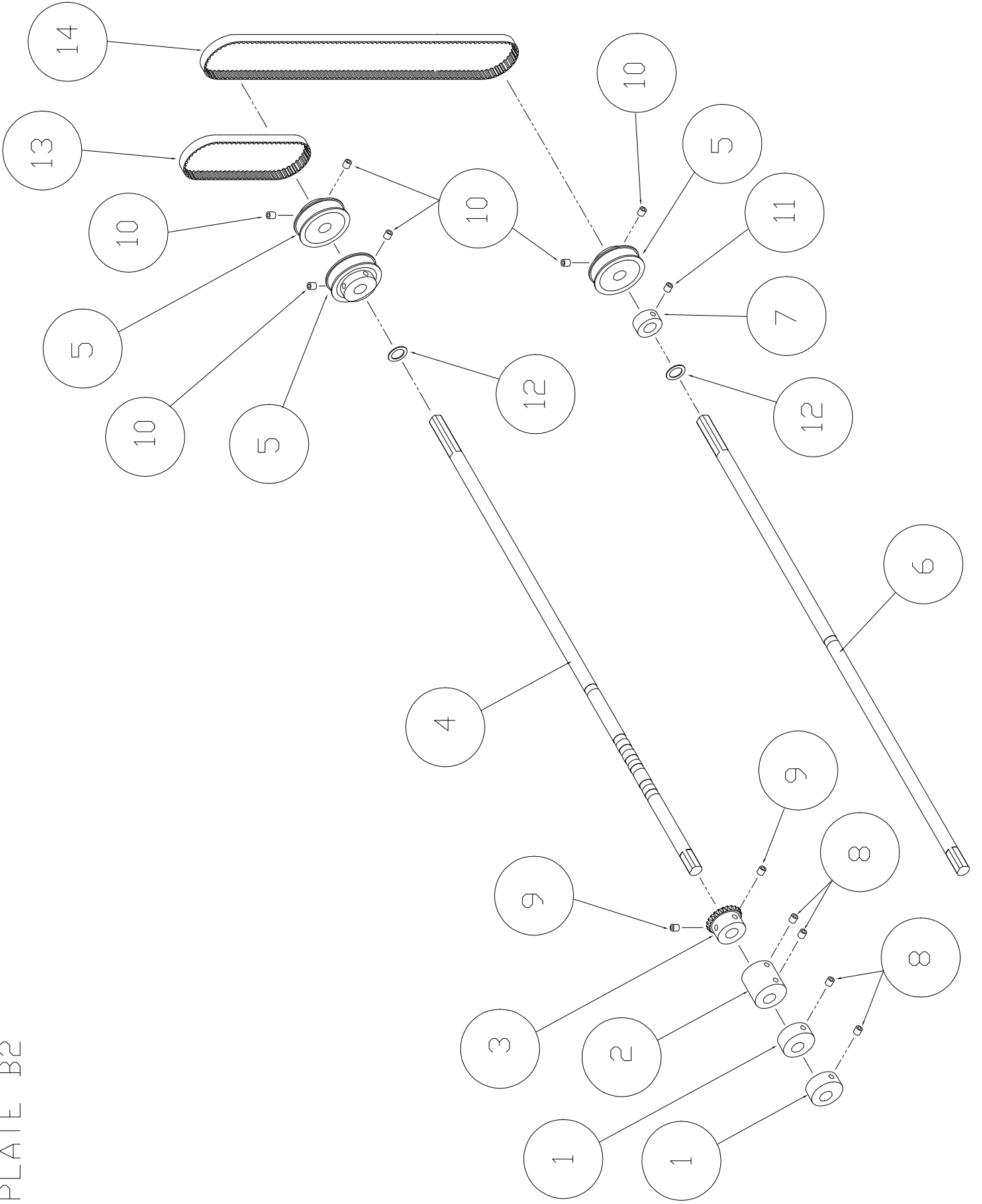

PLATE C

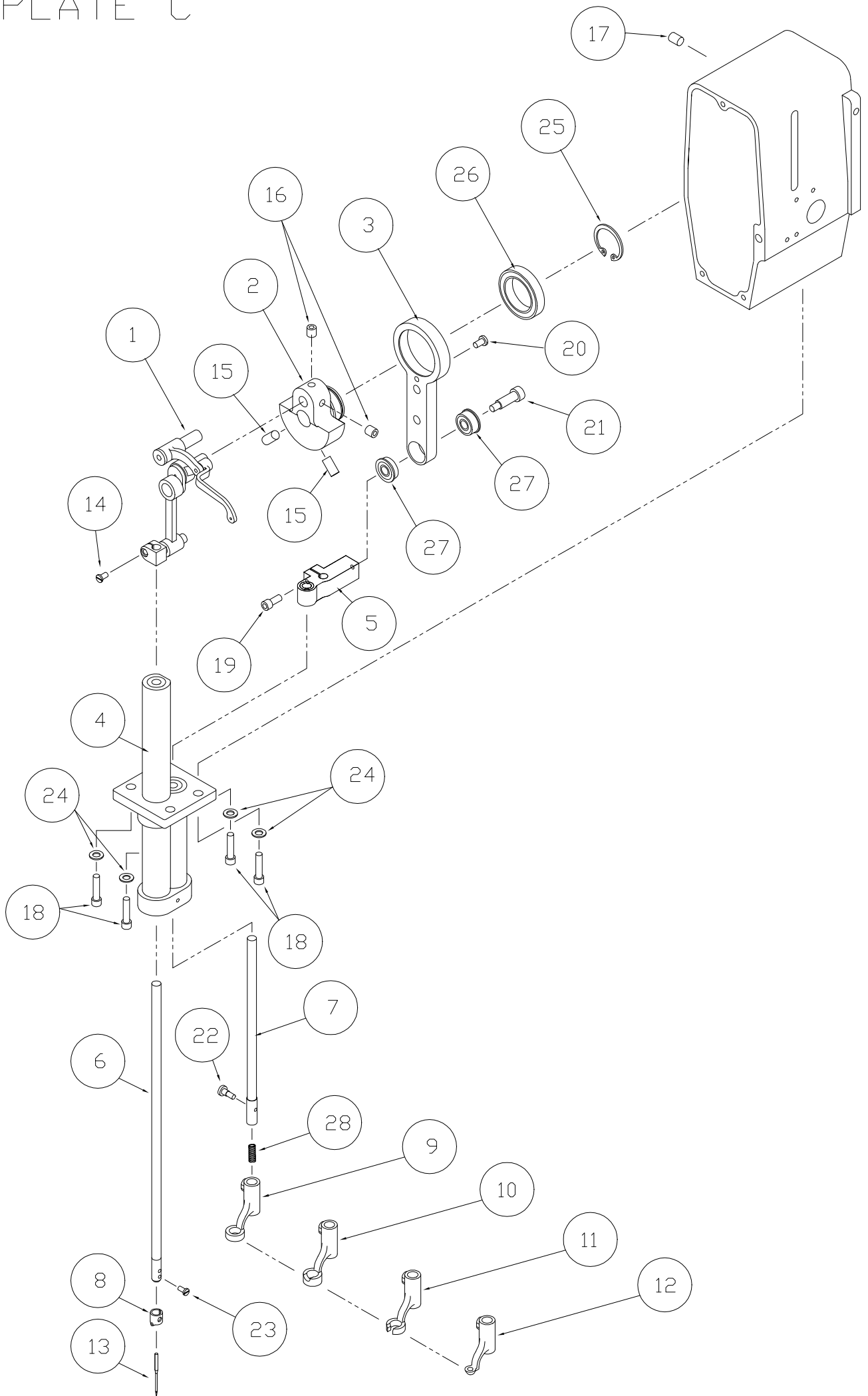

PLATE D1

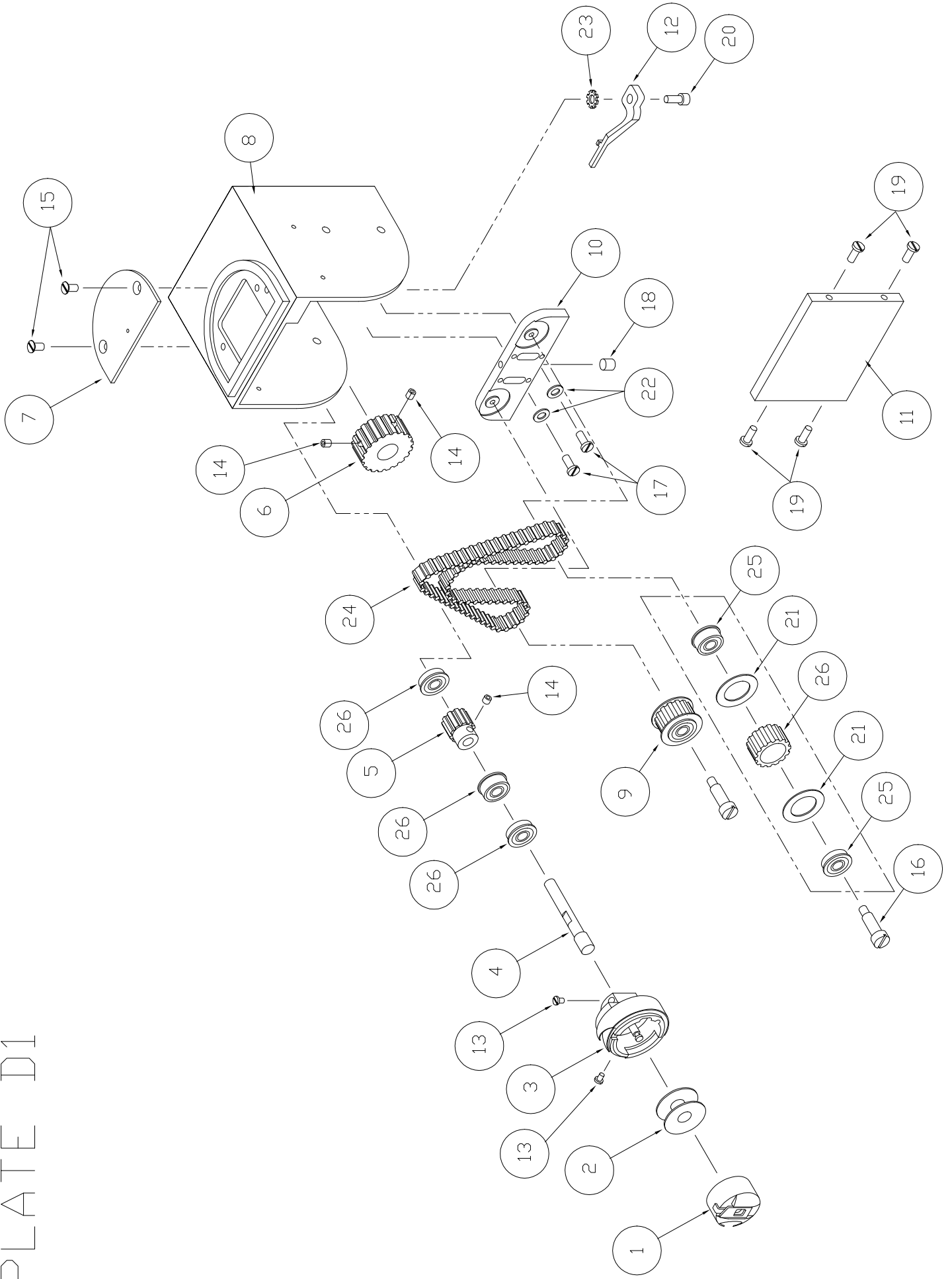

PLATE D2

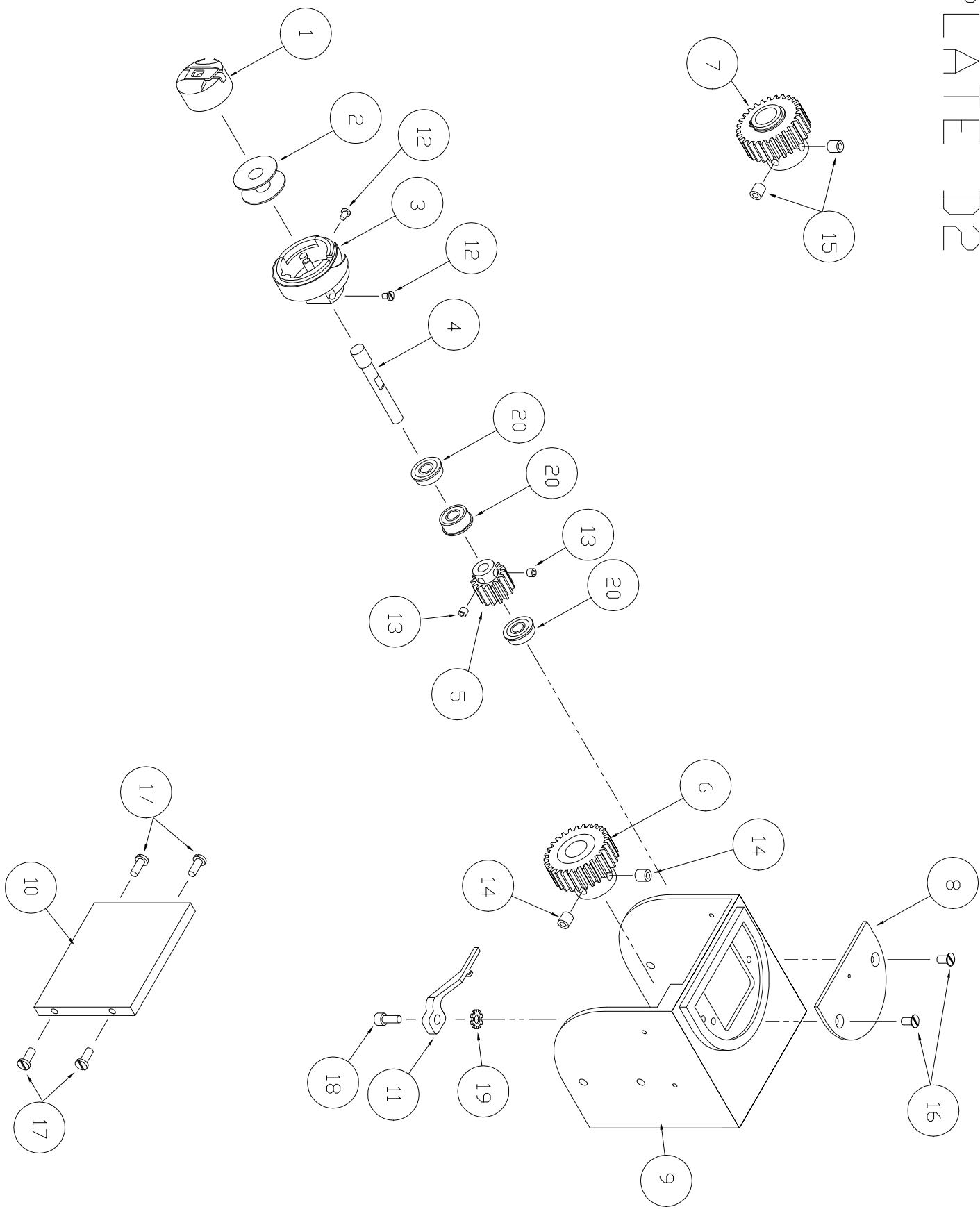

PLATE E1

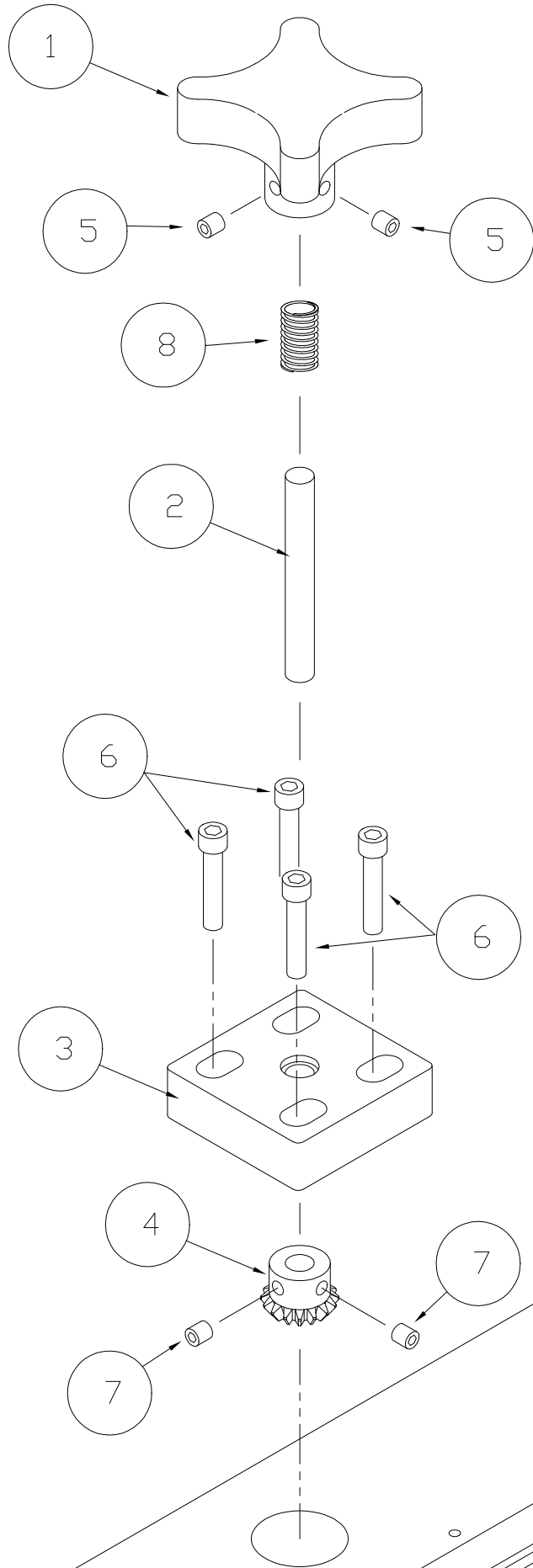

PLATE E2

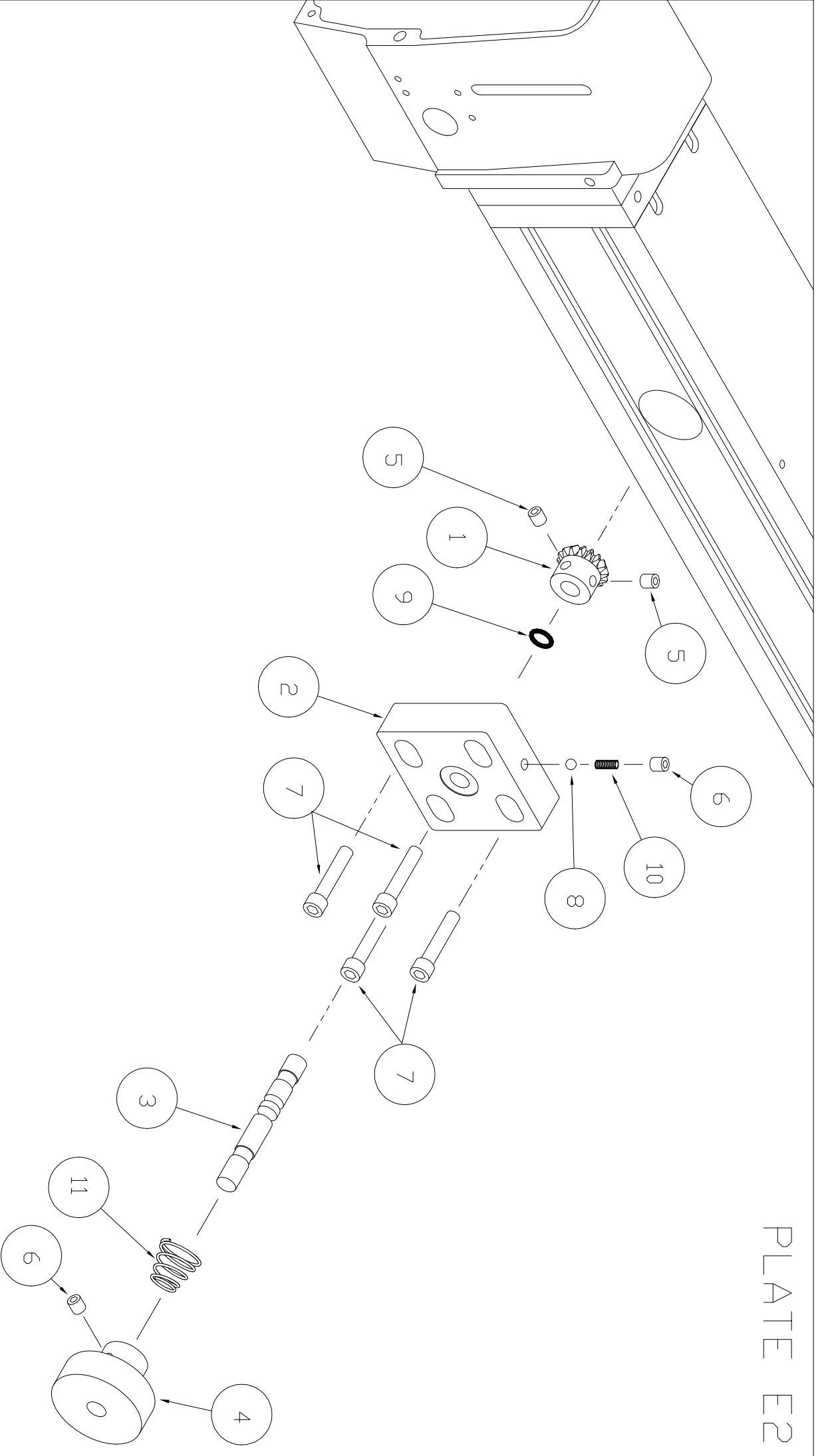
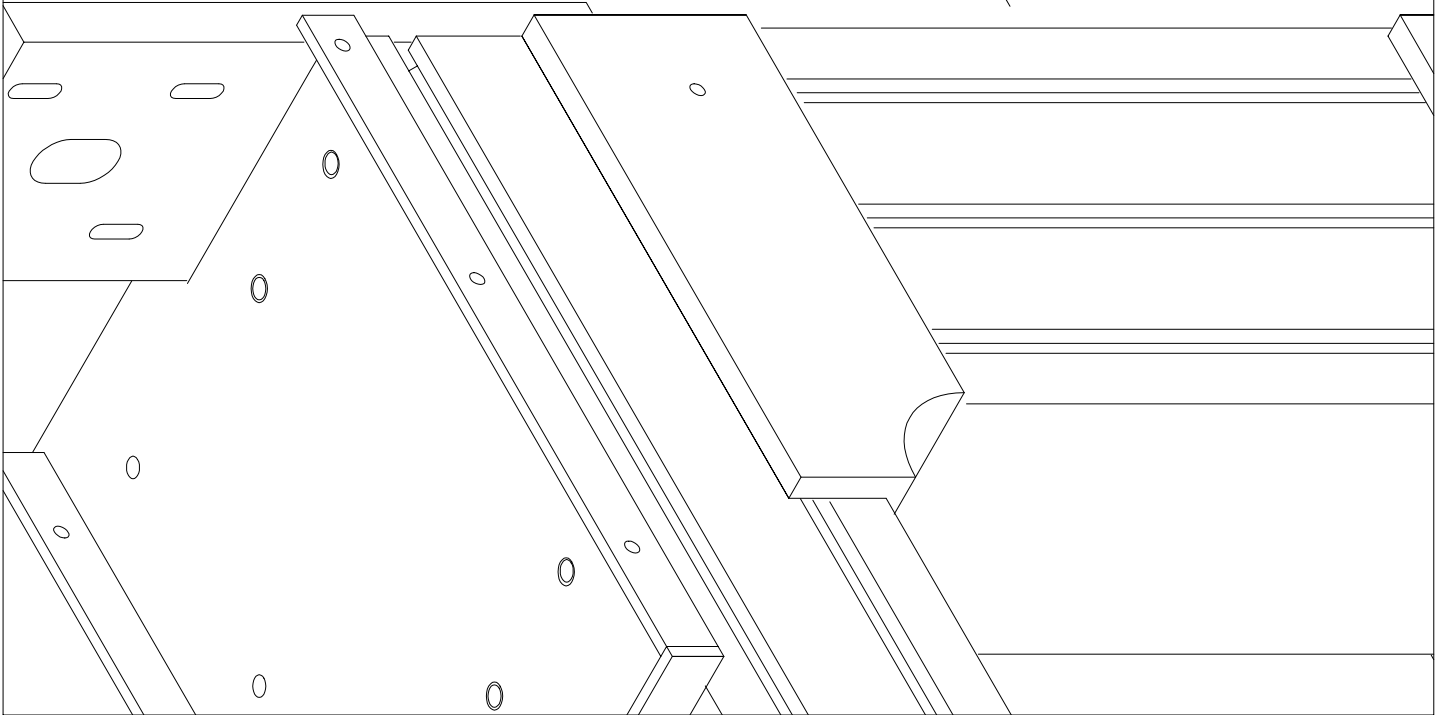
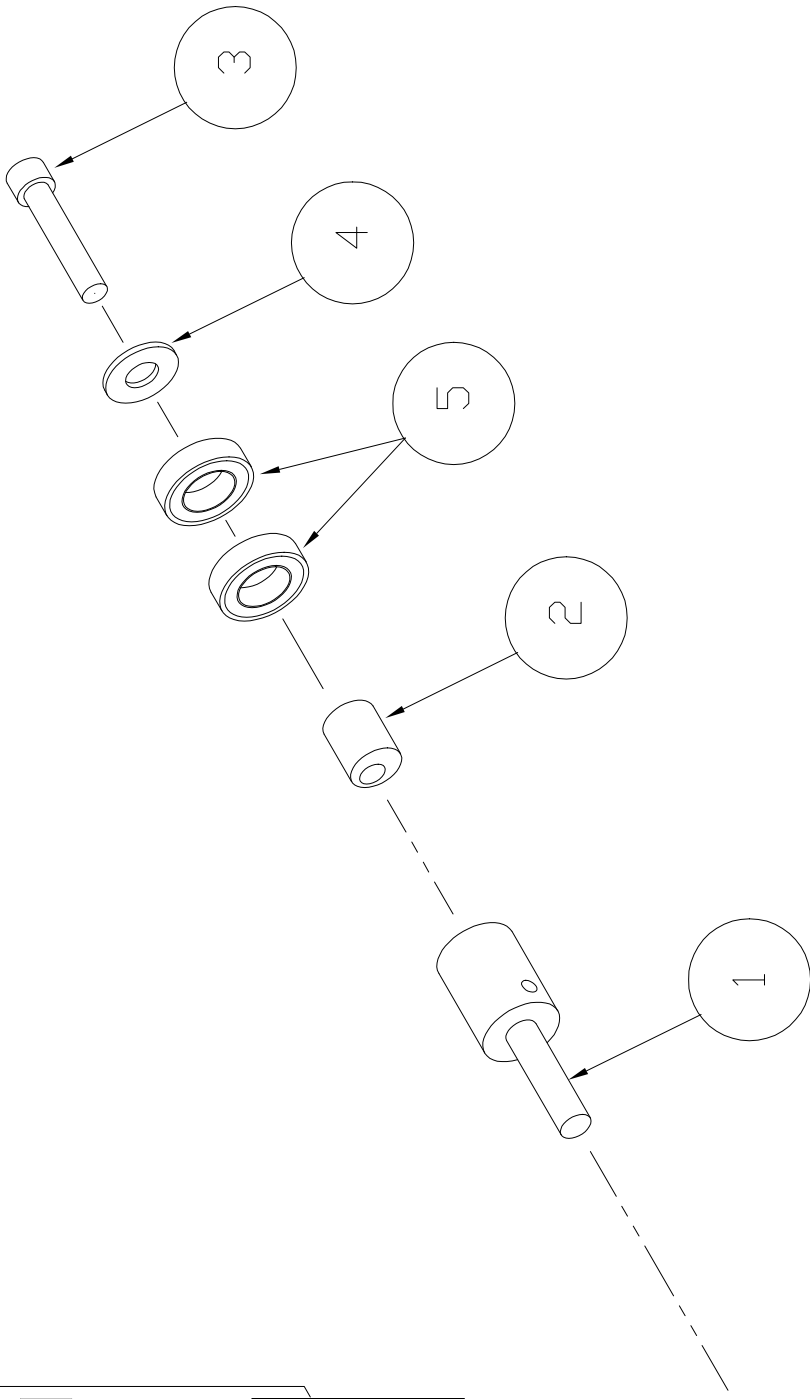

PLATE F1



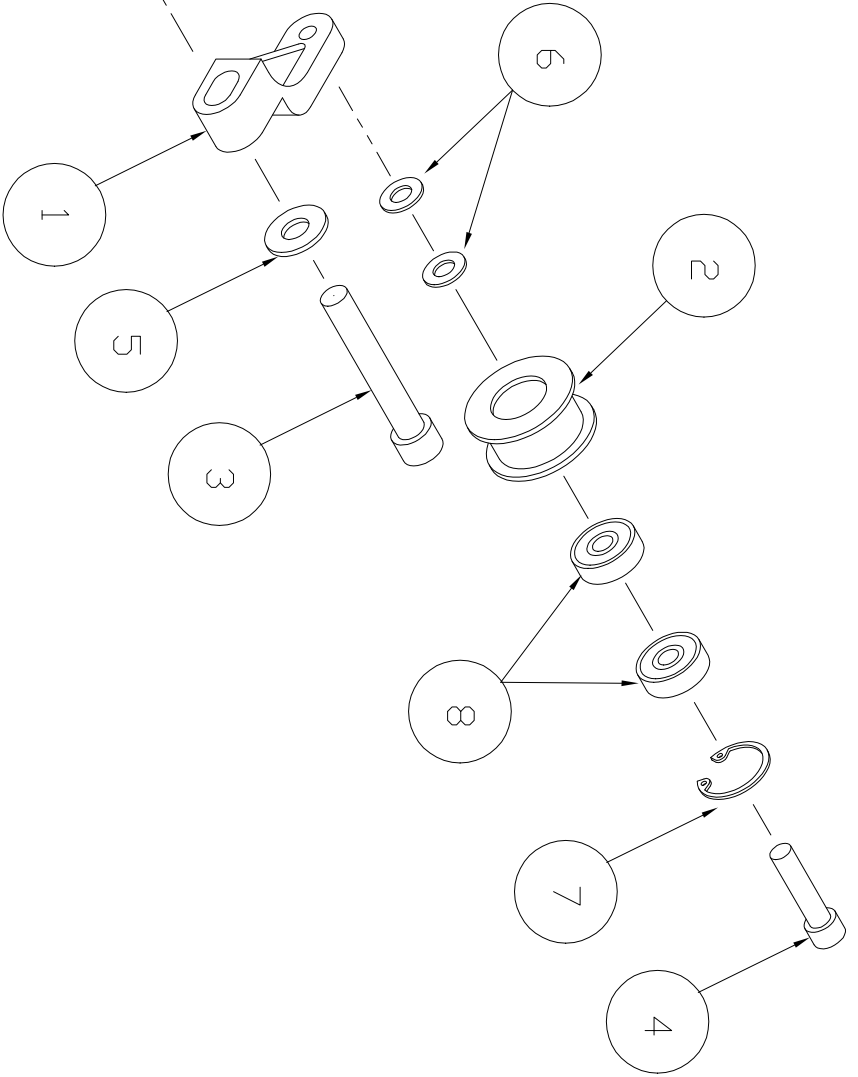
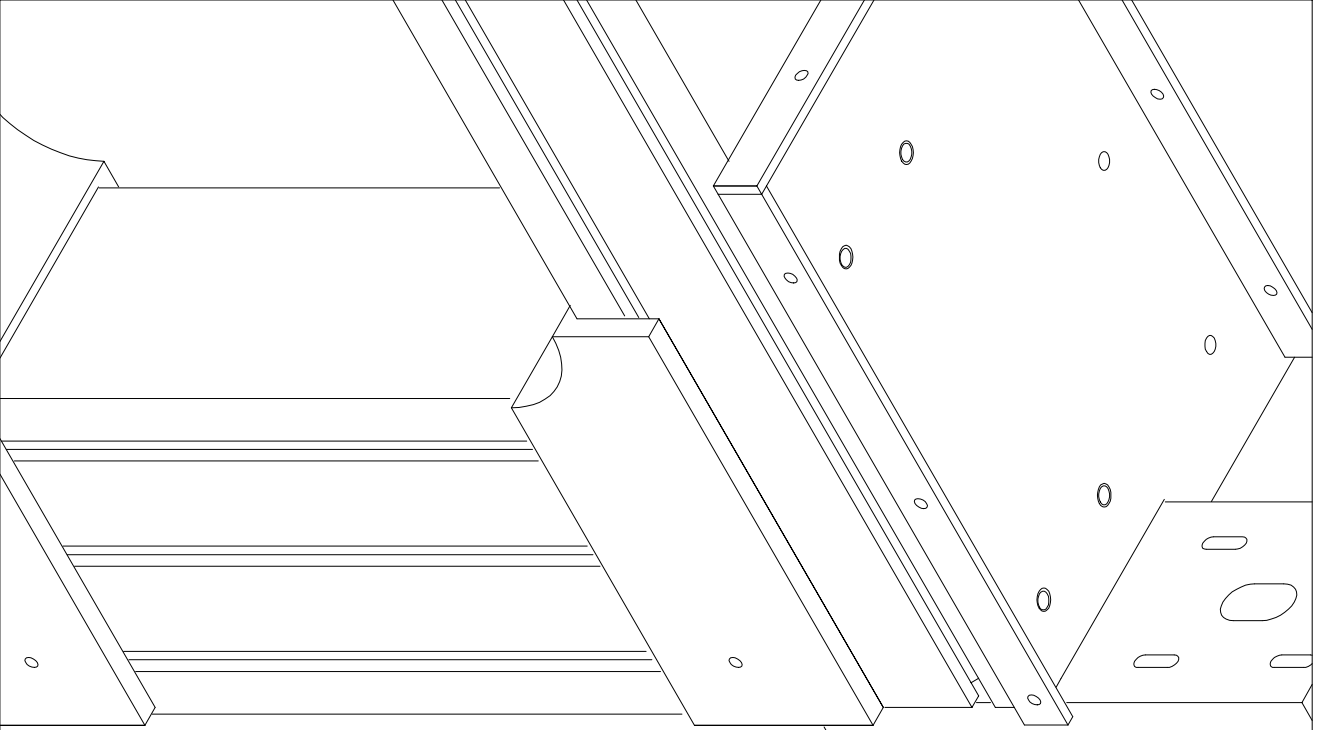

PLATE F2

PLATE G1

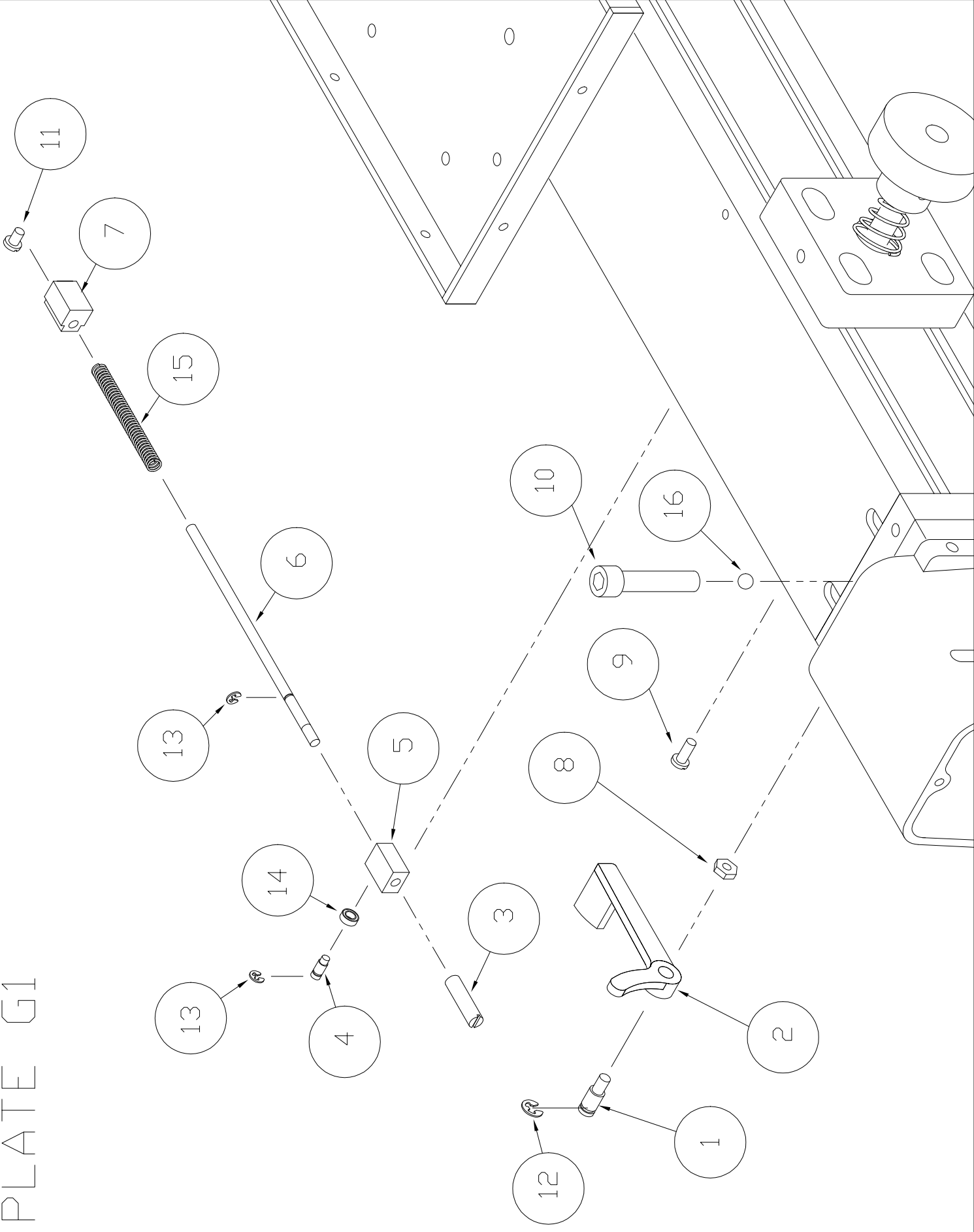

PLATE G2

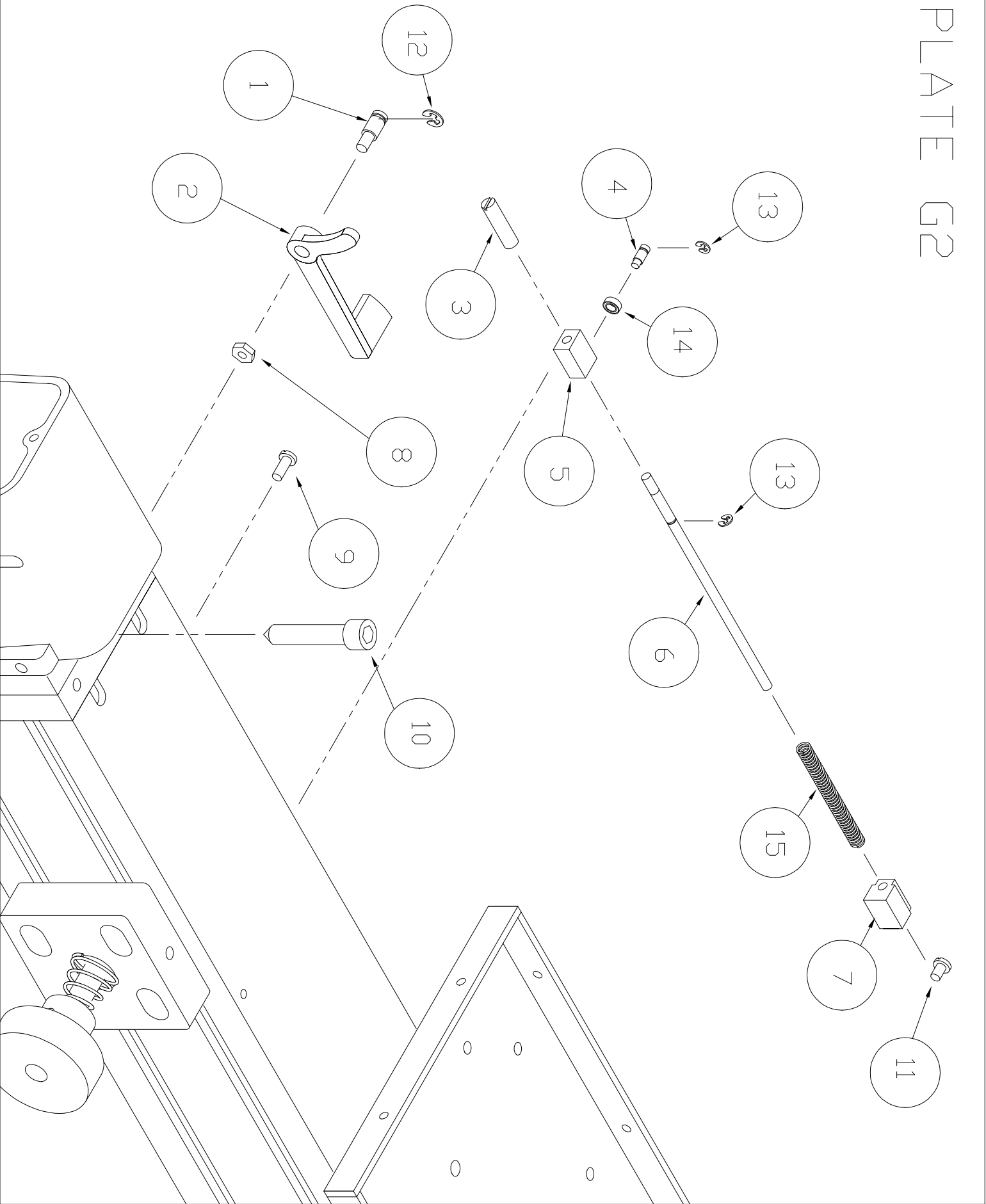
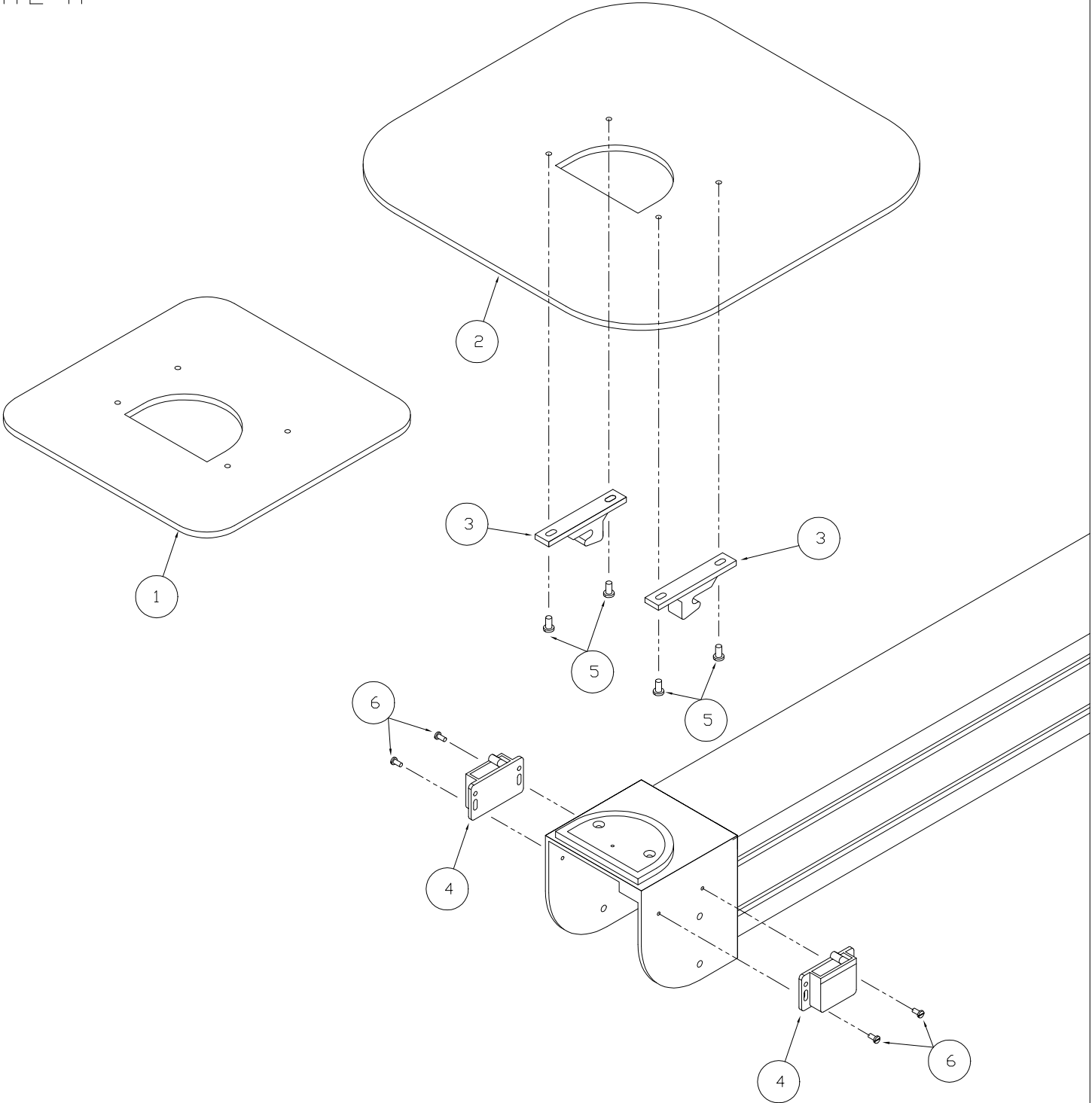

PLATE H



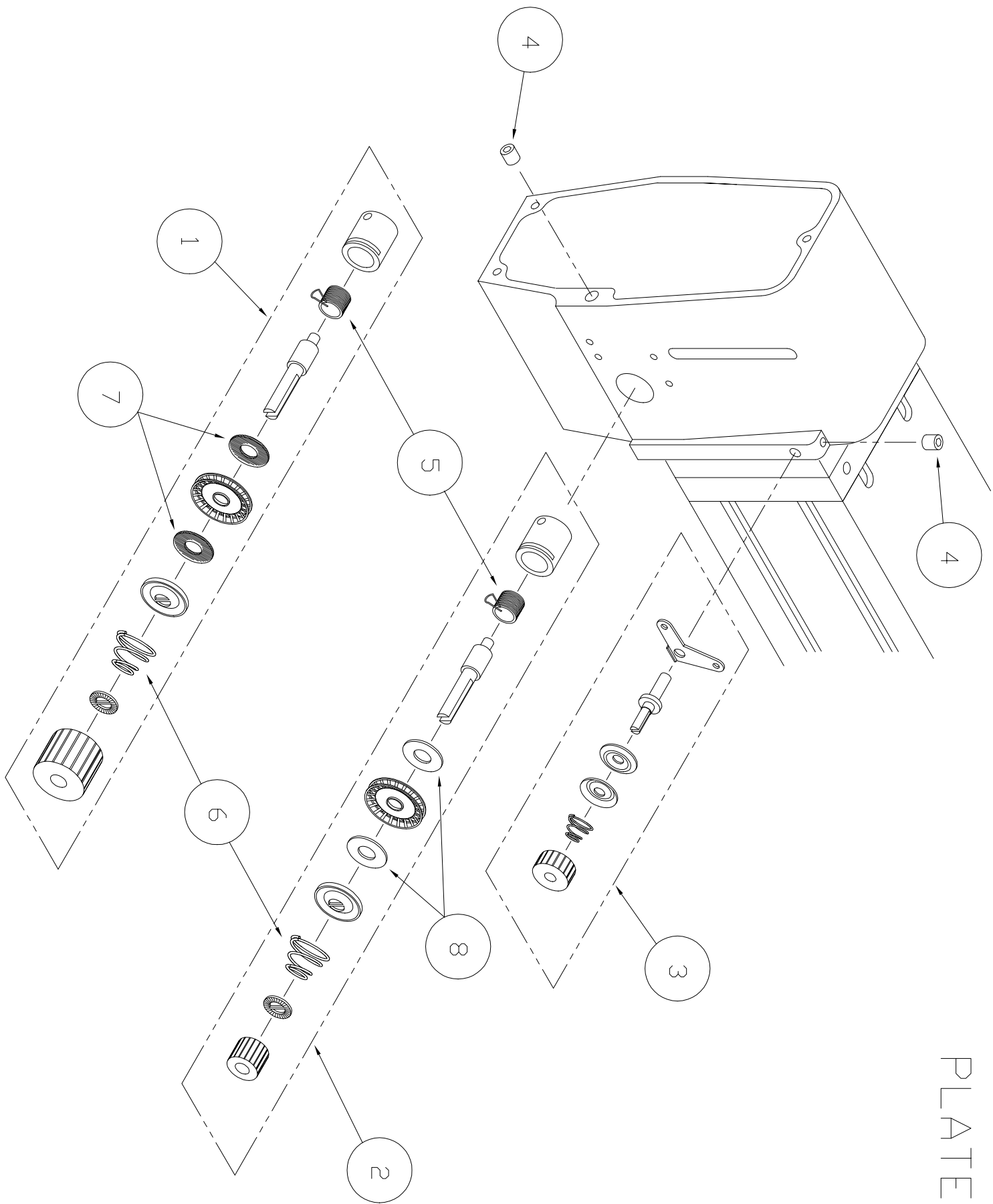

PLATE 12

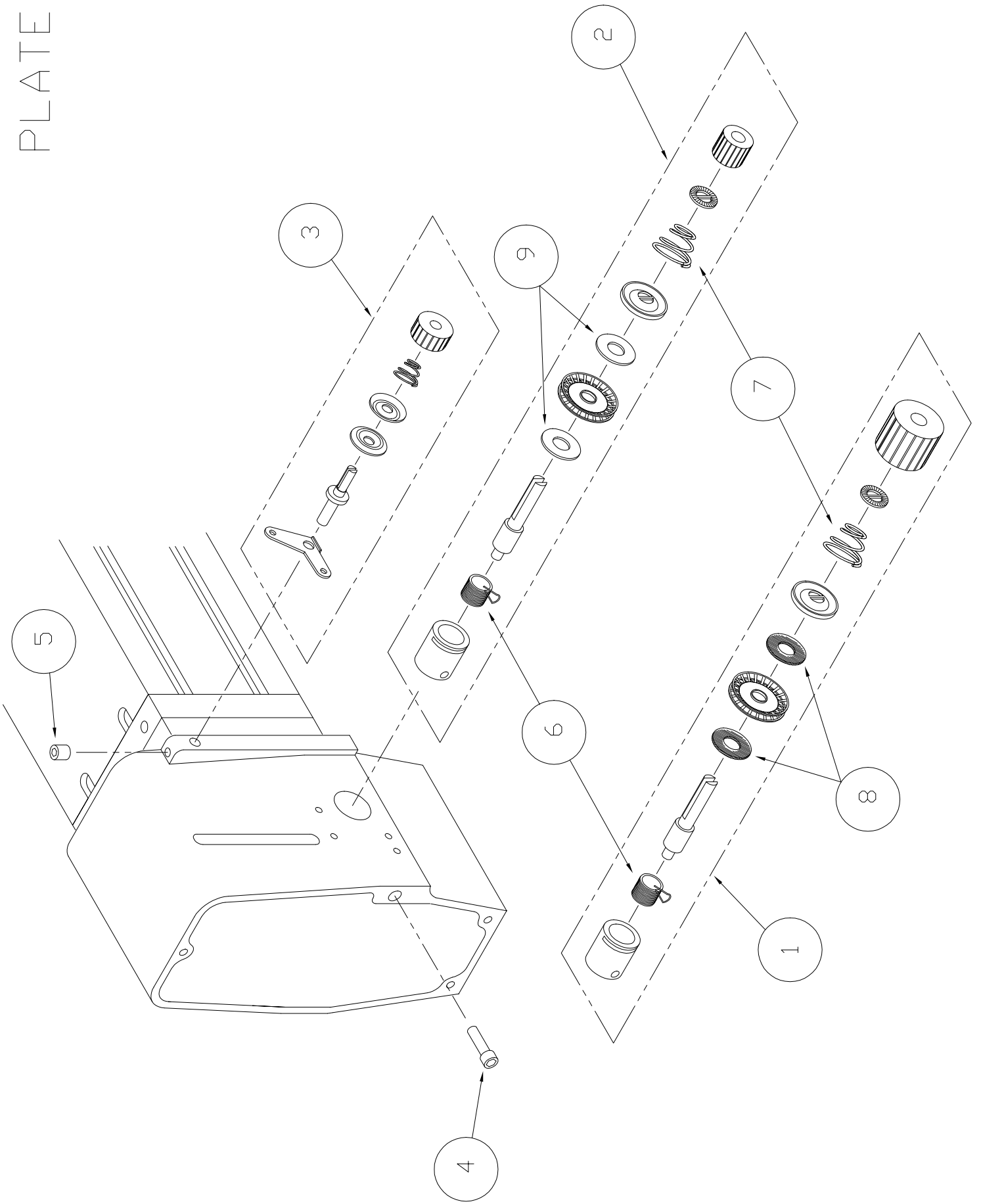

PLATE J1

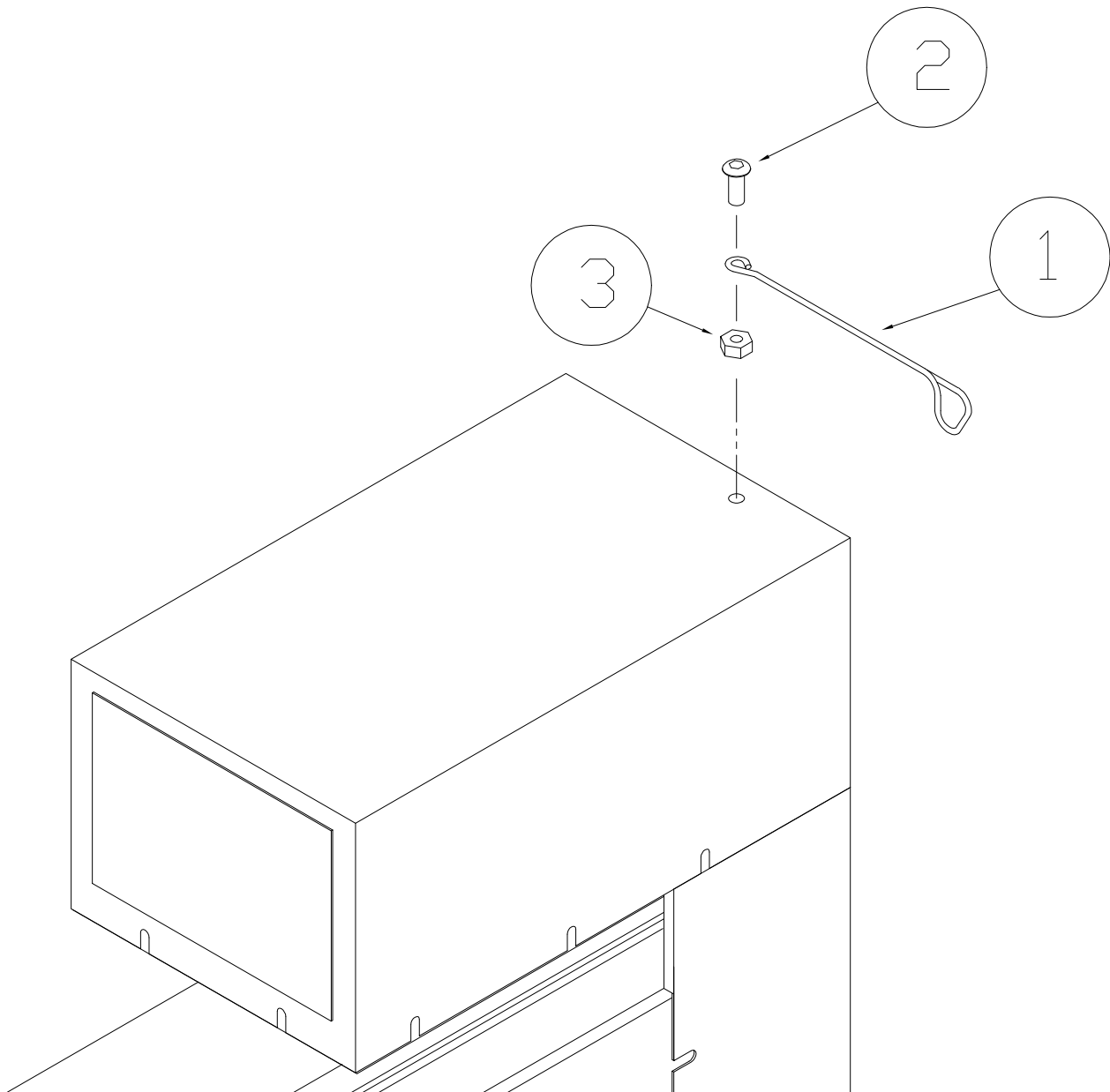

PLATE J2

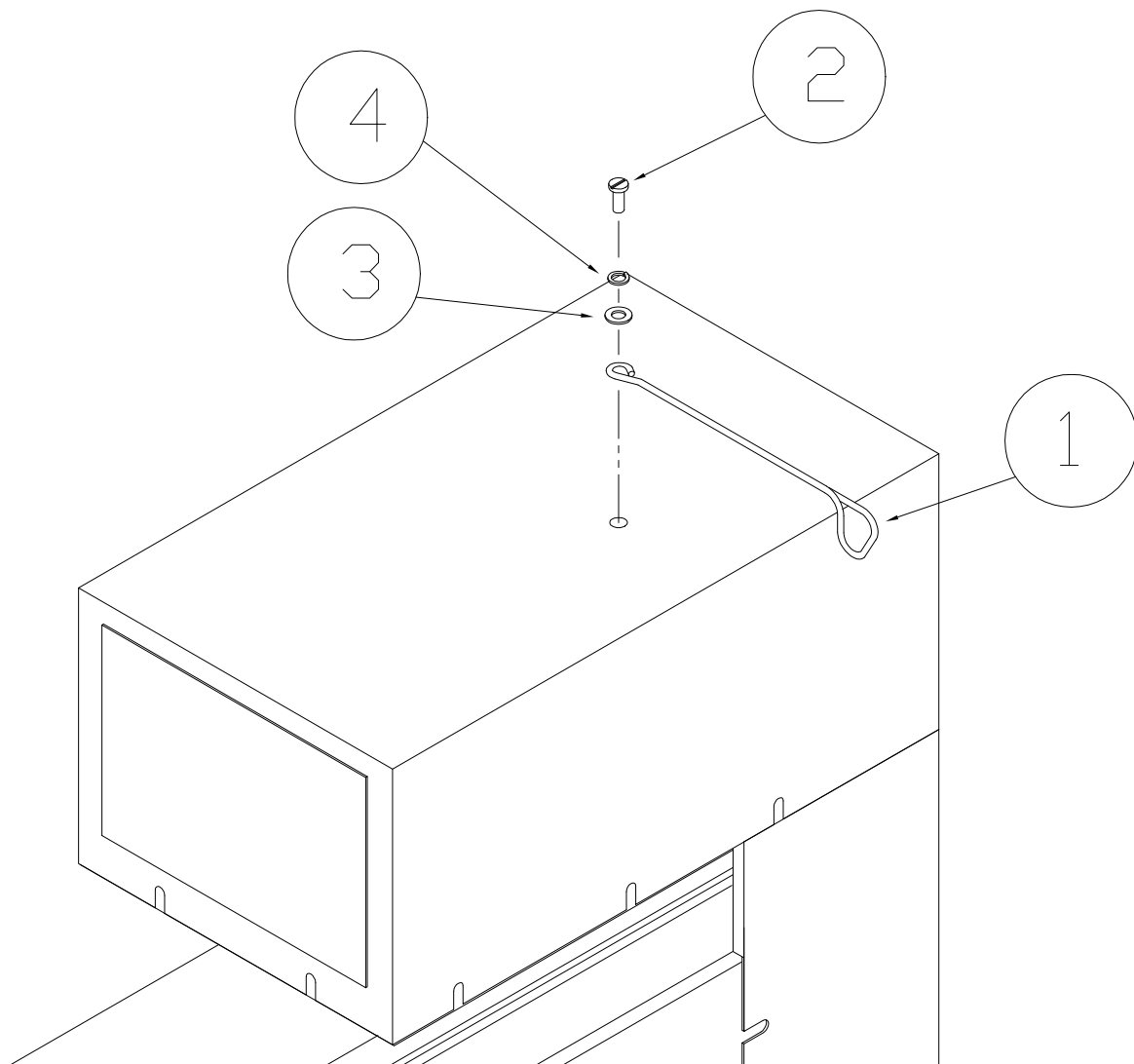
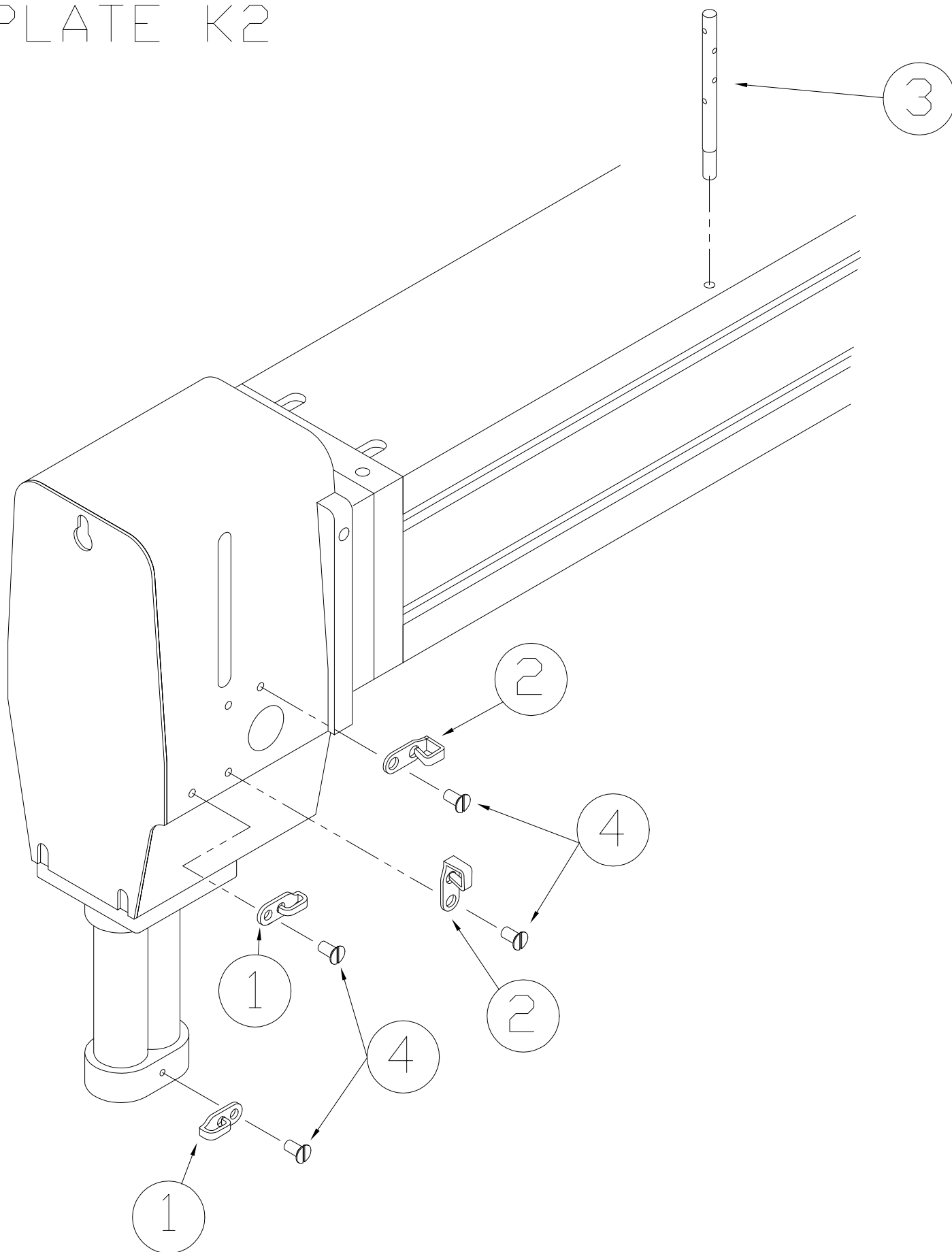

PLATE K2



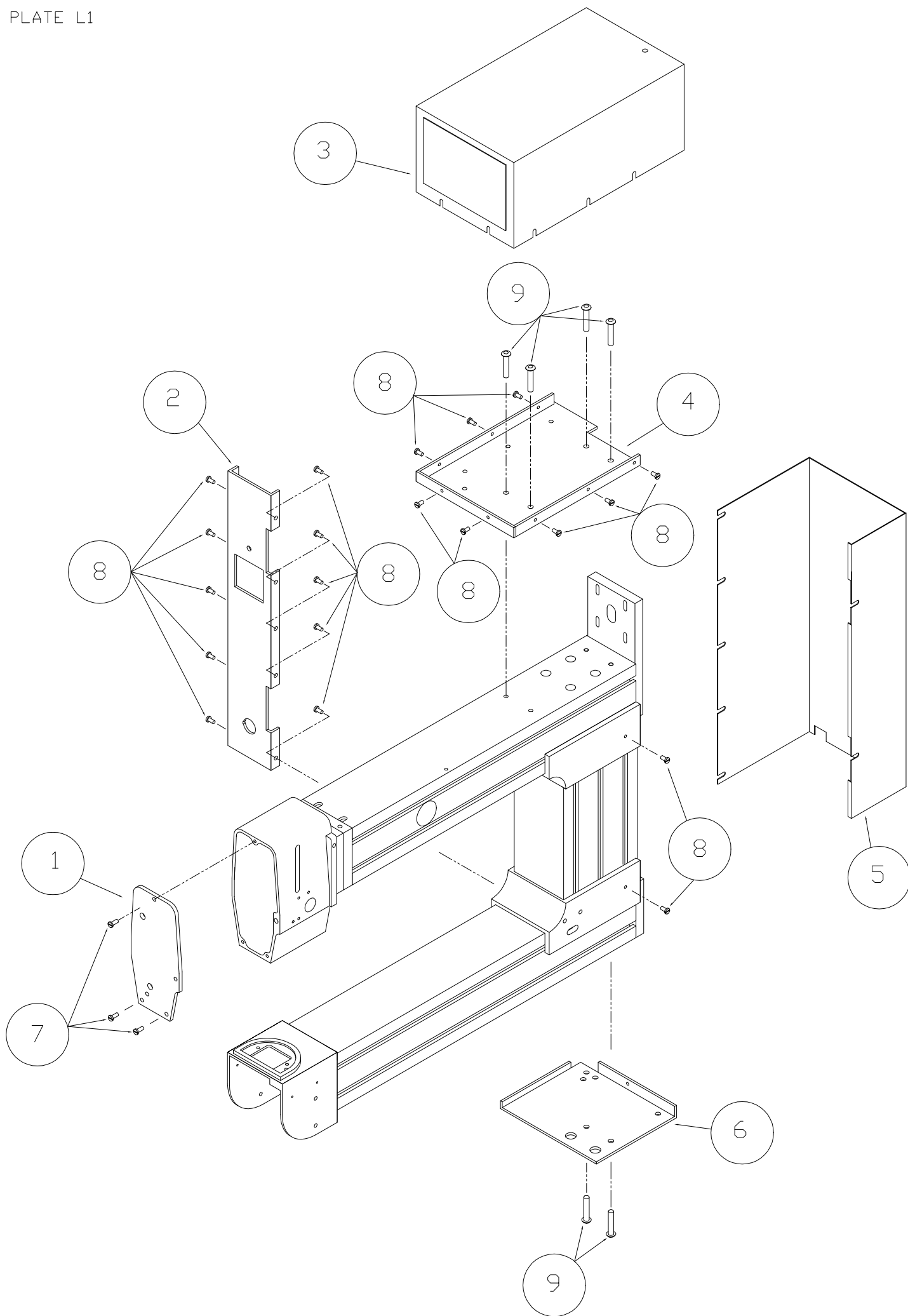
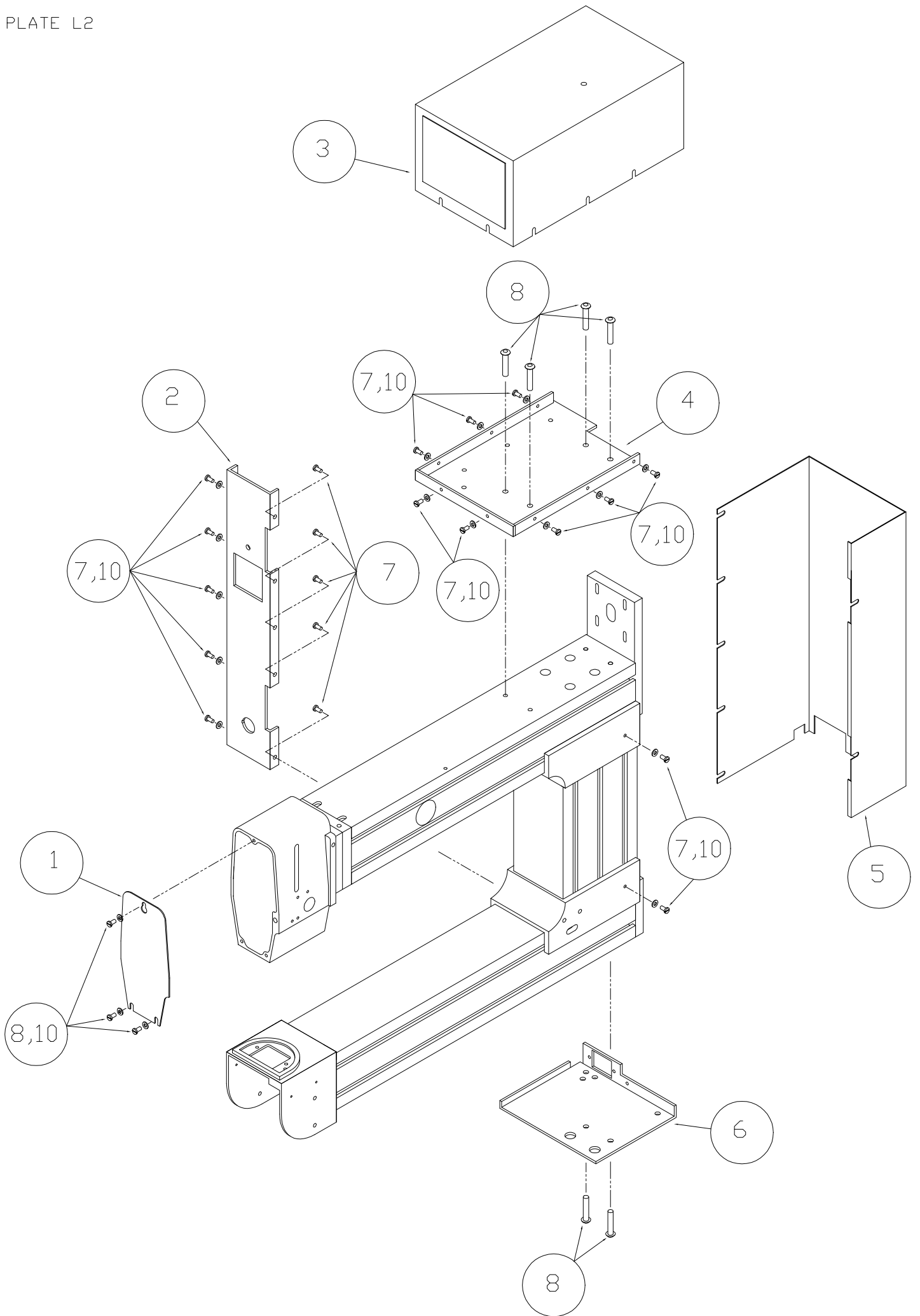

PLATE L2



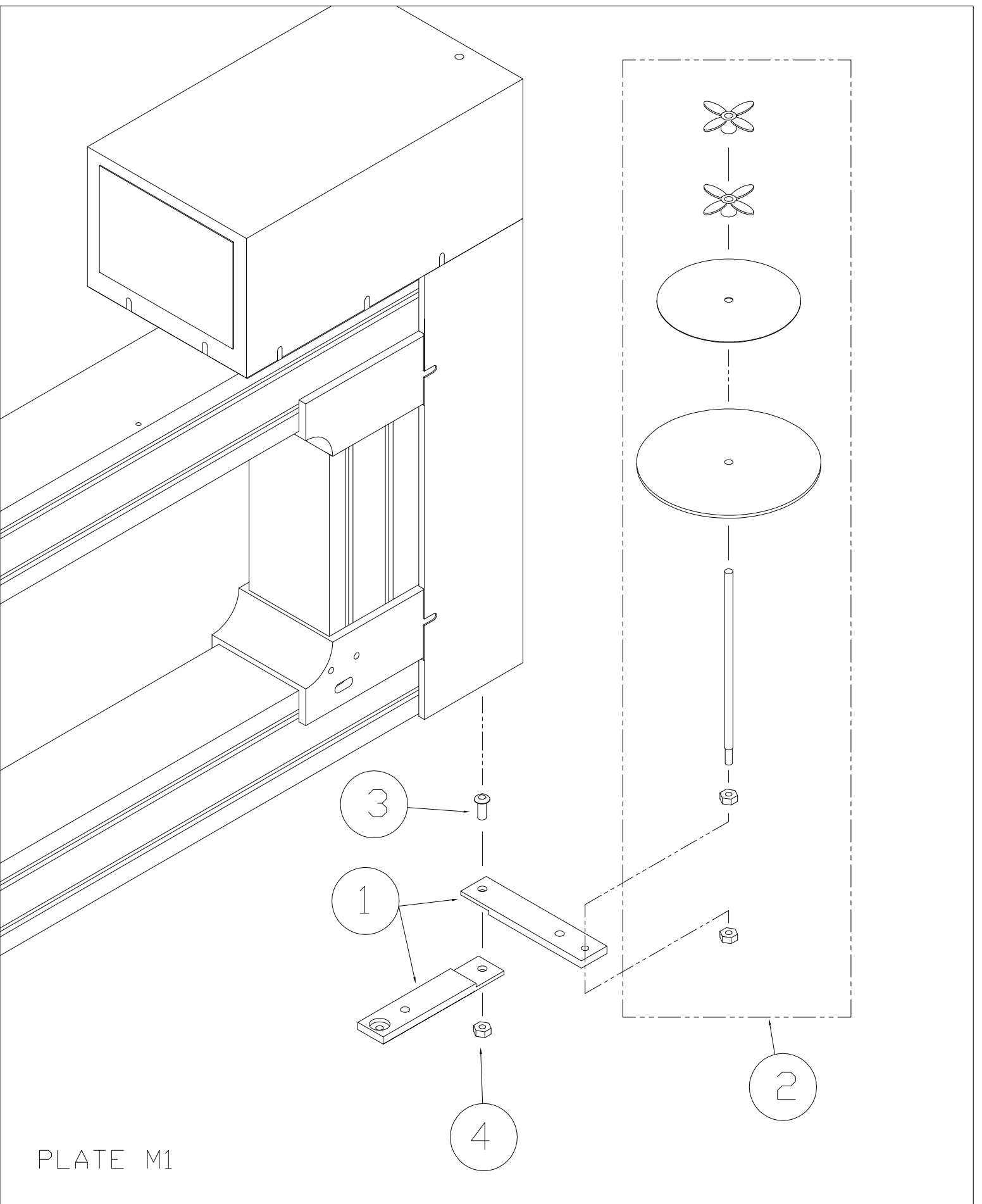
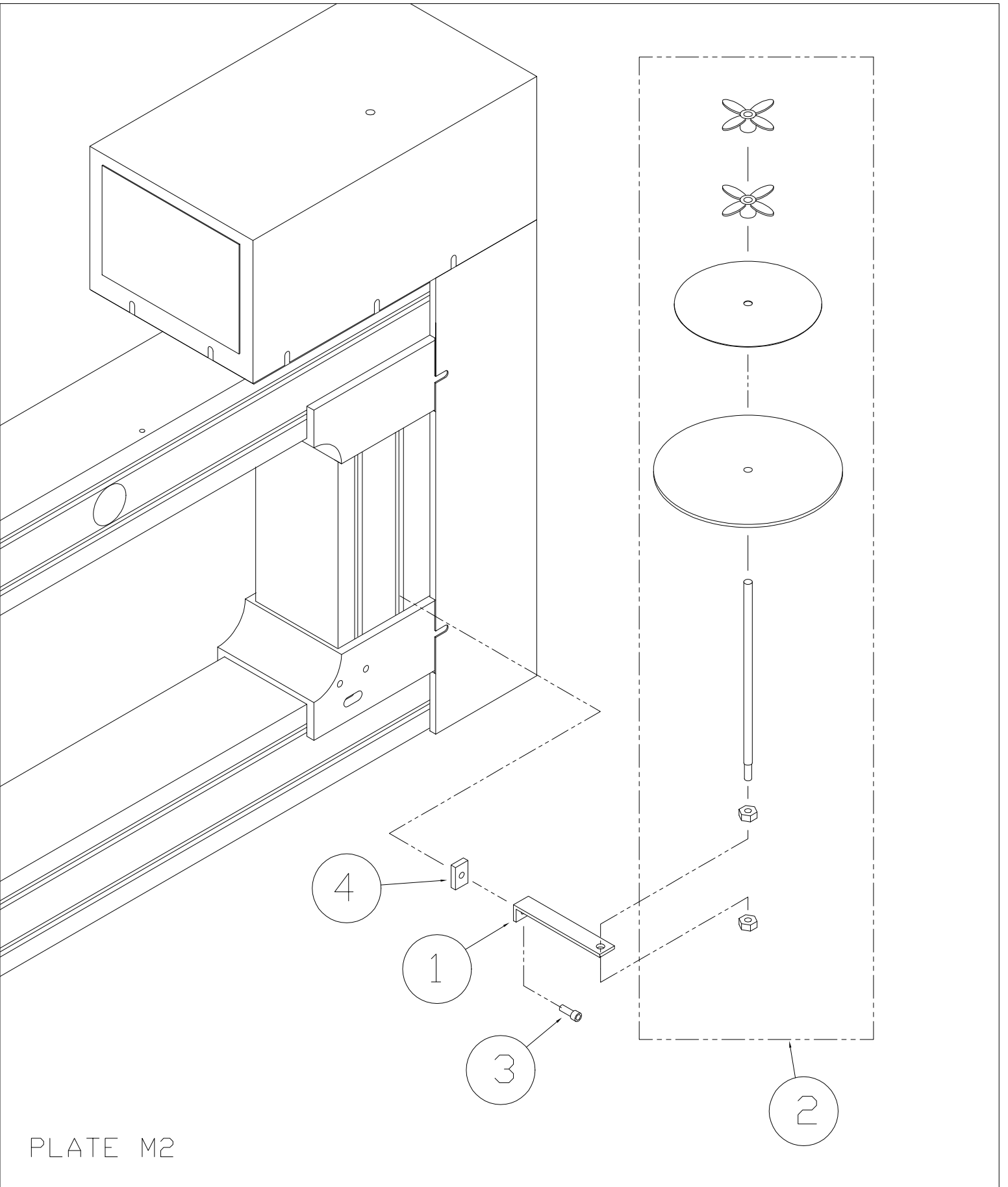
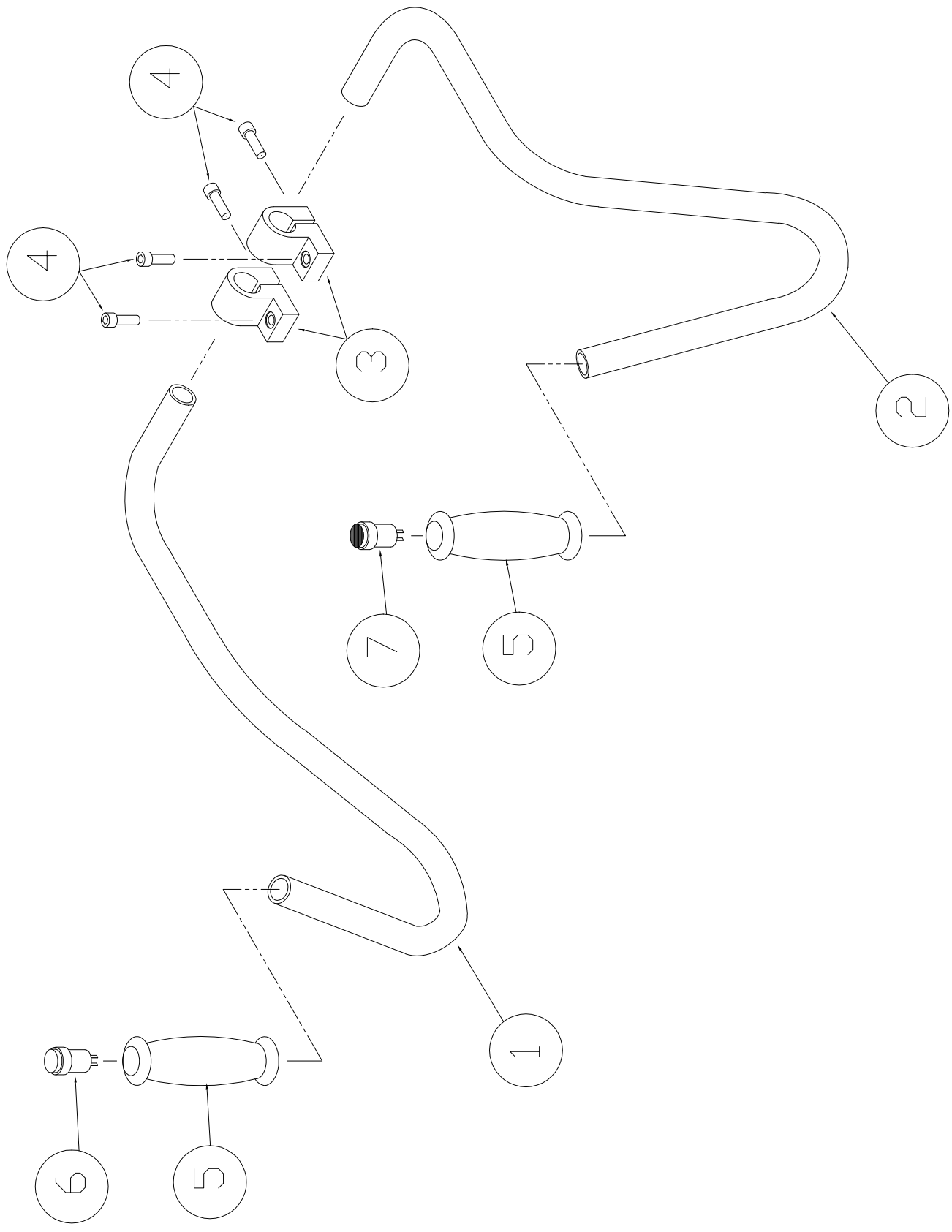
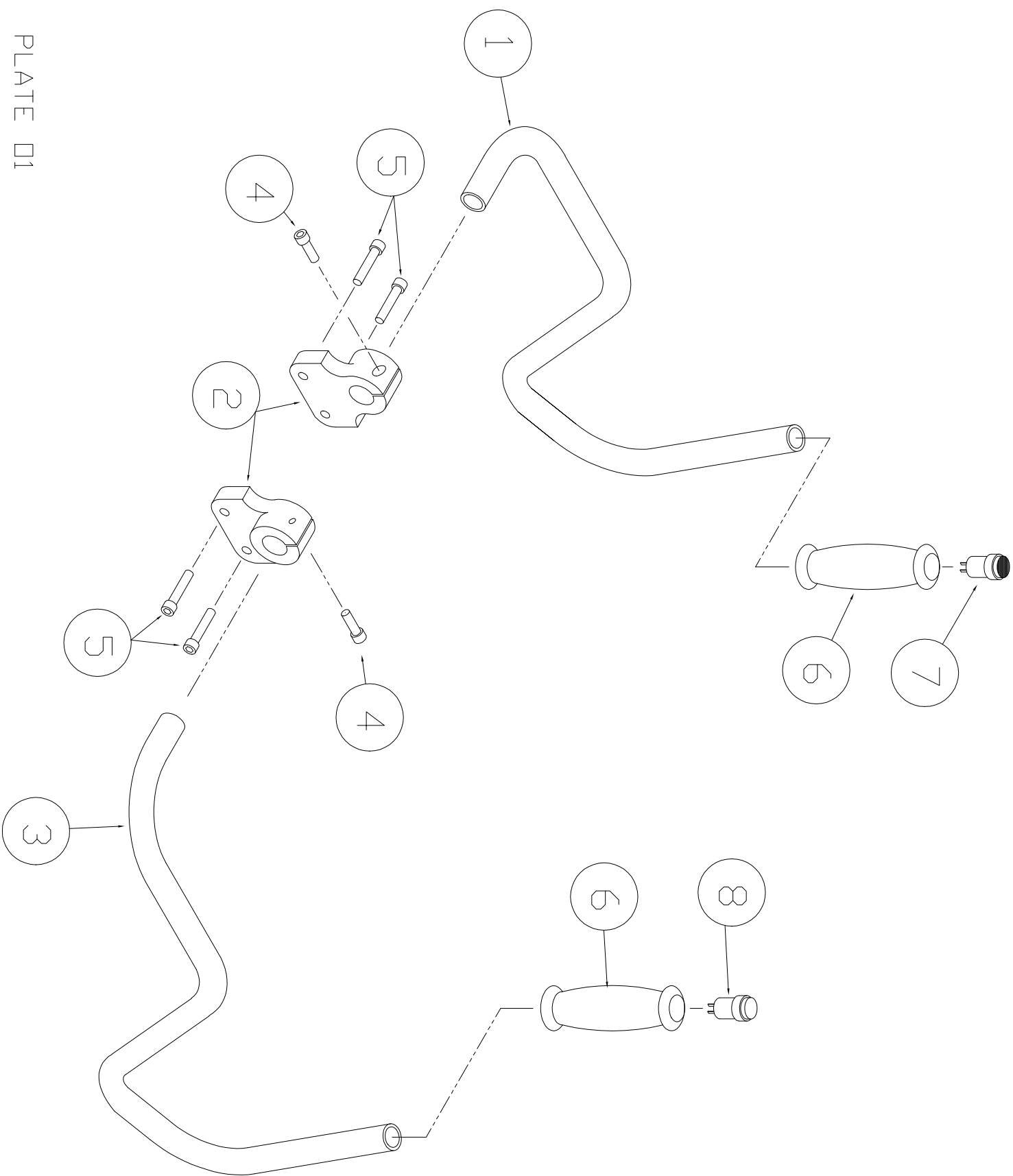
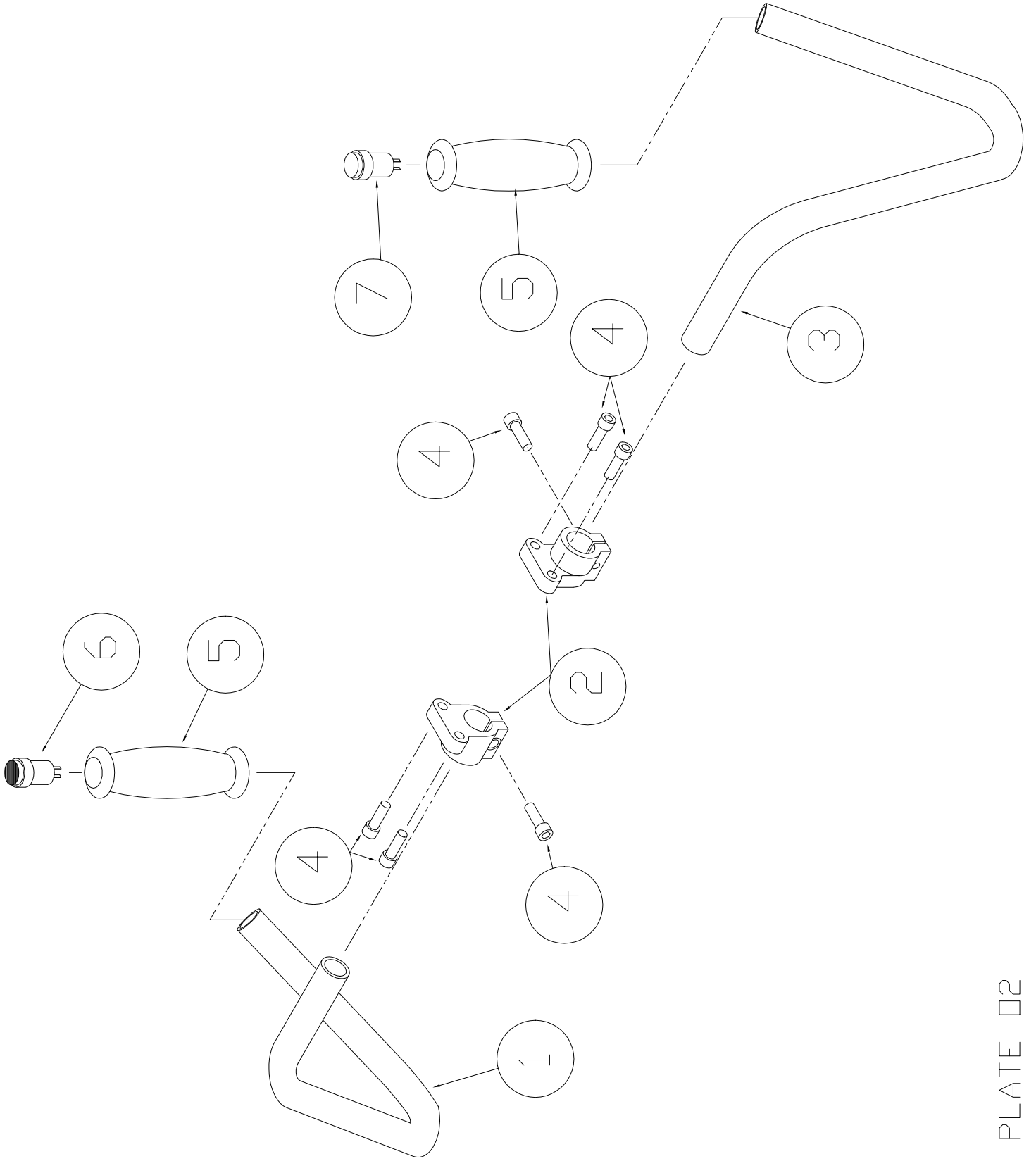

PLATE M1









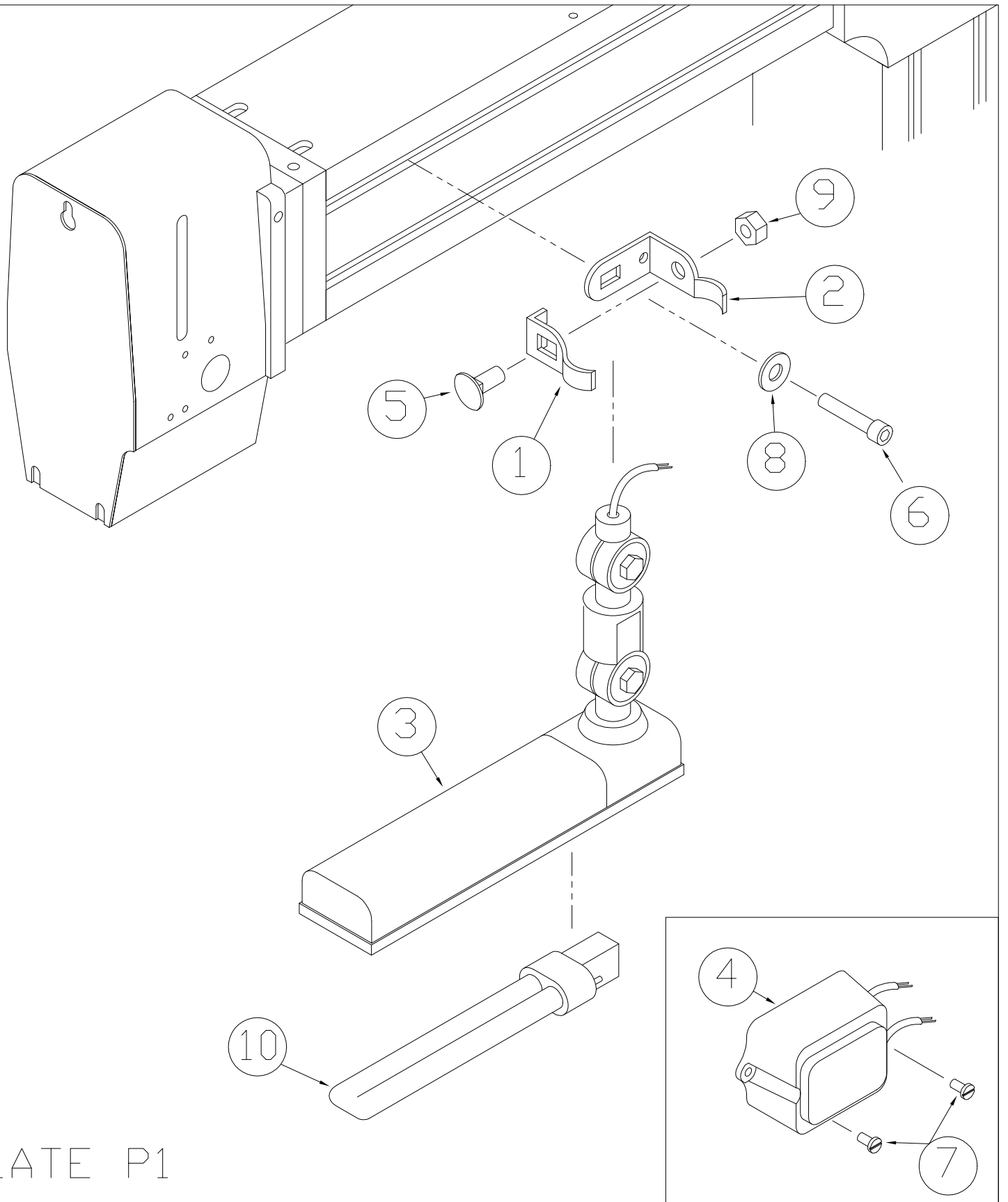

PLATE P1

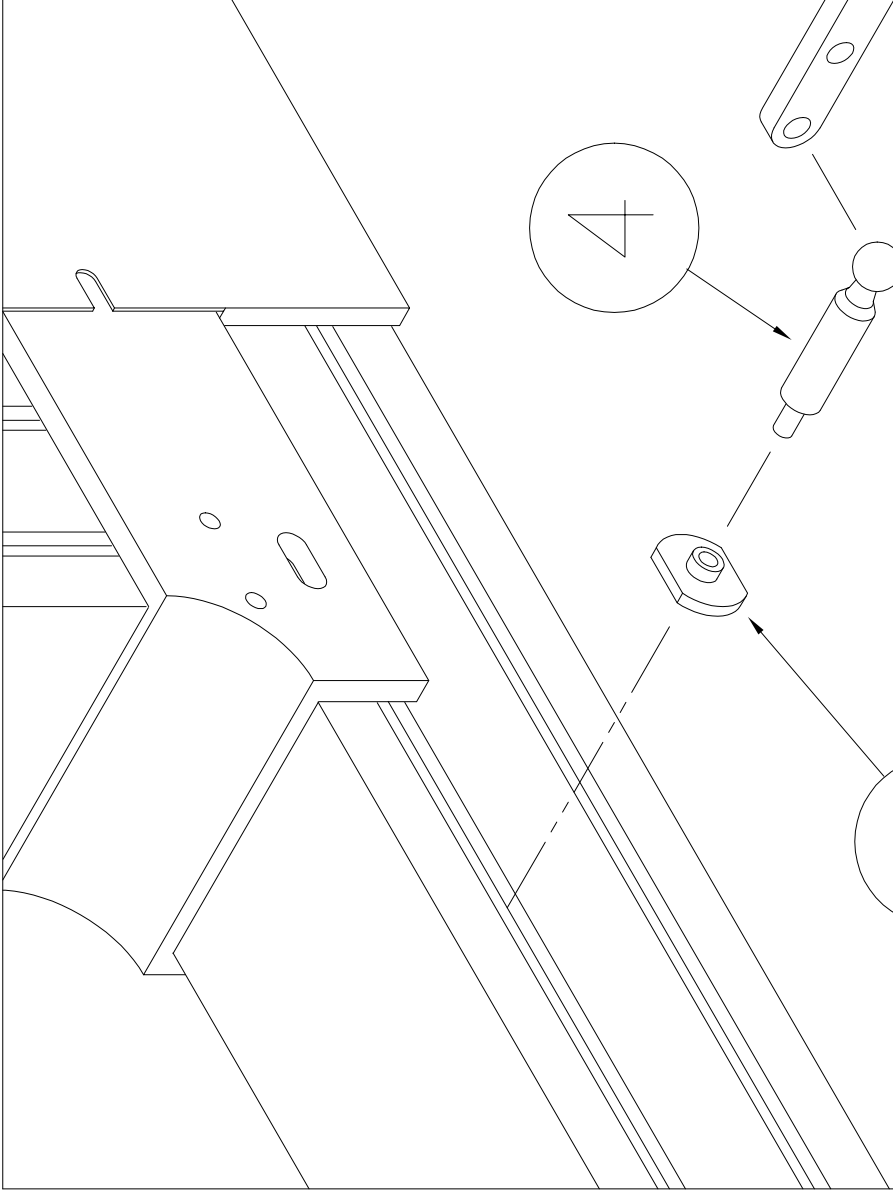
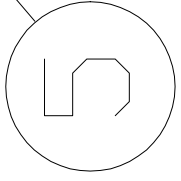
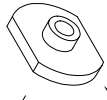
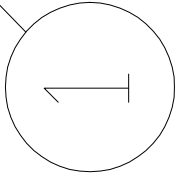
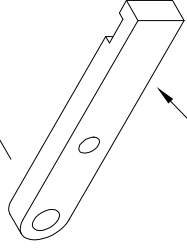
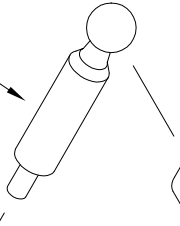
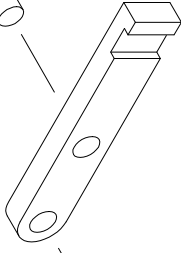
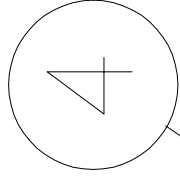
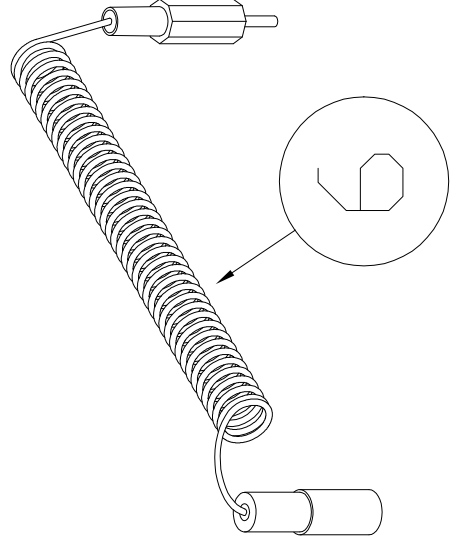
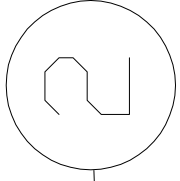
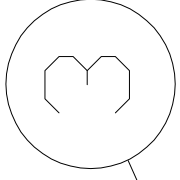
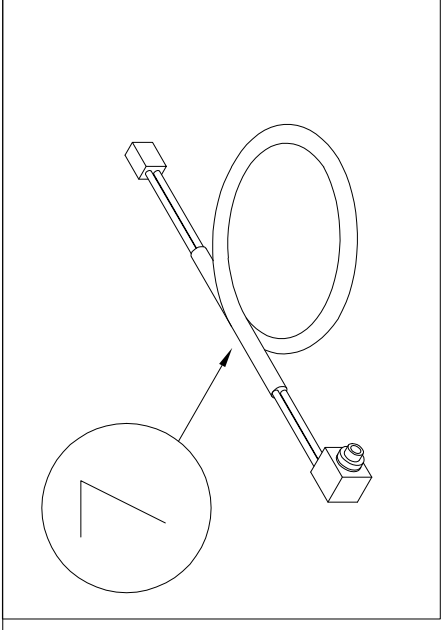
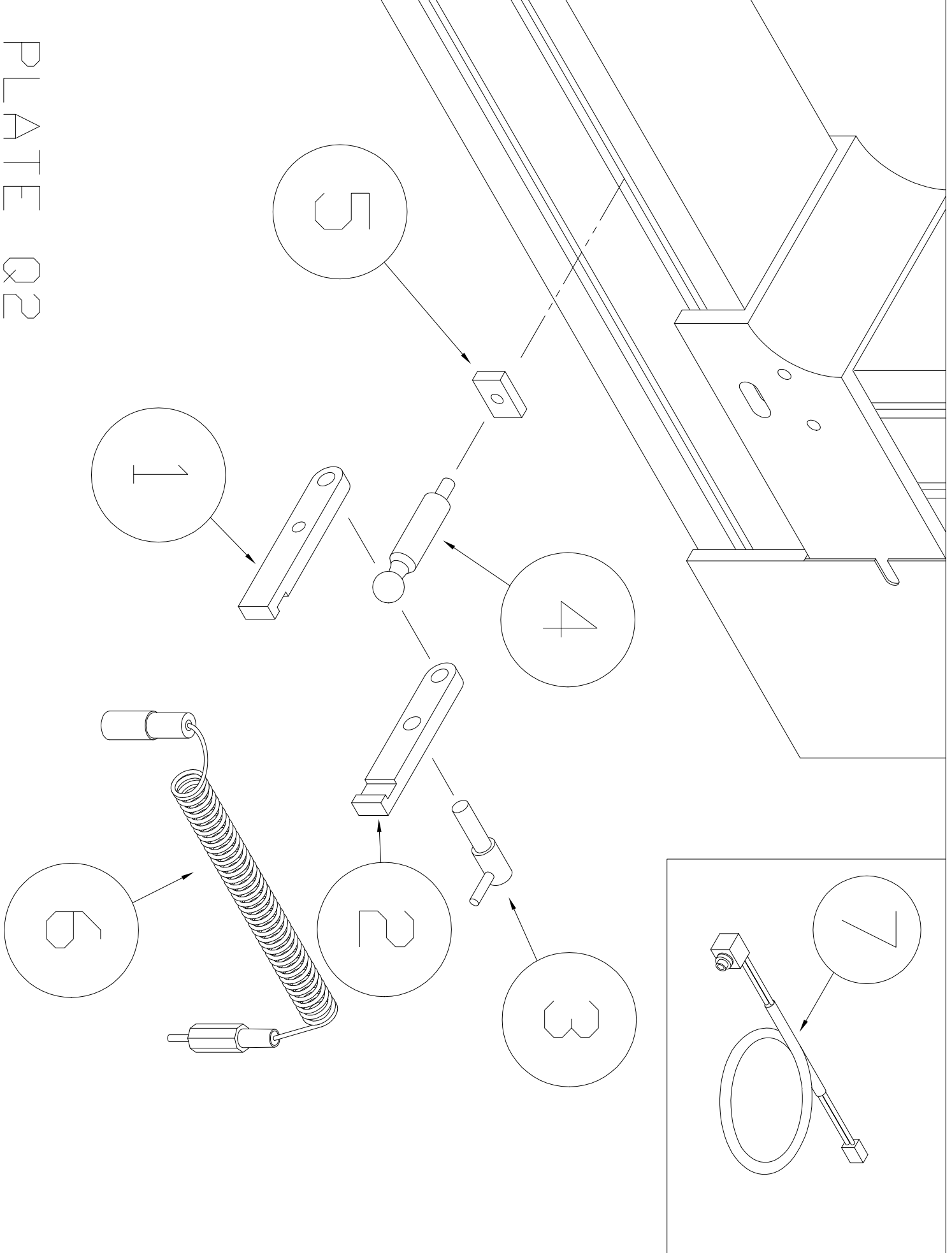

PLATE Q1

PLATE Q2



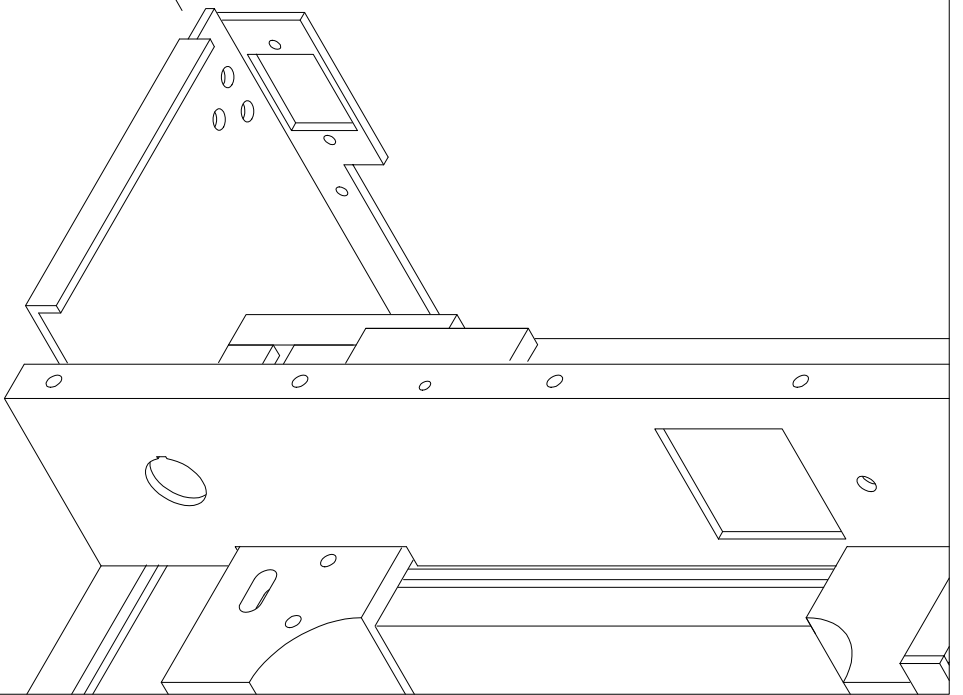
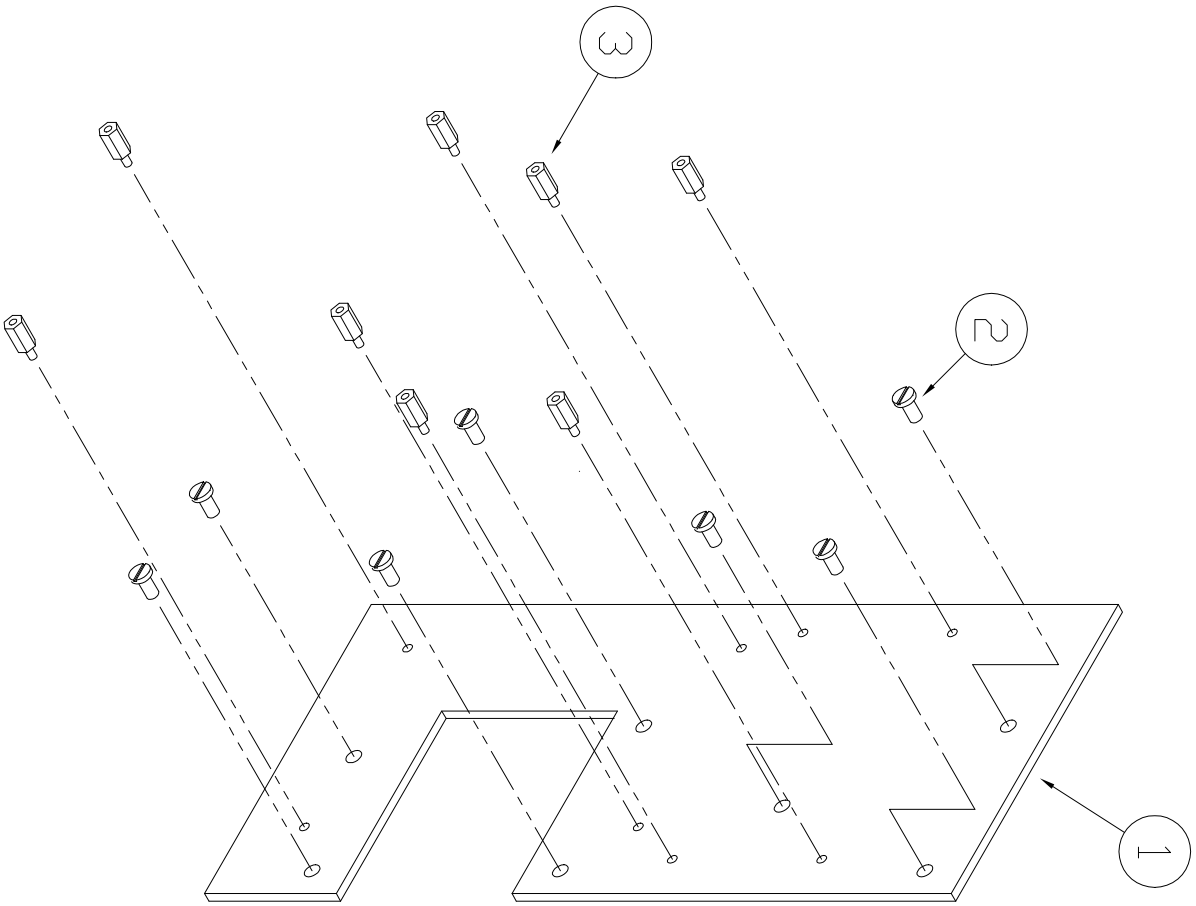

PLATE R1

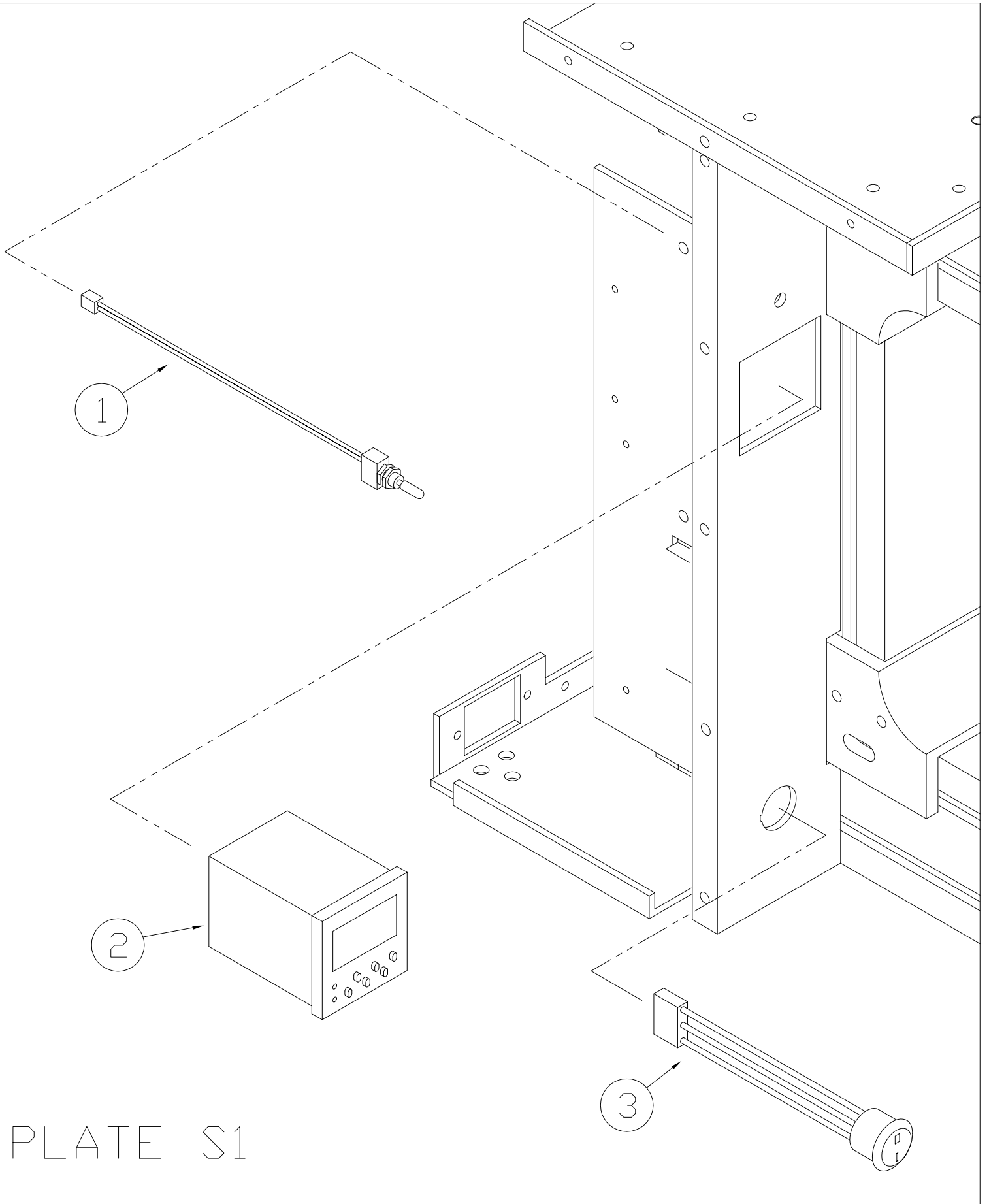

PLATE S1

PLATE T1

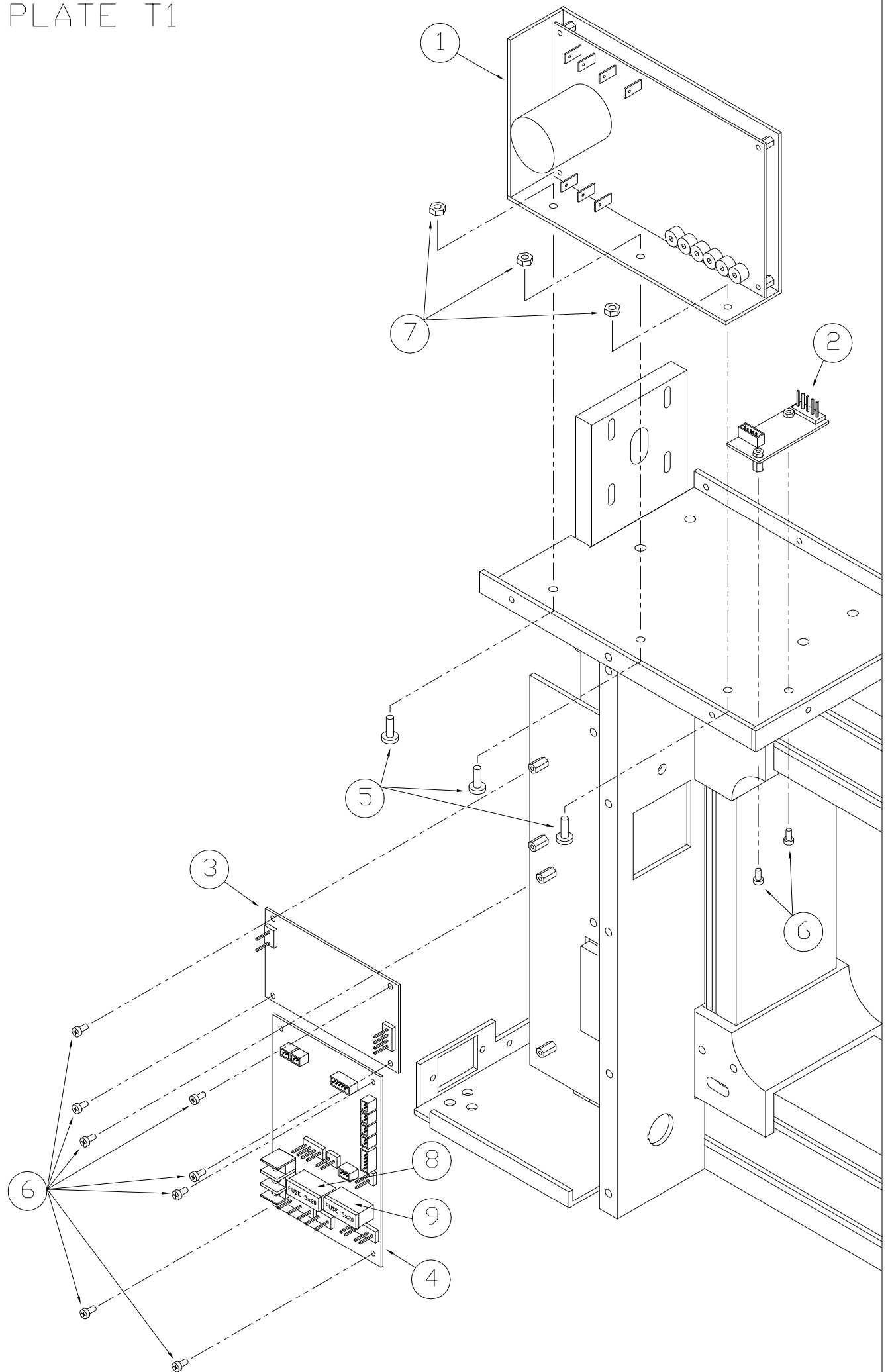
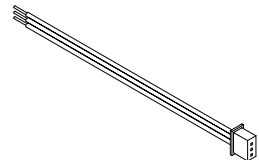
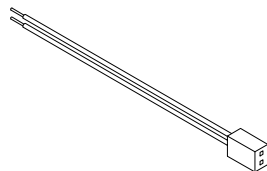
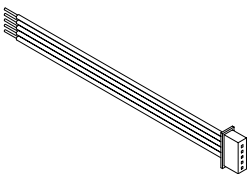
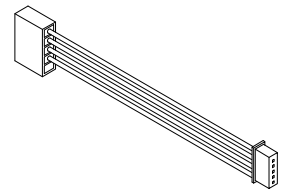
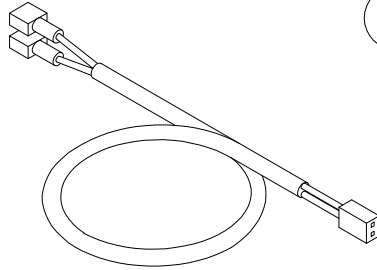
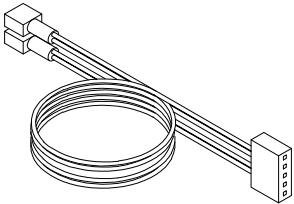
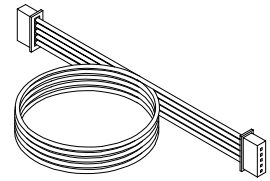
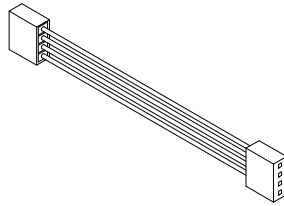
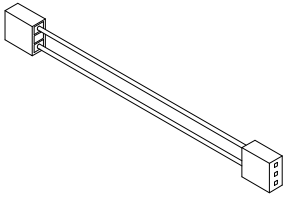
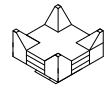
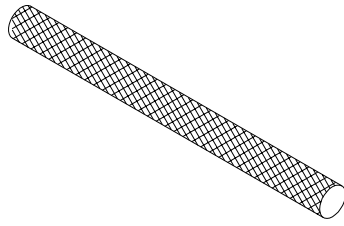
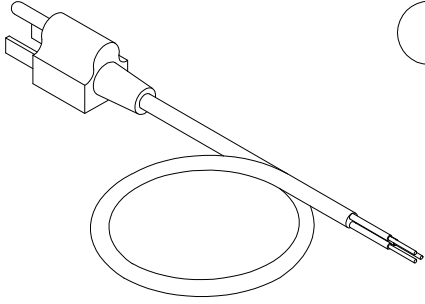

PLATE T2



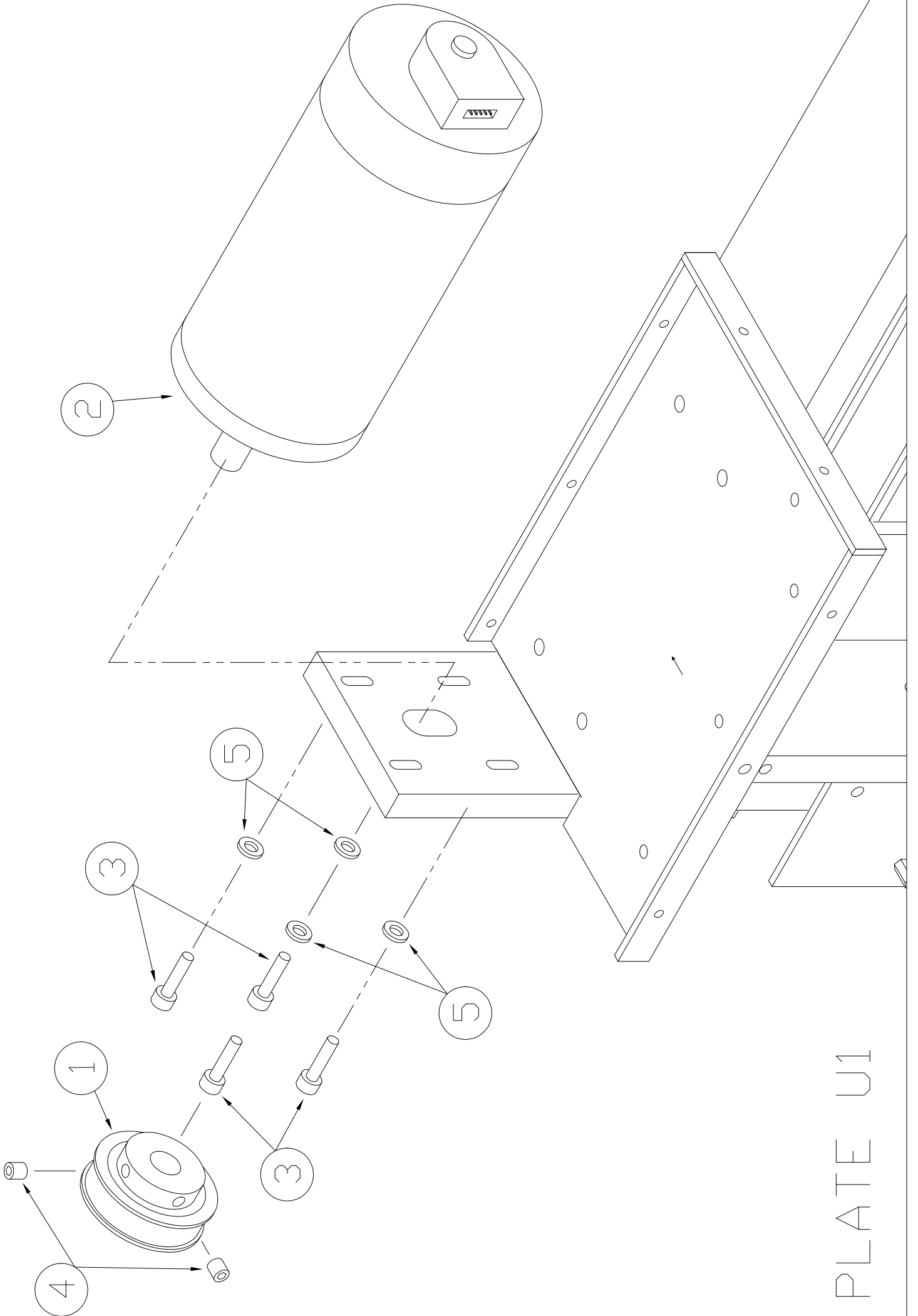

PLATE U1

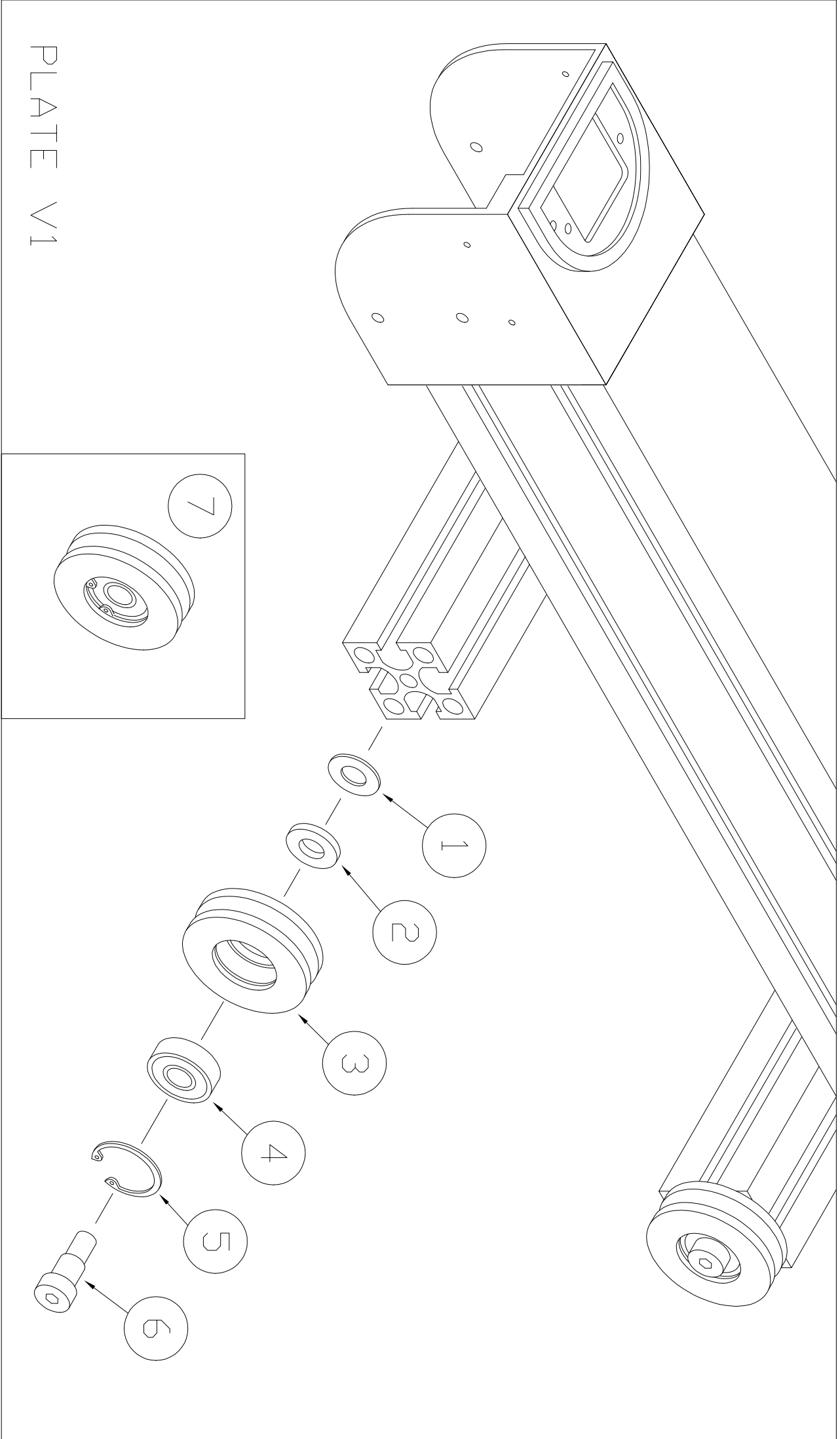
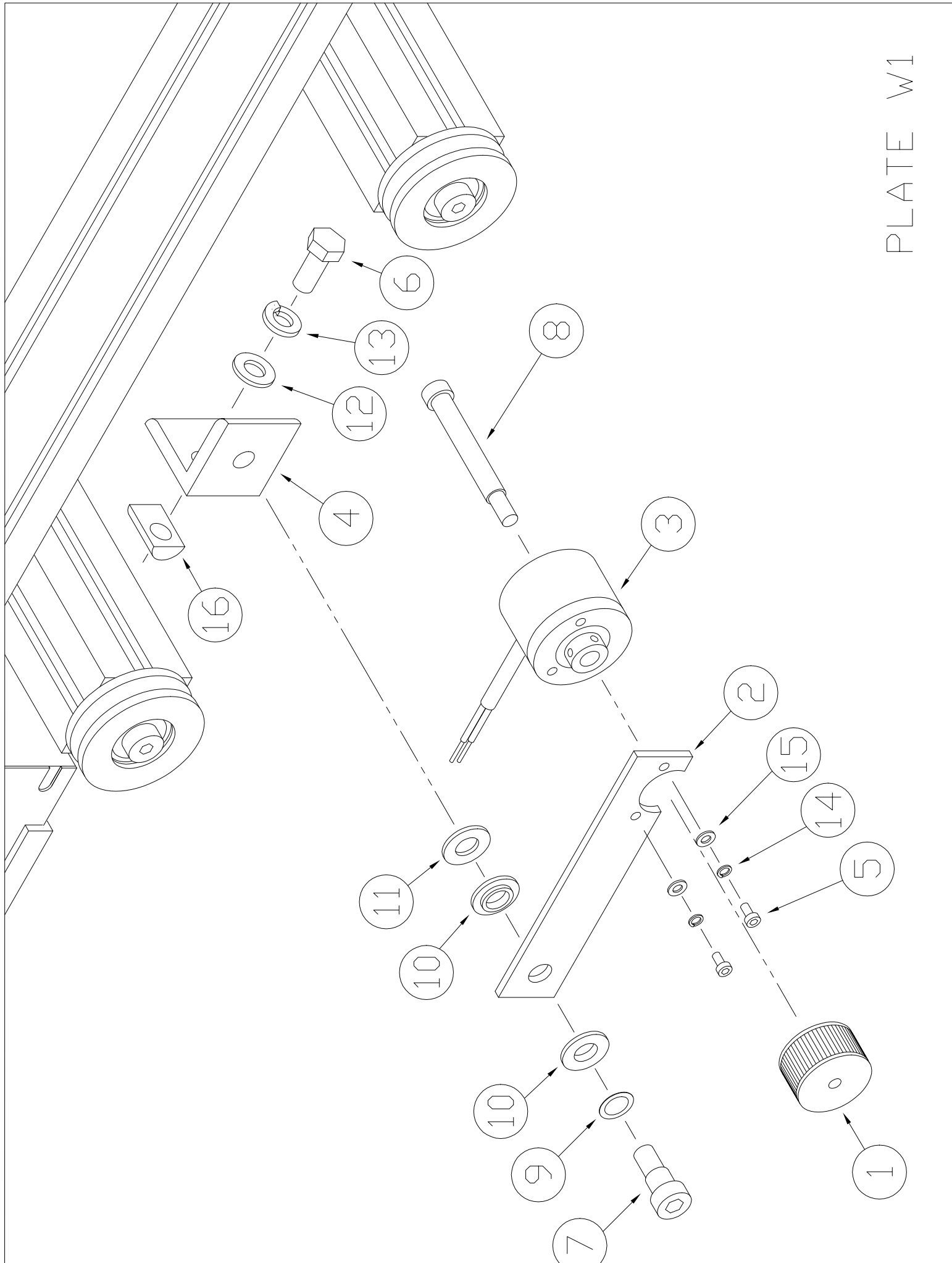

PLATE V1



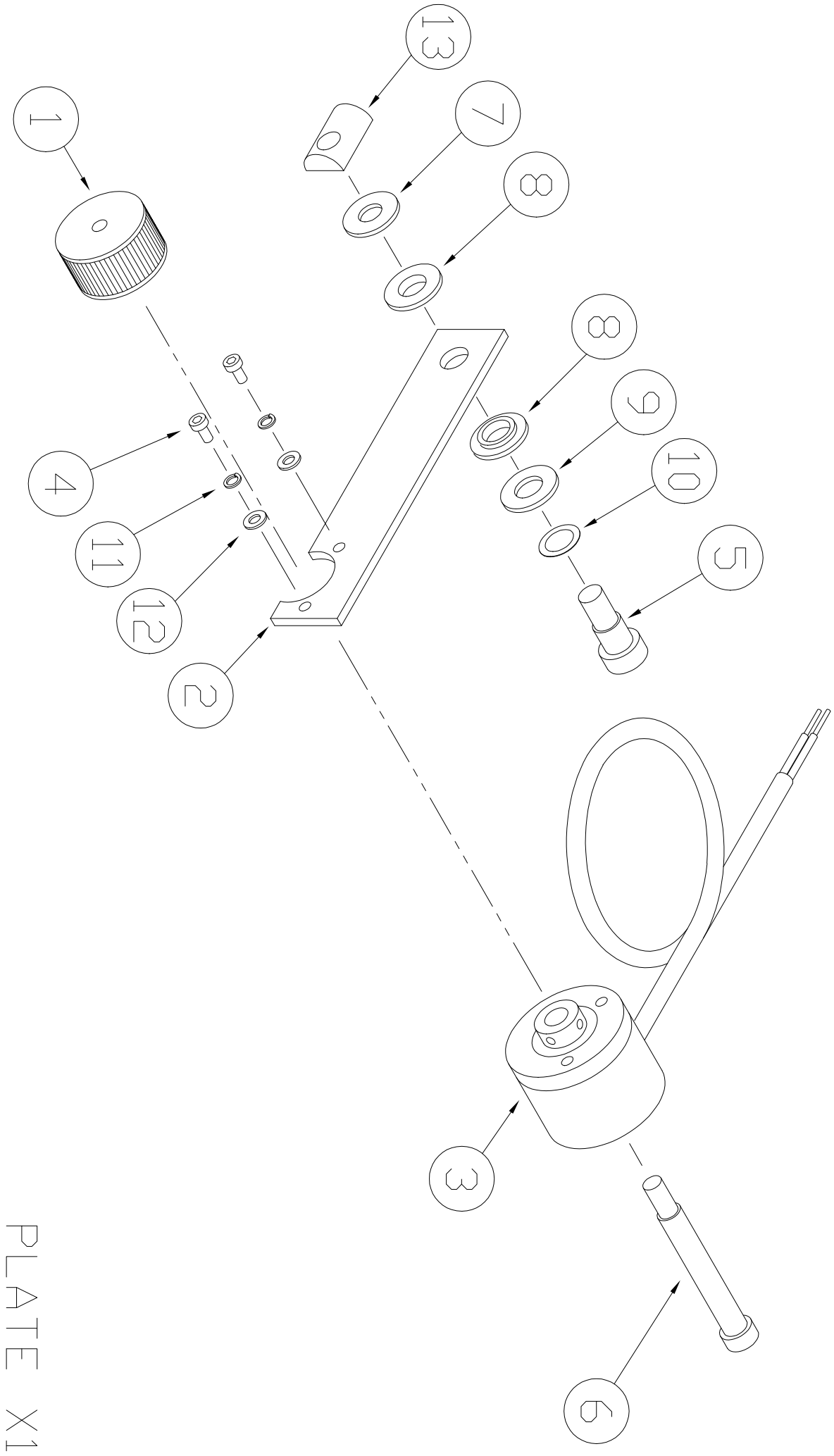

PLATE X1

PLATE Y1

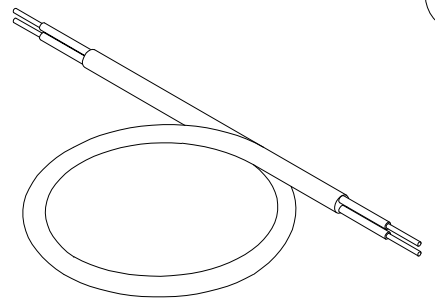
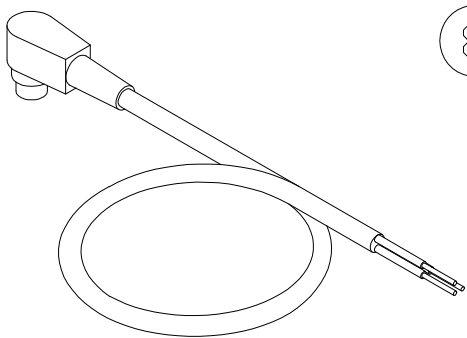
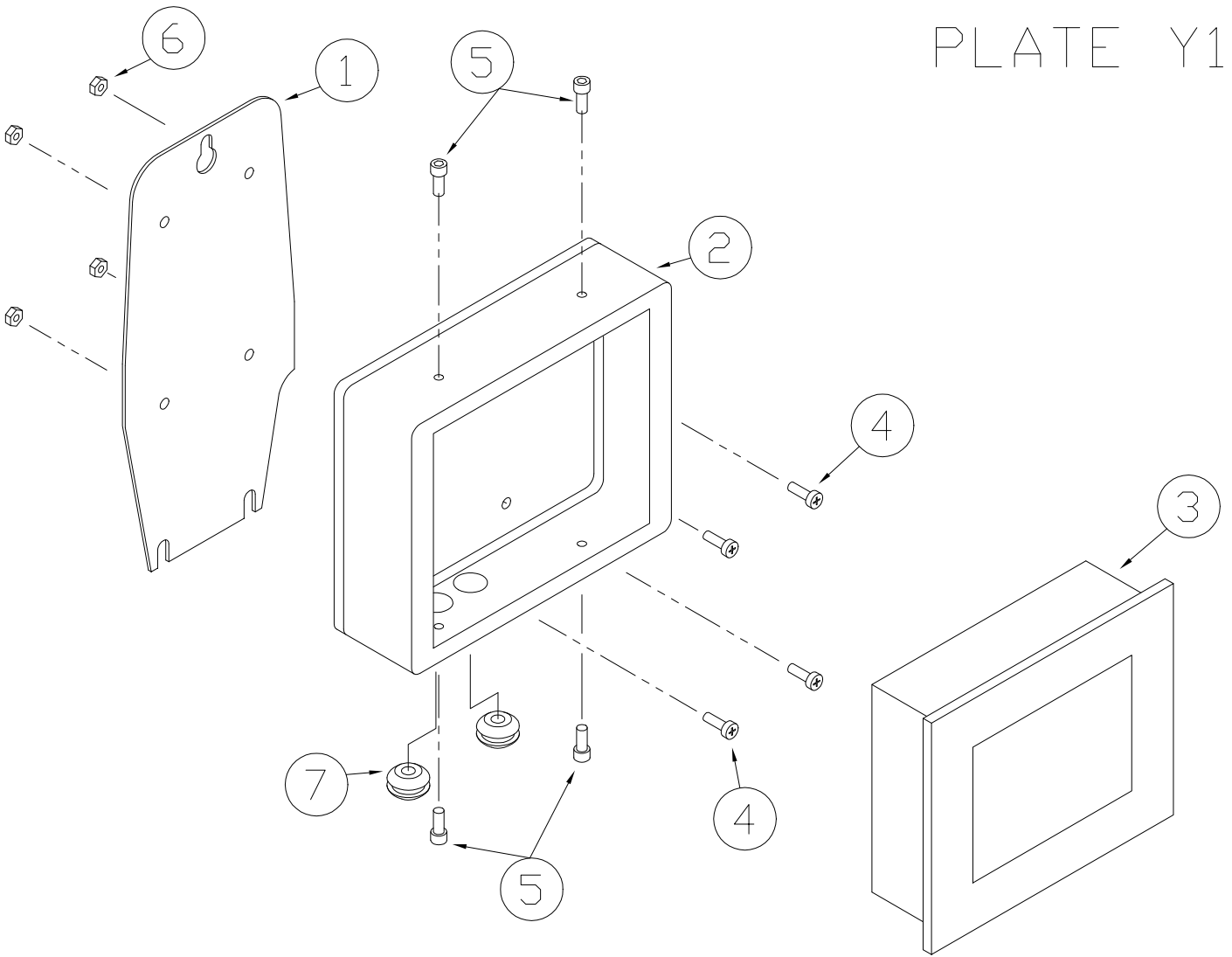

PLATE Y2

