

Spectre LED Light Installation

1.0: Parts List

LED light assembly (Qty. 1)

Allen key (Qty. 1)

Power cord (Qty. 1)

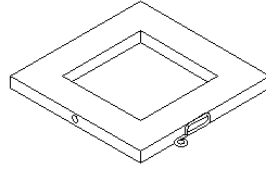

2.0: Installation

Step 1: Make sure the needle is in the UP position.

Step 2: Loosen the head pivot screw located directly behind the top sewhead casting.

Step 3: Press the release lever on the left side of the Innova upper beam and rotate the Innova head clockwise until the needle is pointing directly to the left.

Step 4: Install the LED light assembly onto the needle bar bushing assembly by tightening the (2) set screws in the LED light assembly against the square base of the needle bar bushing assembly. **MAKE SURE THE THREAD GUIDE ON THE LED IS ON THE SAME SIDE AS THE TENSION ASSEMBLY OF THE INNOVA. SEE ILLUSTRATION BELOW.**

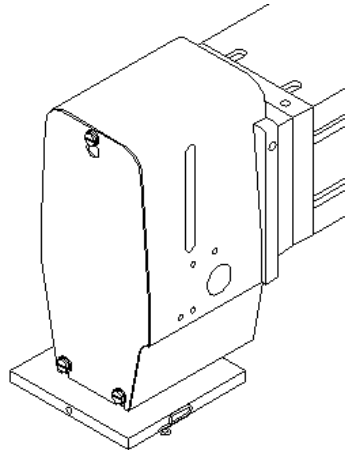

Step 5: Press the release lever and rotate the Innova head back to the normal position.

Step 6: While holding the needle in the center of the hole of the needle plate, tighten the head pivot screw.

Step 7: Connect the power cord to the LED light and to the Laser power outlet on the right side of the Innova.

3.0: Operation

The LED light is equipped with white and black light LEDs. The toggle switch mounted directly on the LED assembly is a three position switch that selects the desired light output. To operate the LED light use the following steps.

Step 1: Turn ON the Innova

Step 2: Turn the laser light toggle switch, located on the Innova, to ON.

Step 3: Turn the toggle switch, located on the LED light assembly to the desired output; White, OFF (center position) or Black light.