

ABM International, Inc.

Lightning Stitch Checklist

9/13/2013

- 1) Piggy backed board assembly (1)

Piggy back board assembly tested?	Yes	No
24v	passed	
XB	passed	
XA	passed	
YB	passed	
YA	passed	
SAFE	passed	
S/S	passed	
- 2) Motor & board assembly (1)

Motor and board assembly tested?	Yes	No
----------------------------------	-----	----
- 3) Touch screen computer (1)

Programmed?	Yes	No
-------------	-----	----
- 4) M5 x 20mm SHCS bolts (4)
- 5) #10 SAE flat washer (8)
- 6) #10 lock washer (4)
- 7) 6" Push button extension cable (1)
- 8) 9-pin to phone cord adapter (1)
- 9) Phone cord (1)
- 10) 1ft. Network communication cable (1)
- 11) 9-pin serial communication cable (1)
- 12) 2-conductor touch screen power cable (1)
- 13) Square plug for PLC knockout (1)
- 14) Bag of 4" wire ties
- 15) 3mm x 14mm bolt (4) (for clear plastic face plates)
- 16) Wiring diagram
- 17) Touch screen mounting hole template or drawing

Checked by:

Date:

THIS PAGE IS INTENTIONALLY LEFT BLANK

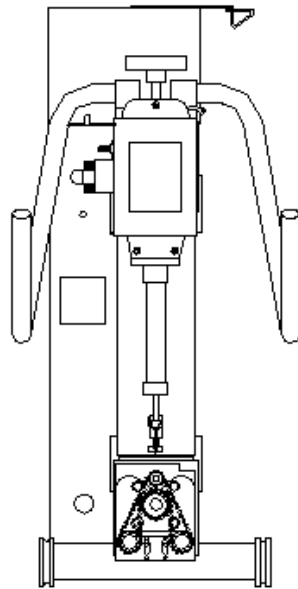

ABM International, Inc.

Lightning Stitch Assembly

1.0: Parts List

Lightning stitch motor and drive assembly (Qty. 1)

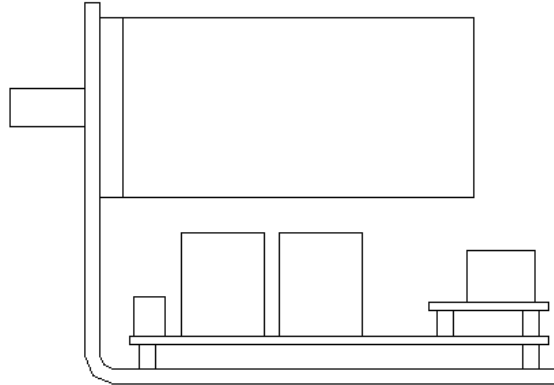

Lightning stitch piggy backed controller board assembly (Qty. 1)

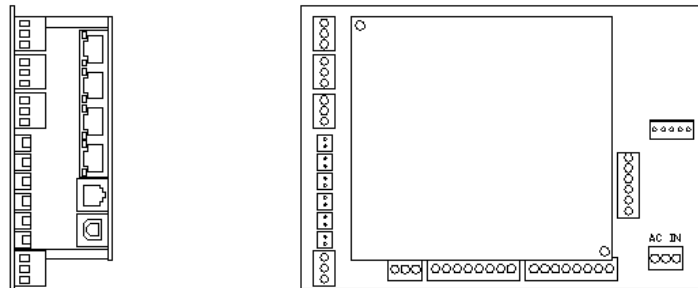

Touchscreen (Qty. 1)

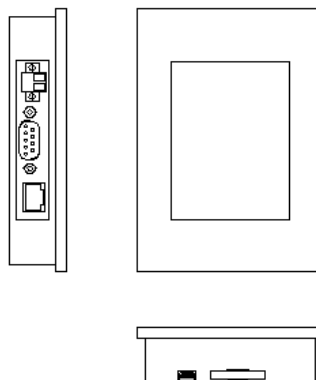

9-pin Serial cable (Qty. 1)

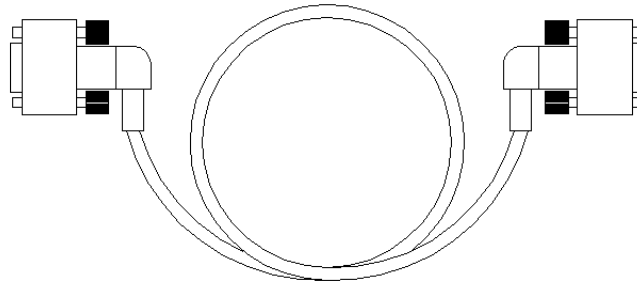

9-pin Adapter and phone cord (Qty. 1)

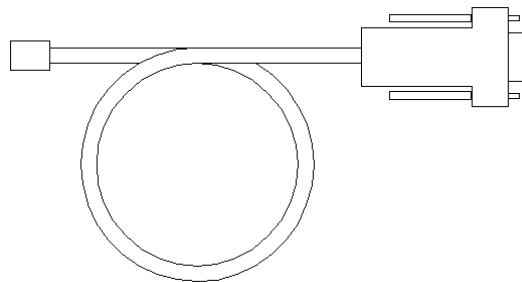

Communication cable (Qty. 1)

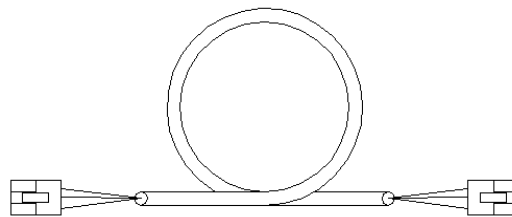

Touchscreen power cable (Qty. 1)

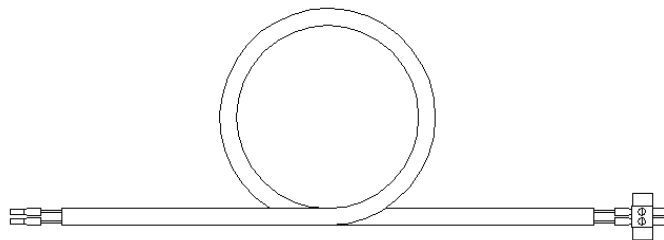

6" Pushbutton extension cable (Qty.1)



Square hole plug (Qty. 1)

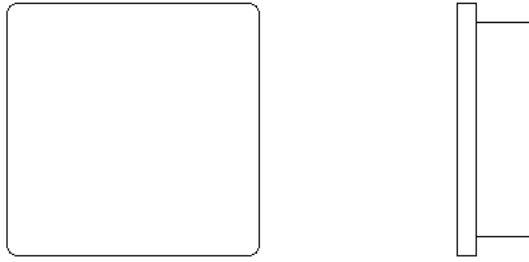

Bag of nylon ties (Qty. 1)

Bolt Kit:

Socket head cap screw:

(Qty. 4) M5 x 20mm



Flat washer:

(Qty. 8) #10



Lock washer:

(Qty. 4) #10



2.0 Lightning Stitch Assembly

Installing a Lightning Stitch assembly onto an existing machine requires the removal of the original electronics from the machine.

NOTE: MAKE SURE THE MACHINE IS UNPLUGGED FROM THE OUTLET BEFORE ATTEMPTING TO SERVICE THE INNOVA. FAILURE TO DO SO CAN RESULT IN SERIOUS INJURY OR DEATH.

- 1) Unplug the machine from all power sources. Loosen, but do not remove the cover screws and remove the top motor cover and the rear electronics cover from the machine.

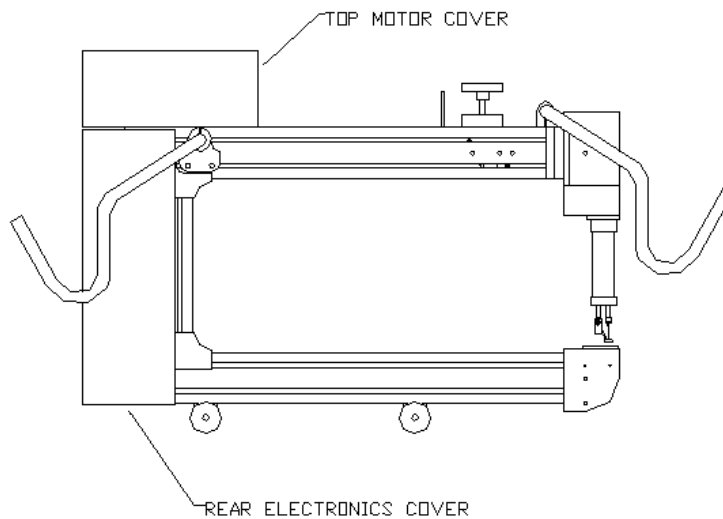

- 2) Remove the motor controller, PLC, power supply and the main control board from the rear of the Innova. Save the screws and hardware. Take special care to note the (4) screws that held the lower yellow main control board to the machine – you will need to re-use these in a later step. Also, keep the encoder cables, power cord and fluorescent light ballast and cabling attached to the machine.

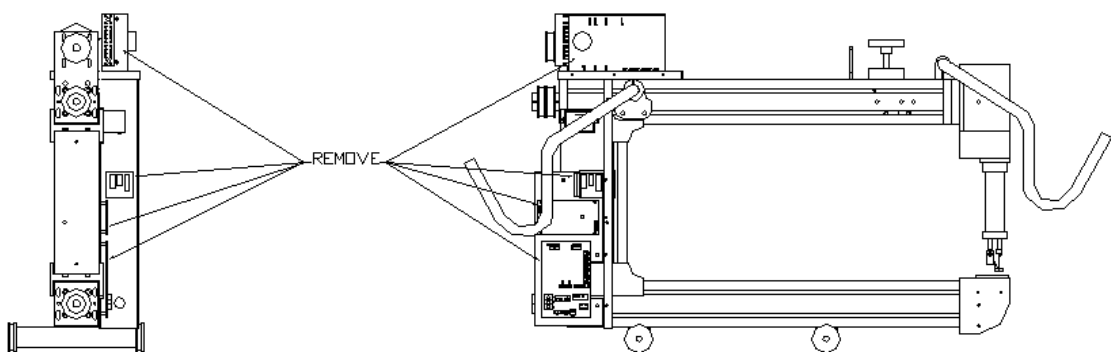

- 3) Remove the top (4) standoffs and remove the small circuit board and standoffs from the top of the machine

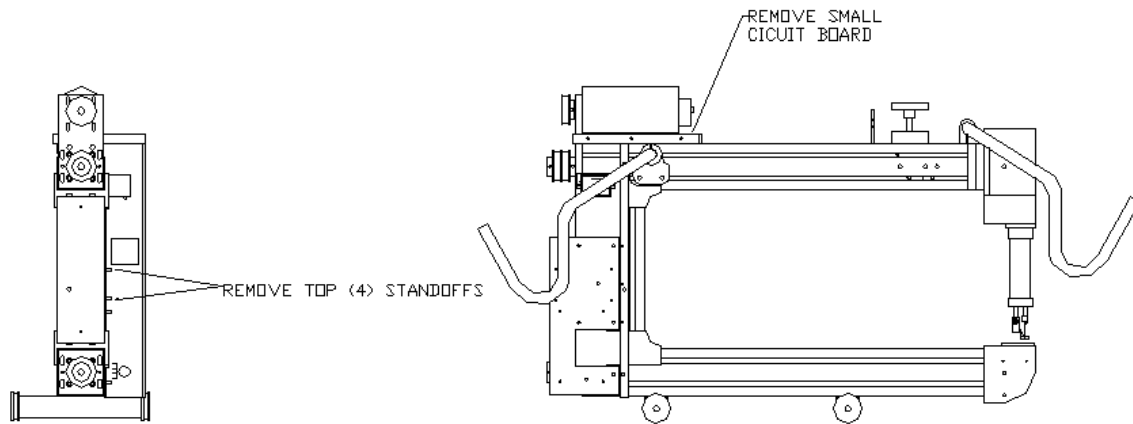

- 4) Remove the pulley from the motor shaft and remove the motor from the machine.

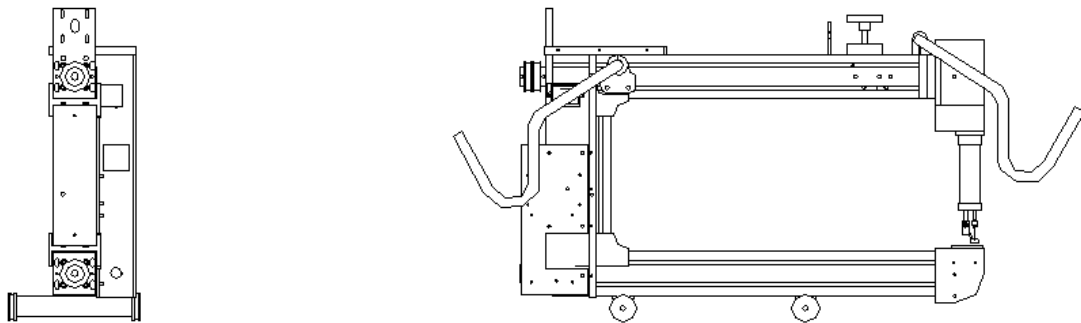

- 5) Remove the front face plate from the machine and drill the (4) mounting holes for the touchscreen using the supplied template and a 5/32 diameter drill bit. **WARNING: MAKE SURE TO CHECK THE TEMPLATE IS PRINTED TO THE CORRECT SCALE BY MEASURING THE 3 INCH LONG SCALE ON THE TEMPLATE PAGE. IF THE SCALE DOES NOT MEASURE 3 INCHES EXACTLY DO NOT USE THE TEMPLATE – CALL ABM.** Mount the touchscreen to the front face plate using the supplied 3mm screws. Install the touchscreen so that the connectors and plugs on the side of the screen face to the left.

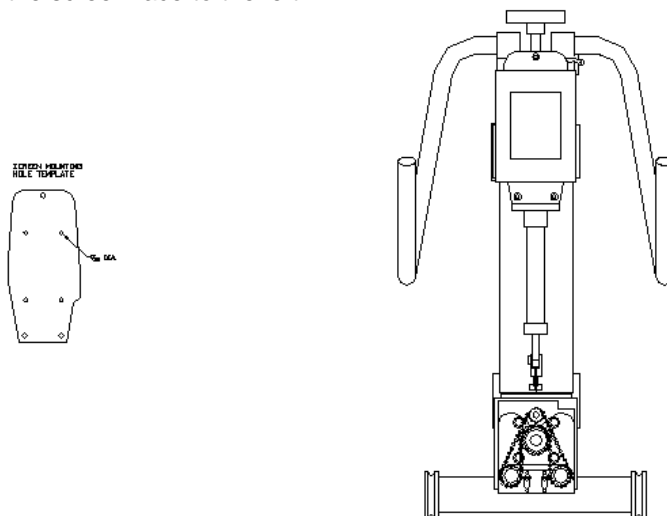

- 6) Remove the side face plate screws and remove the side face plate from the machine.

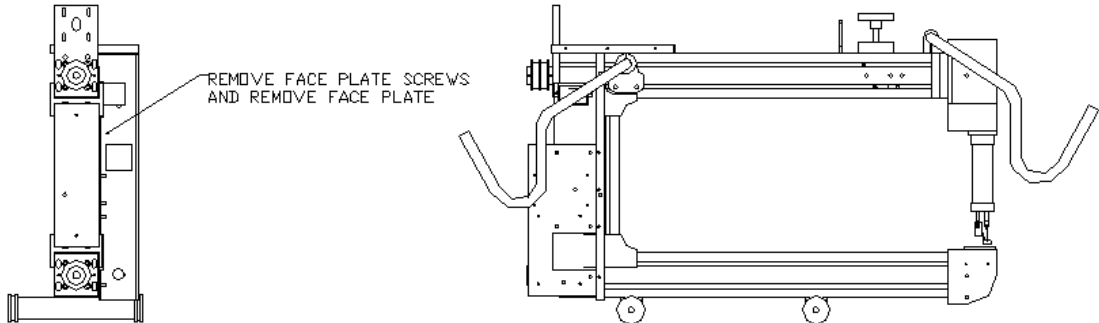

- 7) Connect the touch screen power cable and 9 pin serial cable to the side of the touchscreen. Make sure to note which wire, #1 or #2, of the gray power cable goes to the (+) and (-) of the green plug.

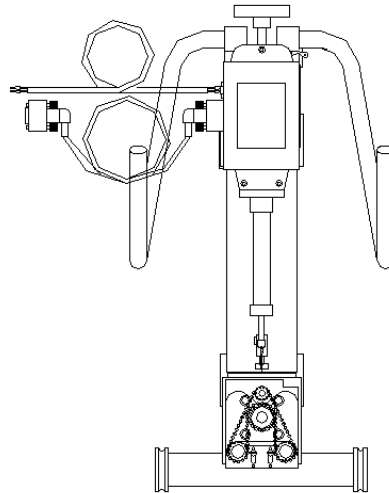

- 8) Route the power cable and 9 pin serial cable through the top slot of the left side of the upper beam. Trim about 1 inch off the white slot cover to allow for clearance around the wires. Re-install the trim piece.

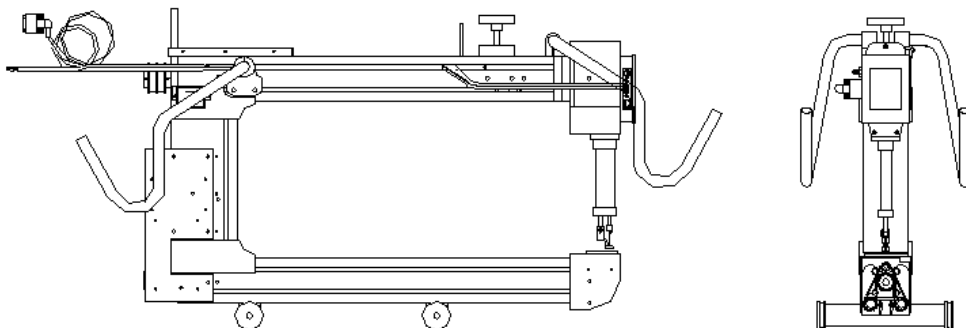

- 9) Re-install the side face plate making sure the power cable and 9 pin serial cable are not pinched by the plate. Lightly tap the square hole plug into the side face plate.

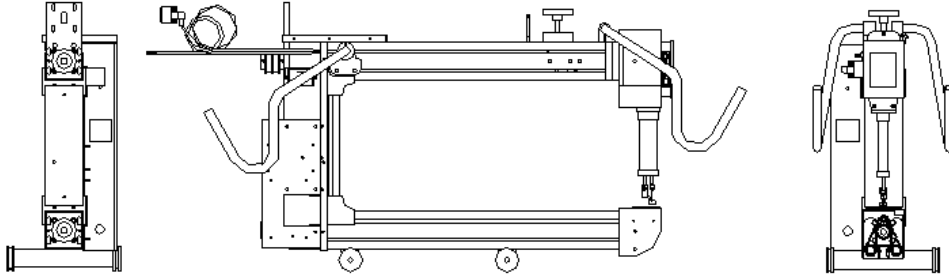

- 10) Install the Lightning Stitch motor and drive assembly using (1) M5 x 20mm SHCS, (1) lock washer and (2) flat washers per mounting hole. **YOU MUST USE THE (1) LOCK WASHER AND (2) FLAT WASHERS PER HOLE OR YOU MAY DAMAGE THE MOTOR ASSEMBLY!!**

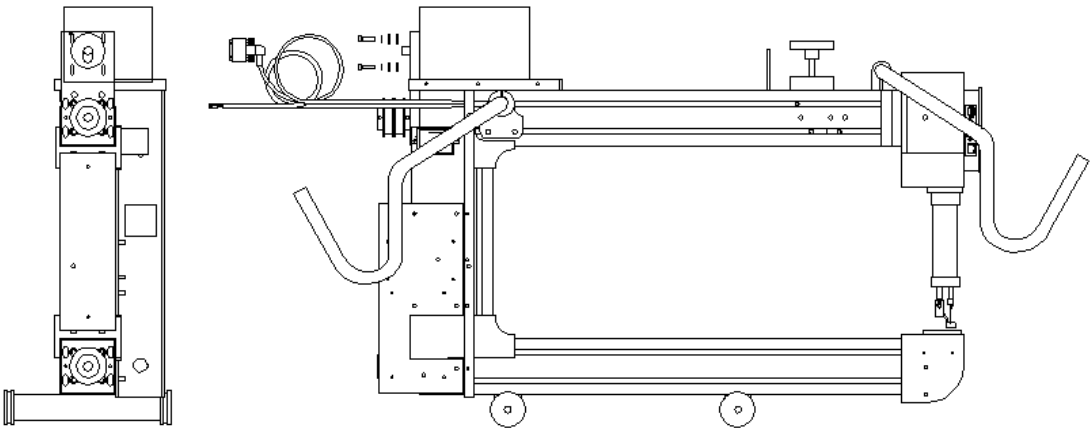

- 11) Remove the (4) Phillips head screws on the piggy backed board and carefully separate the two boards. Install the larger board onto the (4) brass standoffs at the bottom of the Innova. Use the original (4) screws that held the main control board on. Make sure that none of the cables or wires of the Innova are pinched behind the control board.

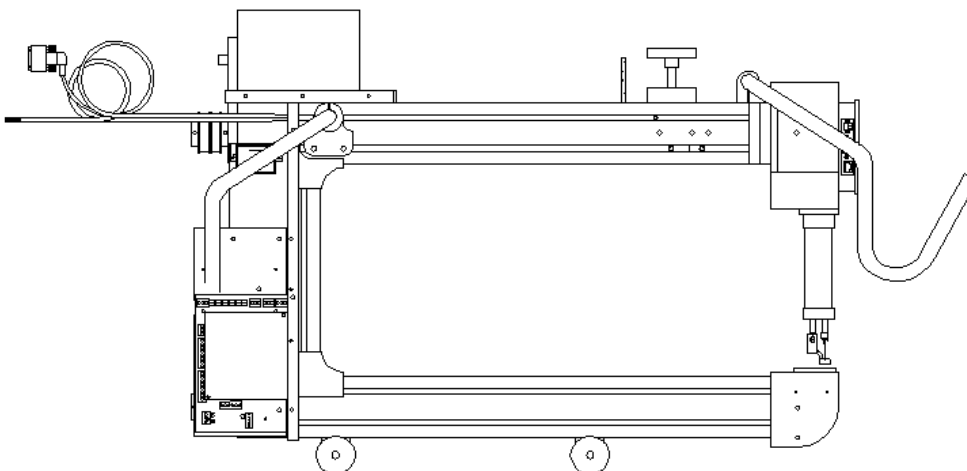

- 12) If needed, install the 6" pushbutton cable extension onto the pushbutton cable labeled R1. Using the (4) Phillips head screws, install the smaller piggy backed board onto the lower board. Make sure the all of the pins engage their corresponding sockets to make proper connection between the upper and lower board. Also make sure the 3 wire power plug from the lower board is plugged into the upper board. Be sure to re-install the protective UL paper insulator on top of the piggy backed board assembly.
- 13) Connect the main power switch, pushbuttons, laser and laser switch to the controller board.

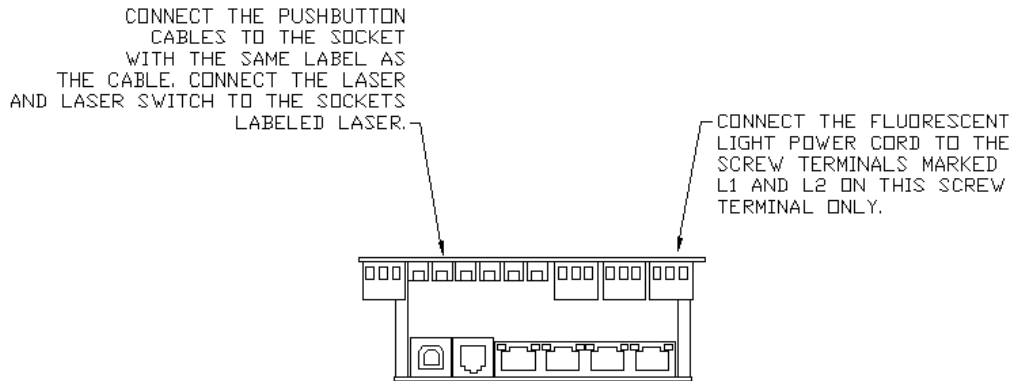

- 14) Connect the communication cable to the motor drive assembly and the control board. The communication cable for the lightning stitch motor must plug into the socket closest to the phone jack on the controller (SEE ILLUSTRATION ON STEP 15)

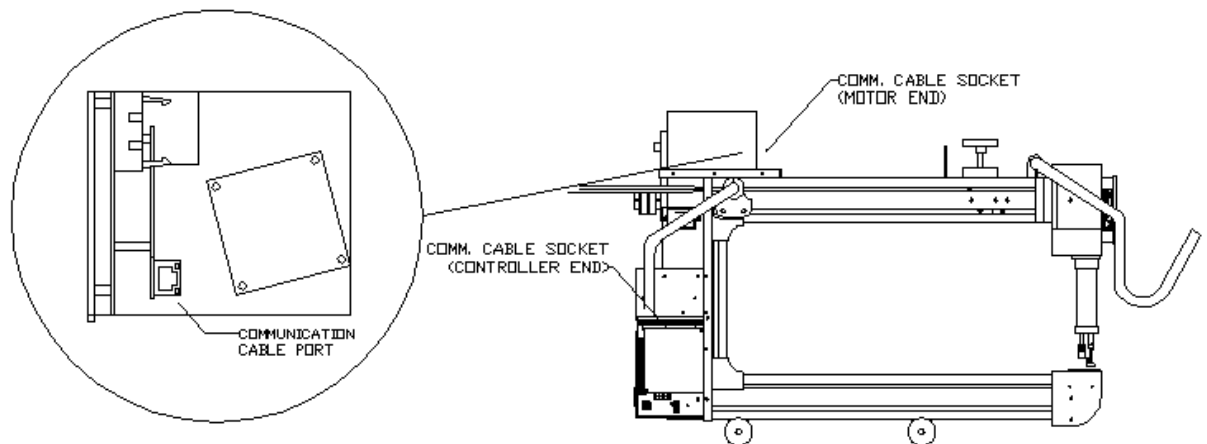

- 15) Connect the motor power cable to the motor. Confirm that the communication cable is plugged into the socket closest to the phone jack.

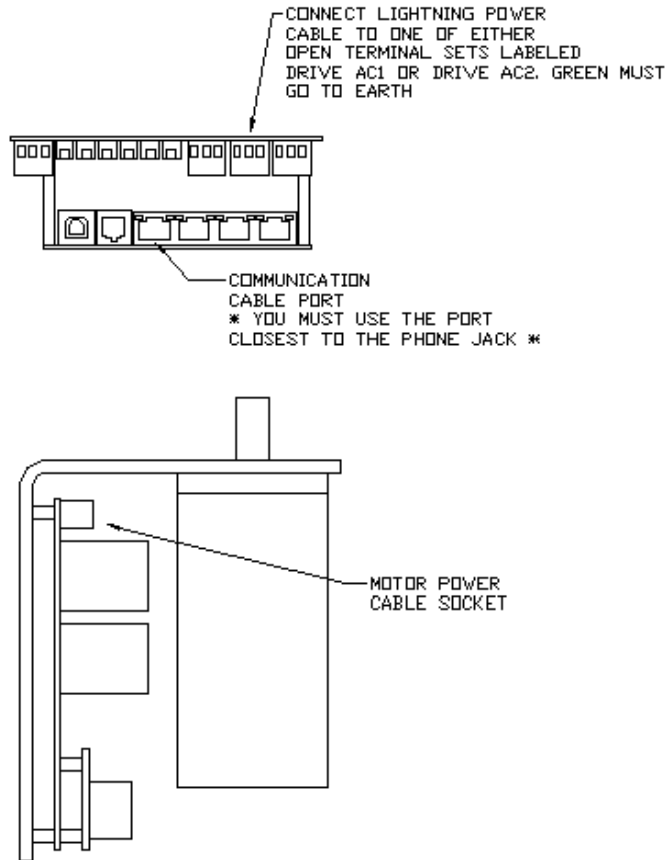

- 16) Remove the (2) thumbscrews from the 9 pin adapter and phone cord assembly.

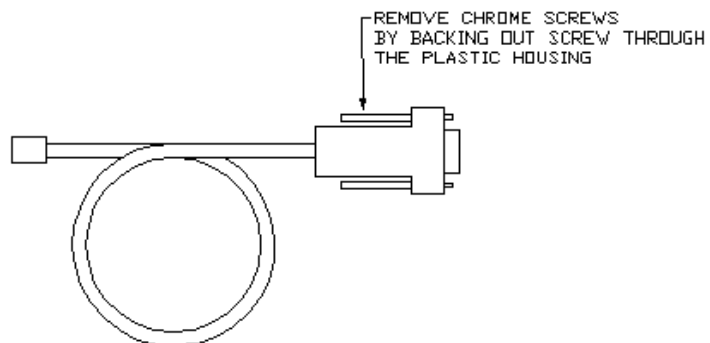

- 17) Connect the 9 pin adapter to the 9 pin Serial cable and hold connection together with (2) nylon ties installed as illustrated.

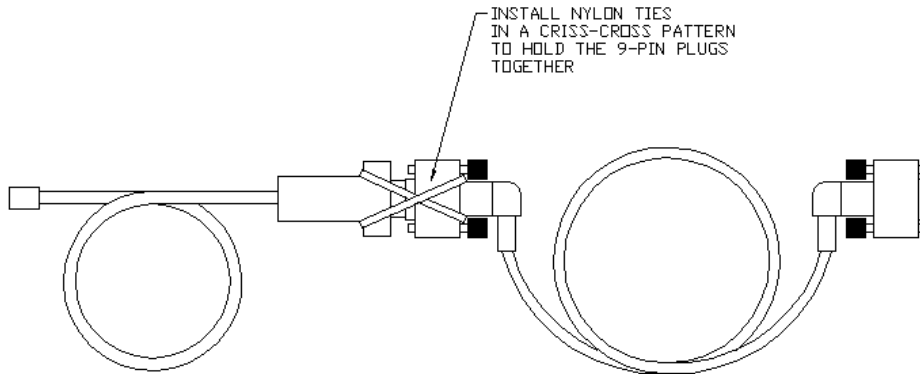

- 18) Connect the touch screen power cable to the controller board. Make sure to connect the correct numbered wire, 1 or 2, to the 24V (+) and GND (-) terminal of the board. Plug the phone cord into the phone jack.

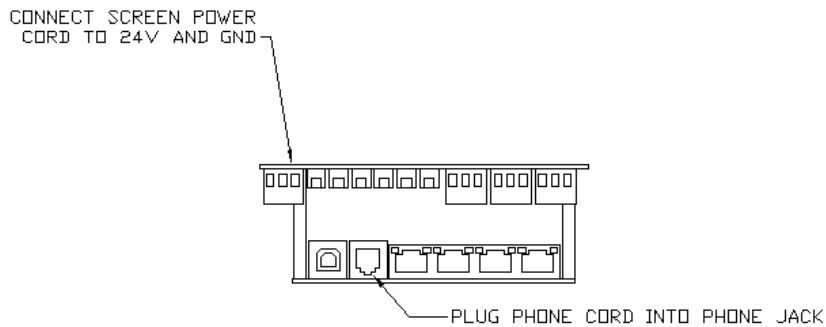

- 19) Using the supplied wiring diagrams, connect the encoder cables and power cord to the Innova.
- 20) Wire tie all of the loose wires in and make sure that none of the wires will rub against moving parts – specifically the pulleys and rubber timing belts.

CAUTION!!!

THE NEXT STEP WILL REQUIRE THE POWER TO BE ON WITH COVERS REMOVED. TURN OFF THE POWER AND UNPLUG THE MACHINE IF ADJUSTMENTS NEED TO BE MADE DURING THE VISUAL POWER UP INSPECTION. DO NOT TOUCH ANY PART OF THE ELECTRONICS WITH THE POWER ON.

- 21) While standing at the back end of the machine, plug the machine in and turn ON the power switch. The RED, YELLOW and GREEN LEDs of the controller board should illuminate for a few seconds. The RED and YELLOW LED should turn OFF and the GREEN LED should remain ON.

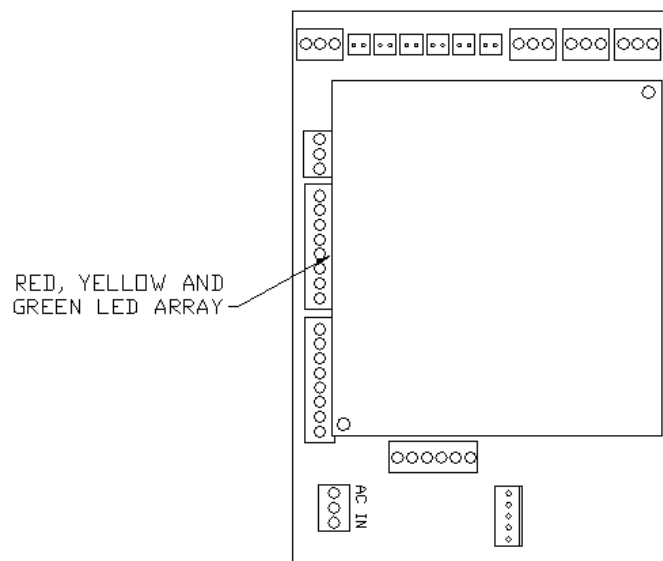

- 22) Check to make sure the LED on the socket of the communication cable is GREEN.

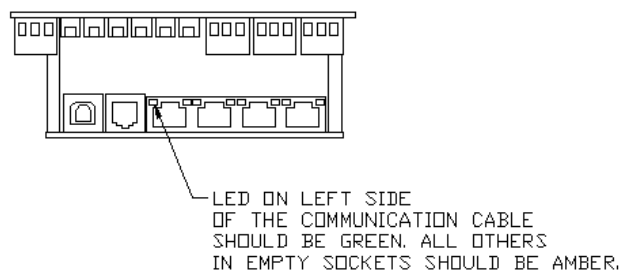

- 23) Check to make sure the LED on the motor drive assembly is flashing and the LED on the communication cable socket of the motor is GREEN.

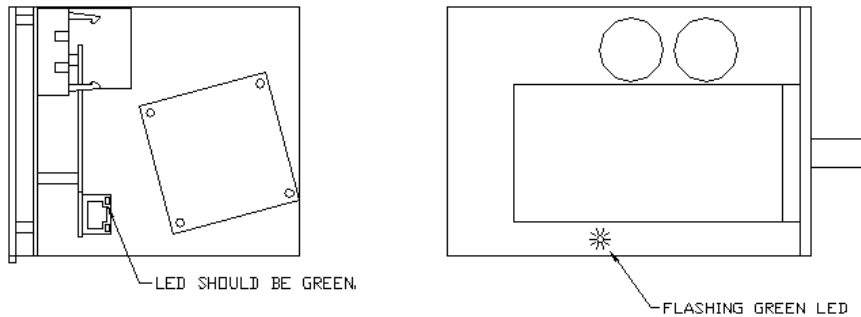

- 24) Make sure the touch screen powers up and loads into the Lightning Stitch user interface. This may take a minute to load from the time the machine is turned ON.
- 25) Turn OFF the machine and unplug it from the power source. Re-install the top motor cover and rear cover.

3.0 Lightning Stitch Troubleshooting

This section is divided into four parts, general troubleshooting, LMC controller troubleshooting, MDA drive trouble shooting and fault codes.

General Troubleshooting:

PROBLEM	POSSIBLE SOLUTION
Machine does not turn ON	<p>Check to make sure machine is plugged into a working outlet</p> <p>Check to make sure the main power switch is in the ON (I) position</p> <p>Check to make sure the main power switch plug is connected to the lower controller board</p> <p>Check to make sure the main power cord is connected to the screw terminals of the controller board. With white, black and green going to the correct terminal</p>
Touchscreen does not turn ON but white and green buttons work	<p>Check to make sure power cable is plugged into the side of the touchscreen</p> <p>Check to make sure power cable is connected to the screw terminals 24V and GND of the controller board.</p> <p>Check to make sure the polarity of the power cable is correct - (+) of the touchscreen to 24V of the controller and (-) of the touchscreen to GND of the controller.</p>
Touchscreen turns ON but white and green buttons do not work.	<p>Check to make sure GREEN LED of the controller is ON and solid. If not, CALL ABM.</p> <p>Check to make sure buttons are plugged into the controller board.</p> <p>Check to make sure the pins of the piggy backed board assembly are connected to the lower board.</p> <p>Check to make sure the 3 wire power cord of the piggy backed board assembly is connected to the upper and lower board.</p> <p>Call ABM.</p>
Green buttons do not work, but white buttons work	<p>If equipped with an AUTOPILOT, the AUTOPILOT control box must be ON during all operations of the INNOVA.</p> <p>Check to make sure buttons are plugged into the controller board.</p> <p>Check to make sure the pins of the piggy backed board assembly are connected to the lower board.</p> <p>Check to make sure the 3 wire power cord of the piggy backed board assembly is connected to the upper and lower board.</p> <p>Call ABM.</p>

Touchscreen turns ON with a
COMMUNICATION FAULT

Press OK to clear. If fault goes away resume use.

Check the 9 pin serial cable connector on the side of the
touchscreen - unplug and replug

Check the 9 pin serial cable to adapter connection

Check the phone cord to 9 pin adapter connection

Check the phone cord to controller phone jack connection

Call ABM.

Touch screen has a FAULT message

Press OK to clear. If fault goes away resume use.

Check for machine jam. Turn the machine by hand using the
handle. Make a few complete turns of the machine to check for
any jams.

Remove motor cover and check the motor status LED. Record the
number of GREEN and RED flashes if applicable. See LED fault
determination table. Call ABM.

Call ABM.

Control board RED or YELLOW LEDs are
flashing

See LMC LED fault determination

Call ABM.

Motor assembly LEDs flash a sequence
of RED and GREEN

See MDA LED fault determination

Call ABM.

Communication socket on motor or
control board is AMBER or flashes
between GREEN and AMBER

Check communication cable connection - unplug and replug

Check communication cable for broken or abraded cable.

Call ABM.

LMC Controller Troubleshooting:

CONTROLLER STATUS:

CODE	DESCRIPTION	LED STATUS
	POWER UP BOOT STATUS	RED / GREEN / YELLOW SOLID
	SYSTEM RESET / NO PROGRAM LOADED	YELLOW FLASHING
	PROGRAM LOADED / NOT RUNNING	GREEN FLASHING
	PROGRAM RUNNING	GREEN SOLID
	MEMORY CLEAR IN PROGRESS	RED SOLID

CONTROLLER WARNINGS:

CODE	DESCRIPTION	LED STATUS
21	DIVIDE BY ZERO	2 YELLOW FLASHES / 1 GREEN FLASH
22	ILLEGAL ARGUMENT	2 YELLOW FLASHES / 2 GREEN FLASH
23	DEVICE WRONG STATE	2 YELLOW FLASHES / 3 GREEN FLASH
24	ACCESS OUTSIDE MEMORY	2 YELLOW FLASHES / 4 GREEN FLASH
25	RESERVED FOR FUTURE USE	2 YELLOW FLASHES / 5 GREEN FLASH
26	RESERVED FOR FUTURE USE	2 YELLOW FLASHES / 6 GREEN FLASH
27	RESERVED FOR FUTURE USE	2 YELLOW FLASHES / 7 GREEN FLASH
28	RESERVED FOR FUTURE USE	2 YELLOW FLASHES / 8 GREEN FLASH
29	RESERVED FOR FUTURE USE	2 YELLOW FLASHES / 9 GREEN FLASH
31	USB PORT TIMEOUT	3 YELLOW FLASHES / 1 GREEN FLASH
32	RS-232 PORT TIMEOUT	3 YELLOW FLASHES / 2 GREEN FLASH
33		3 YELLOW FLASHES / 3 GREEN FLASH
34		3 YELLOW FLASHES / 4 GREEN FLASH
35	USB PORT ILLEGAL PACKET CODE	3 YELLOW FLASHES / 5 GREEN FLASH
36	RS-232 PORT ILLEGAL PACKET CODE	3 YELLOW FLASHES / 6 GREEN FLASH
37	USB PORT PRINT QUEUE FULL	3 YELLOW FLASHES / 7 GREEN FLASH
38	RS-232 PORT PRINT QUEUE FULL	3 YELLOW FLASHES / 8 GREEN FLASH
39	RESERVED FOR FUTURE USE	3 YELLOW FLASHES / 9 GREEN FLASH

MDA driver troubleshooting:

GREEN LED	RED LED	Description	REMEDY
OFF	ON	Firmware Flash Checksum Fail	Consult Factory
FLASHING	OFF	Drive Disable – Normal Operation	None
ON	OFF	Drive Enabled	None
OFF	OFF	This is a more complexed status sequence to signify a drive fault. The drive will momentarily flash both LEDs followed by a fault code. The Green will flash the 10's place first then the red will flash the 1's place. The fault code is the sum of the 10's place and the 1's place. If an LED does not flash for a place then that places value is 0. Fault code F01 would not flash the Green LED only the Red Led one time.	See Table of Fault Codes
ON	ON		
OFF	OFF		
FLASH 10's	OFF		
OFF	FLASH 1's		
OFF	OFF		
REPEAT	REPEAT		

Fault Codes:

FAULT CODE	DESCRIPTION	REMEDY
F01 Internal Power Module Error	Driver has detected the following: <ul style="list-style-type: none"> • Overcurrent • Overheat • Gate voltage drop 	Check if the motor wire (A/B/C) is shorted or grounded. Ambient temperature over 55° C. Indicates a fatal fault in the driver power stage. If motor wires are not shorted and temperature is below 55° C, contact IIS factory.
F02 Overvoltage	DC power bus exceeds max. bus voltage.	Power line voltage fluctuation above maximum. 264 VAC for ESD-XX/A style drives. 528 VAC for ESD-XX/C style drives. Excessive regeneration energy. Check line voltage fluctuations. Add additional external regeneration resistor.
F03 Under Voltage	DC power bus below min. bus voltage.	Power line voltage fluctuation below minimum. 170 VAC for ESD-XX/A style drives. 352 VAC for ESD-XX/C style drives. Check line voltage fluctuations. Check for missing phase of AC line power.
F07 Power Stage Error F10 Regen Resistor Open	Main control unit does not recognize the power stage of the driver. Regen transistor is ON for more than 50ms.	Indicates a fatal fault in the driver power stage. Contact IIS factory. WITH POWER OFF FOR 5 MINUTES: verify with an ohm meter that the regen resistor is the proper value and that all wiring to the resistor is secure.
F15 Excessive Current	Motor current exceeds the rating by 120%.	Check if the motor wire (A/B/C) is shorted or grounded. Verify that motor shaft or machine system is not jammed. Check that the proper motor parameters have been sent to the drive.
F16 Speed amp Saturated	Internal speed loop is saturated and max.torque is applied for more than 3 sec.	Verify that motor shaft or machine system is not jammed. Check that the proper motor parameters have been sent to the drive. Acel/decel rate is too large for the inertia load on the motor causing maximum torque during acel/decel.

FAULT CODE	DESCRIPTION	REMEDY
F25 Option	Self-diagnostic checks of options failed or wrong option card installed.	Option card configured in program does not match installed option card. Option card not functioning to specification. Return to factory.
F40 Encoder Signal Short	U, V or W phases of encoder not functional.	Check encoder cable and connections.
F50 Store Parameters to Flash	An application parameter change has been made that requires the parameters to be saved to flash.	Parameters that require saving to non-volatile memory before they will take effect: PWM switching frequency (IDN 0022) See IDN #0049 for How to save to flash.
F51 Unsupported PWM Frequency	Drive has been configured to operate at a PWM Frequency not supported.	Change PWM Frequency (IDN 0022) to a valid frequency for drive.
F70 Following Error	Motor is not following the command	Check monitoring window (IDN 0115). Check for binding in mechanical travel of motor.
F72 Non-Volatile Parameter Failure	Non-Volatile calibration data has been lost.	Contact IIS Factory.
F74 Encoder Phase Error	Encoder A or B tracks are out of phase with U track.	Check encoder wiring. Make sure there are no loose connections. Make sure encoder cable is separated from any high-power wiring.
F75 W-Phase Over-Current	W-phase current exceeds the rating by 120%.	Check if the motor wire (A/B/C) is shorted or grounded. Verify that motor shaft or machine system is not jammed. Check that the proper motor parameters have been sent to the drive.
F80 Communication Error From Luminary Controller	Drive has detected at least 2 consecutive Cyclic Master Communication Packets in the communication from the controller	Check For Factory Specified Communication Cable. Verify proper grounding on controller and drive. Replace Communication Cable if necessary.
F86 Invalid Operation Mode	A request was made to switch to an invalid operation mode.	Check for a programming error.

* Indicates a fault that can only exist when the drive is configured for SERCOS communications.

ABM International, Inc.

Lightning Stitch Checklist

9/13/2013

- 1) Piggy backed board assembly (1)

Piggy back board assembly tested?	Yes	No
24v passed		
XB passed		
XA passed		
YB passed		
YA passed		
SAFE passed		
S/S passed		
- 2) Motor & board assembly (1)

Motor and board assembly tested?	Yes	No
----------------------------------	-----	----
- 3) Touch screen computer (1)

Programmed?	Yes	No
-------------	-----	----
- 4) M5 x 20mm SHCS bolts (4)
- 5) #10 SAE flat washer (8)
- 6) #10 lock washer (4)
- 7) 6" Push button extension cable (1)
- 8) 9-pin to phone cord adapter (1)
- 9) Phone cord (1)
- 10) 1ft. Network communication cable (1)
- 11) 9-pin serial communication cable (1)
- 12) 2-conductor touch screen power cable (1)
- 13) Square plug for PLC knockout (1)
- 14) Bag of 4" wire ties
- 15) 3mm x 14mm bolt (4) (for clear plastic face plates)
- 16) Wiring diagram
- 17) Touch screen mounting hole template or drawing

Checked by:

Date:

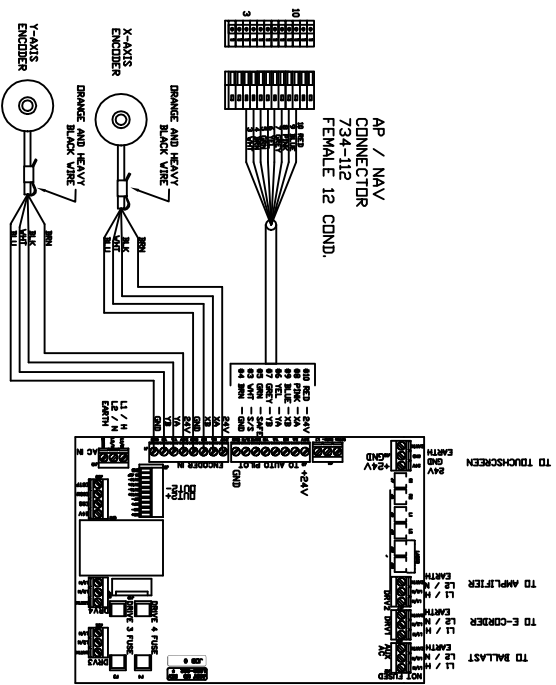
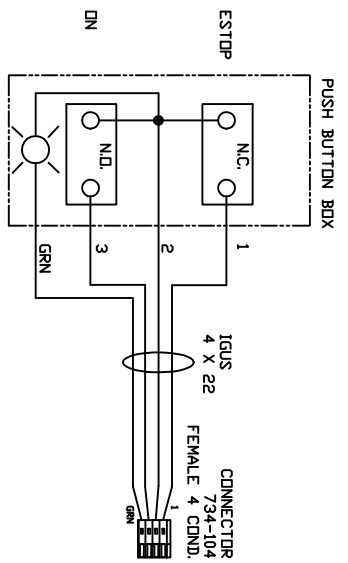

NYLON TIE PLUG CONNECTION TOGETHER. REMOVE METAL PC PLUG SCREWS AND DISCARD.

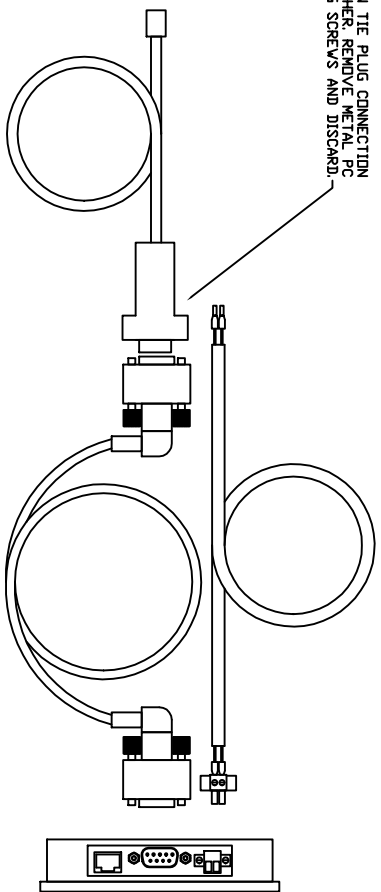

INCHES			
UNLESS OTHERWISE SPECIFIED			
<small>ALL DIMENSIONS ARE IN INCHES ALL DIMENSIONS ARE TO FACE UNLESS OTHERWISE SPECIFIED ALL DIMENSIONS ARE TO CENTER UNLESS OTHERWISE SPECIFIED ALL DIMENSIONS ARE TO BE TAKEN FROM THE CENTERLINE UNLESS OTHERWISE SPECIFIED DIMENSIONS ARE TO BE TAKEN FROM THE CENTERLINE UNLESS OTHERWISE SPECIFIED DIMENSIONS ARE TO BE TAKEN FROM THE CENTERLINE UNLESS OTHERWISE SPECIFIED DIMENSIONS ARE TO BE TAKEN FROM THE CENTERLINE UNLESS OTHERWISE SPECIFIED DIMENSIONS ARE TO BE TAKEN FROM THE CENTERLINE UNLESS OTHERWISE SPECIFIED DIMENSIONS ARE TO BE TAKEN FROM THE CENTERLINE UNLESS OTHERWISE SPECIFIED</small>			
ABM INTERNATIONAL			
<small>ABM INTERNATIONAL, Inc. 311 SHERBOURNE AVENUE ELA DORNE, MARYLAND, U.S.A. 20637</small>			
<small>TITLE: INNOVA TO AP/NAV CONTROL BOX FOR LIGHTNING SWITCH INNOVA</small>			
<small>DRAWN BY: JOE PODOLSKI DATE: 1/30/13</small>			
<small>CHECKED BY:</small> PNO SHEET NO. 1	<small>SCALE:</small> NONE	<small>DRAWING NO.:</small> E-PNO-001D	<small>DATE:</small> -

AP / NAV
CONNECTOR
734-112
FEMALE 12 COND.

10	0	0	0	0	0	0	0	0	0	0	0
9	0	0	0	0	0	0	0	0	0	0	0
8	0	0	0	0	0	0	0	0	0	0	0
7	0	0	0	0	0	0	0	0	0	0	0
6	0	0	0	0	0	0	0	0	0	0	0
5	0	0	0	0	0	0	0	0	0	0	0
4	0	0	0	0	0	0	0	0	0	0	0
3	0	0	0	0	0	0	0	0	0	0	0



#10	RED	-	24V
#8	PINK	-	XA
#9	BLUE	-	XB
#6	YEL	-	YA
#7	GREY	-	YB
#5	GRN	-	SAFE
#3	WHT	-	S/S
#4	BRN	-	GND

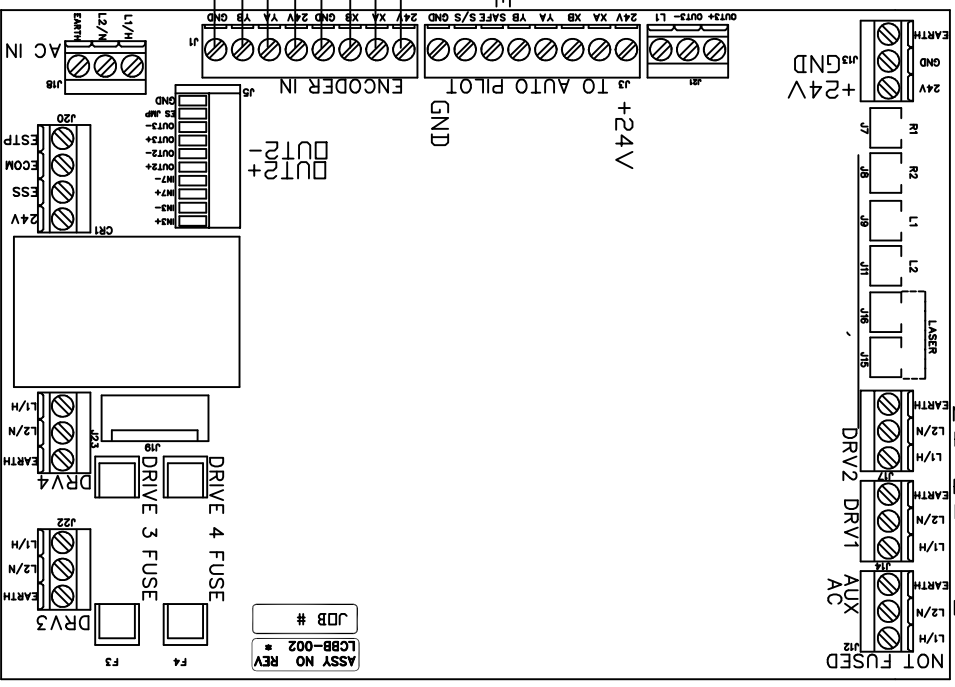
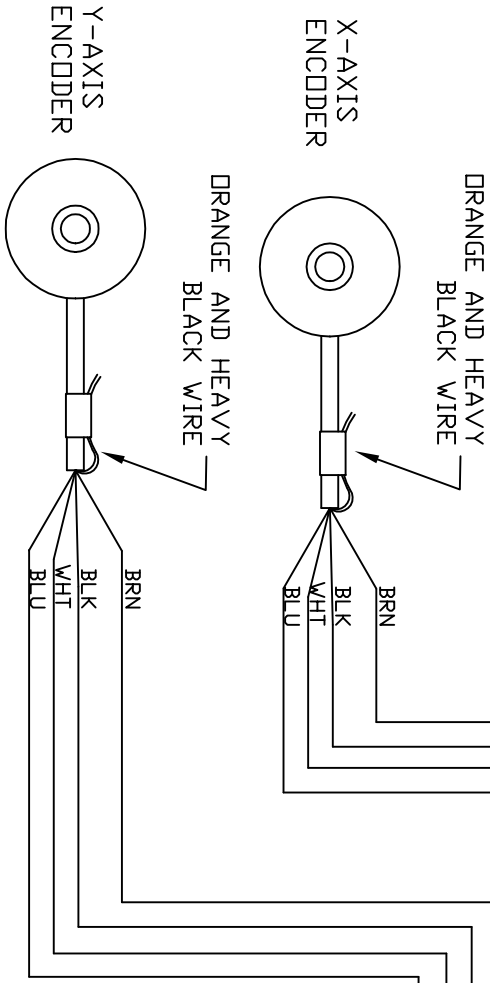

TO TOUCHSCREEN
TO AMPLIFIER
TO E-CORDER
TO BALLAST

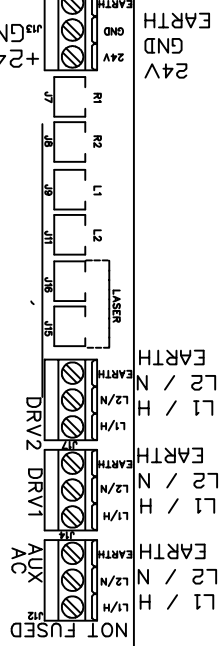

WARNING:

DO NOT USE TEMPLATE IF SCALE BELOW
DOES NOT MEASURE 3 INCHES EXACTLY.

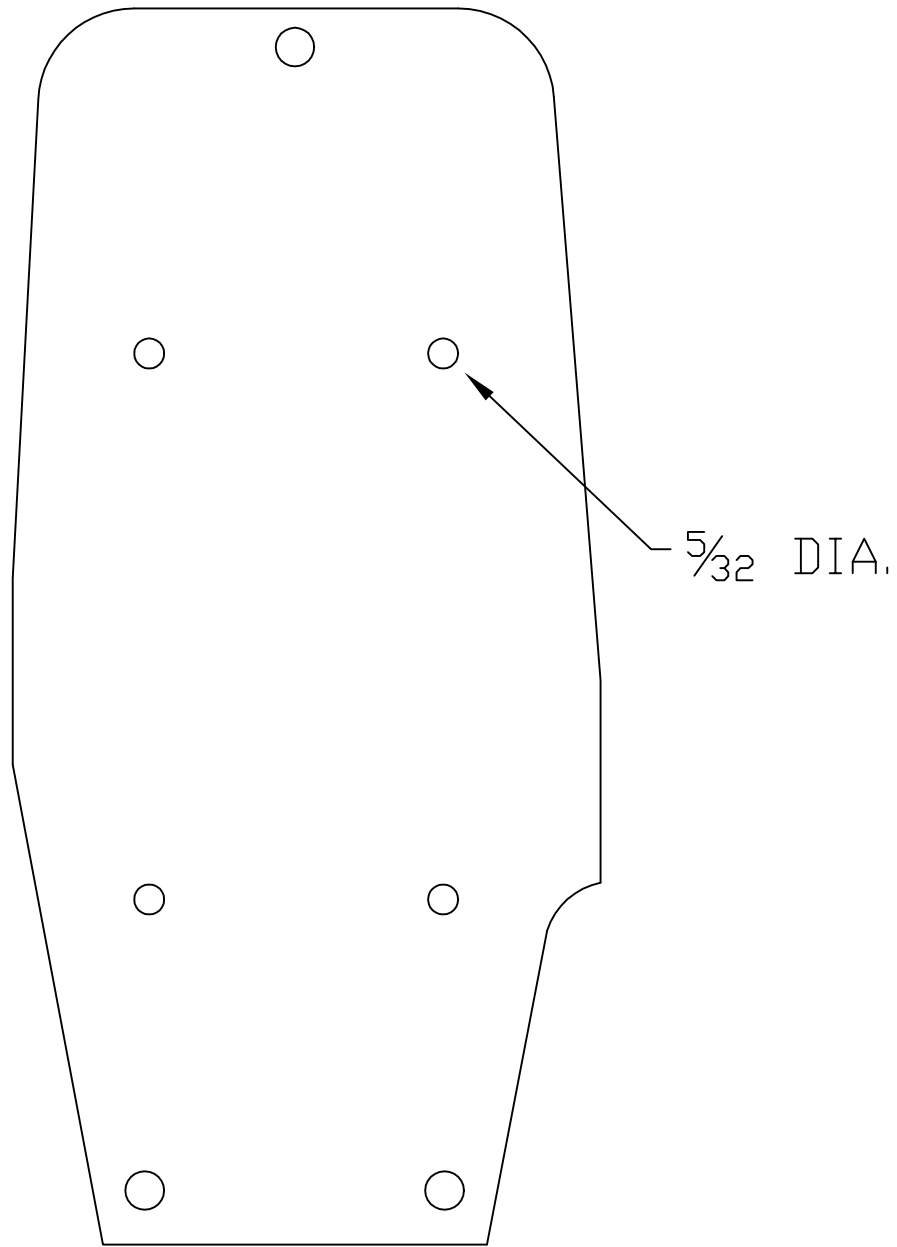
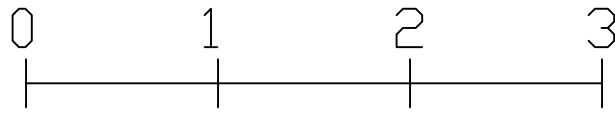

SCREEN MOUNTING
HOLE TEMPLATE