









HOT  
FROM: SH 1

NEUT  
FROM: SH 1

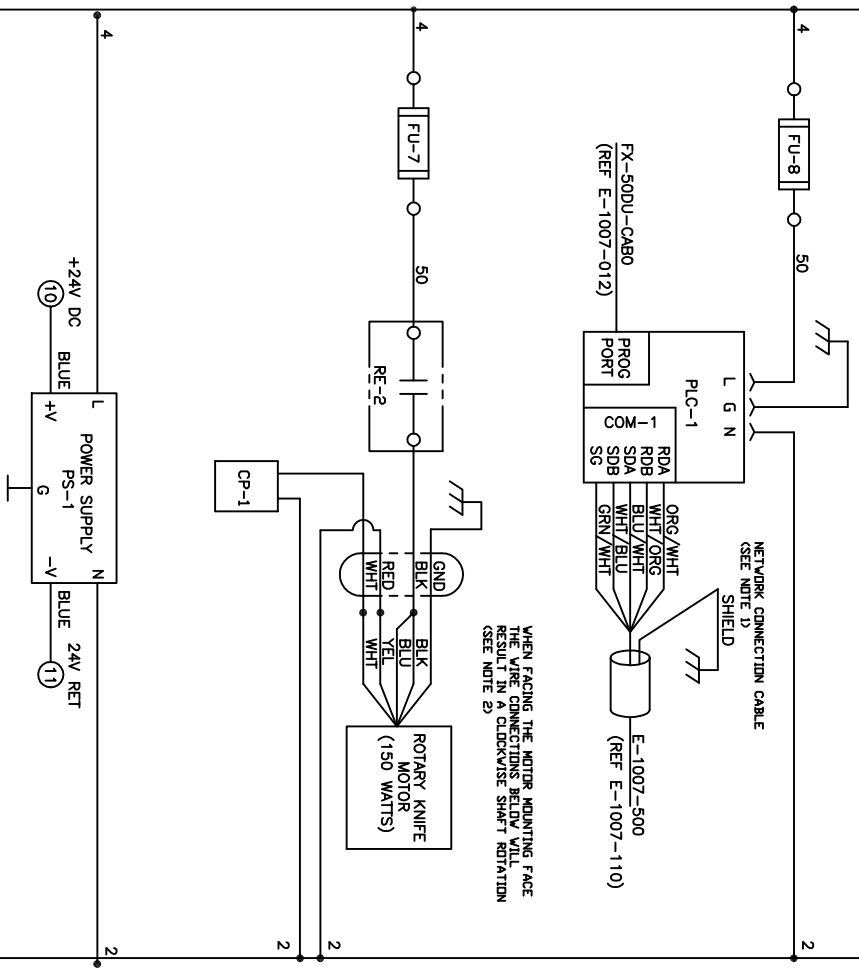

WHEN FACING THE MOTOR MOUNTING FACE  
THE WIRE CONNECTIONS BELOW WILL  
RESULT IN A CLOCKWISE SHAFT ROTATION  
(SEE NOTE 2)

NETWORK CONNECTION CABLE  
(SEE NOTE 1)

FX-50DU-CABO  
(REF E-1007-012)

PLC-1  
L G N  
1 1  
RDA  
RDB  
SDA  
SDB  
SC

ORG/WHT  
WHT/ORG  
BLU/WHT  
WHT/BLU  
GRN/WHT

E-1007-500  
(REF E-1007-110)

ROTARY KNIFE  
MOTOR  
(150 WATTS)

GND  
BLK  
RED  
WHT  
BLU  
YEL  
WHT

CP-1

POWER SUPPLY  
PS-1  
+V  
-V  
G

NOTE 1: THERE ARE 2 (230 OHM) RESISTORS NOT SHOWN  
IN THE ORIGINAL DRAWING. THESE RESISTORS  
CONNECT RDA AND RDB, SDA AND SDB.  
NOTE 2: WHEN FACING THE MOTOR MOUNTING FACE  
THE WIRE CONNECTIONS BELOW WILL  
RESULT IN A COUNTER CLOCKWISE SHAFT ROTATION

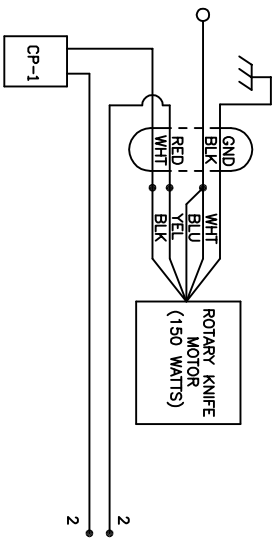

ROTARY KNIFE  
MOTOR  
(150 WATTS)

CP-1

INCHES  
UNLESS OTHERWISE SPECIFIED

ABM INTERNATIONAL

ABM INTERNATIONAL, Inc.  
BLK BONE VALVE, L 0007

BMT CUTTER  
AND FILLER

DATE: 2-29-00  
DRAWN BY: SCOTT WILL  
CHECKED BY: DOZ  
REVISION NO. 1

DATE: 2-29-00  
DRAWN BY: SCOTT WILL  
CHECKED BY: DOZ  
REVISION NO. 1  
E-1007-011





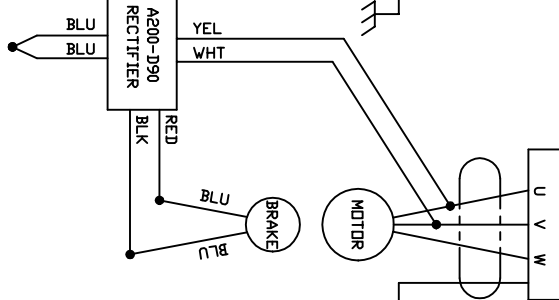
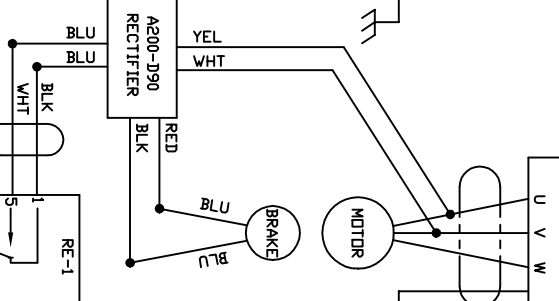
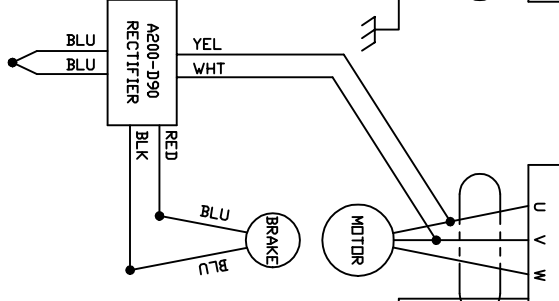
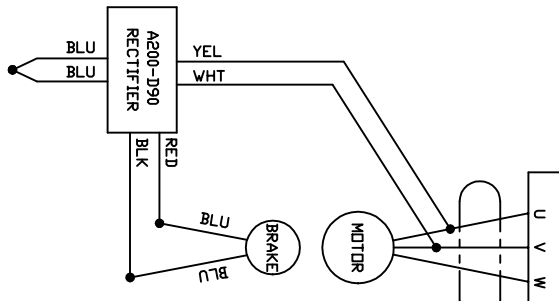
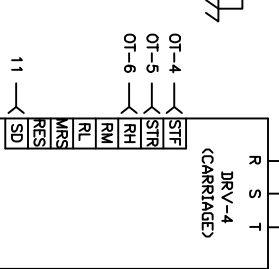
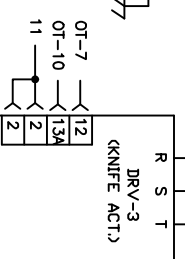
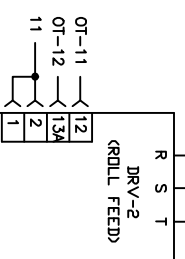
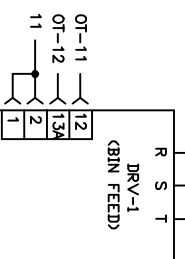

**INCHES**  
UNLESS OTHERWISE SPECIFIED.

ABM INTERNATIONAL  
5414 INTERNATIONAL BLVD.  
BAY BRIDGE, VA 22007

BATT CUTTER  
AND FILER

DATE: 2-29-00

ISSUED BY: SCOTT WILL

ISSUE NO: NONE

1 1 E-1007-013A

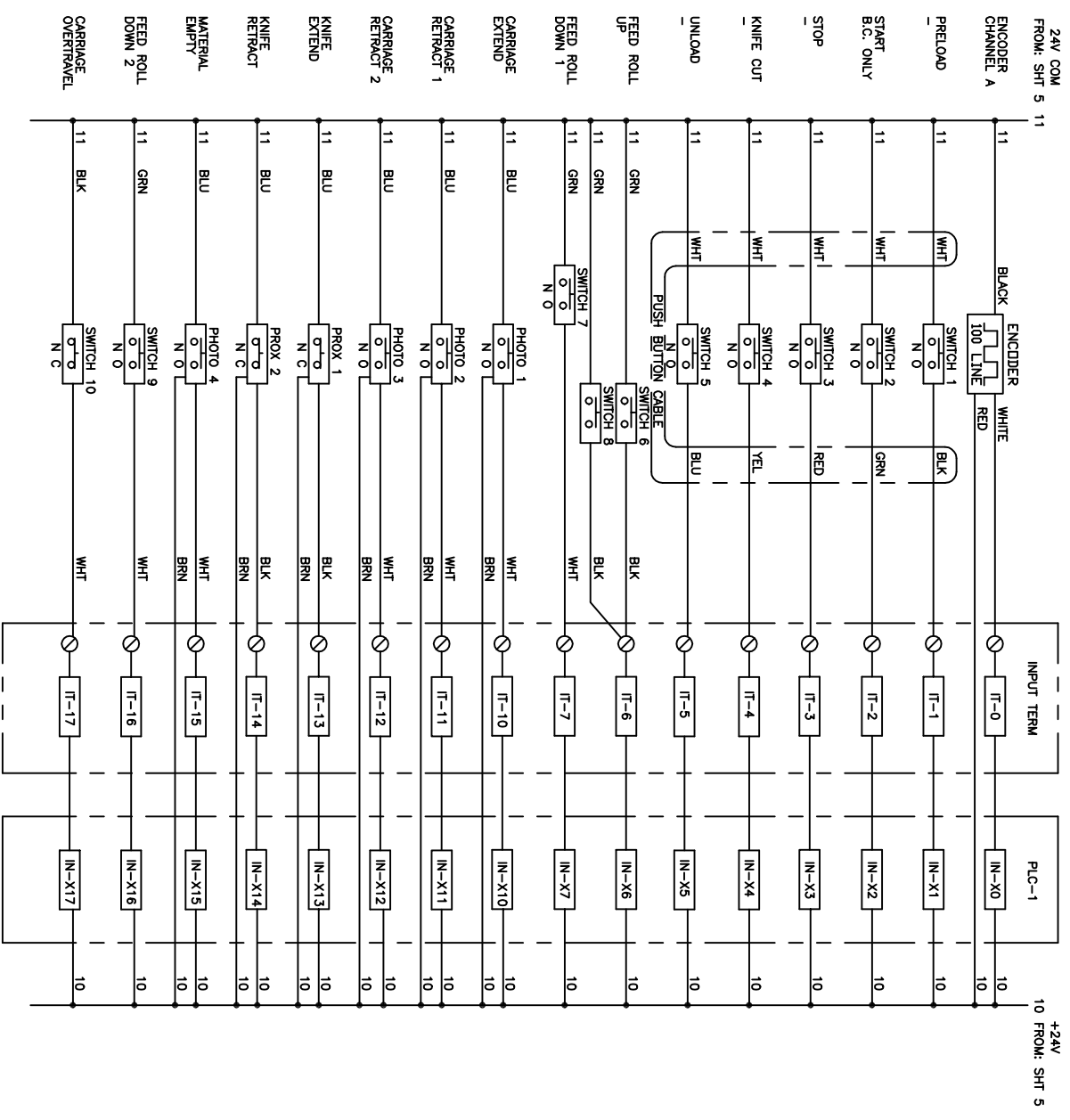

NOTES:  
 1) HIGH OFF-STATE VOLTAGES MUST BE SHUNTED WITH A 1K OHM 1 WATT RESISTOR.  
 2) DIODE IS REQUIRED FOR INDUCTIVE LOADS.

**INCHES**

UNLESS OTHERWISE SPECIFIED

ABM INTERNATIONAL  
 ABAK INTERNATIONAL, Inc.  
 616 BROWN VALLEY, IL 60007

BAT CUTTER  
 AND FILTER

DATE: 2-29-00

DESIGNED BY: SCOTT WILL

REVISED BY: 007

ISSUED BY: 1

DATE: 1

REVISION NO: E-1007-014









