

ABM International, Inc.

Cross Hatch Ruler Bar

1.0: Parts List

Ruler bar (Qty. 1)

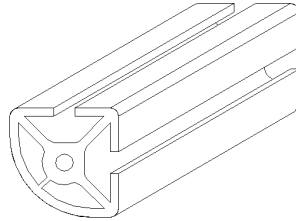

Ruler bar bracket (Qty. 2)

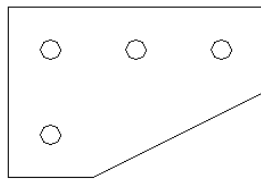

Ruler bracket (Qty. 1)

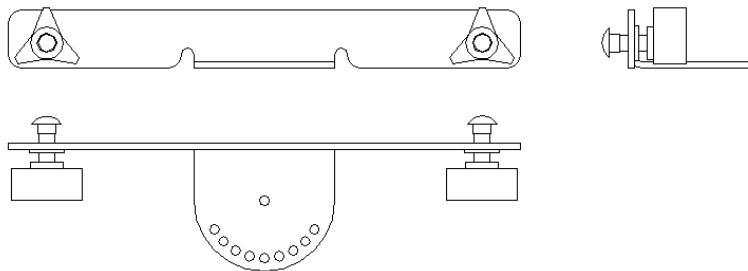

Ruler (Qty. 1)



Ruler locking knobs (Qty. 2)

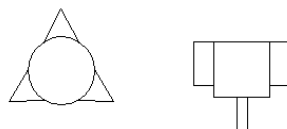

Bolt kit –

Hex head cap screw:



(Qty. 4) 5/16 x 3/4

Flat washers:



(Qty. 4) 5/16

Lock washers:



(Qty. 4) 5/16

2.0 Cross hatch ruler bar assembly

Step 1: Remove the take-up and idler rollers and support collars from the frame.

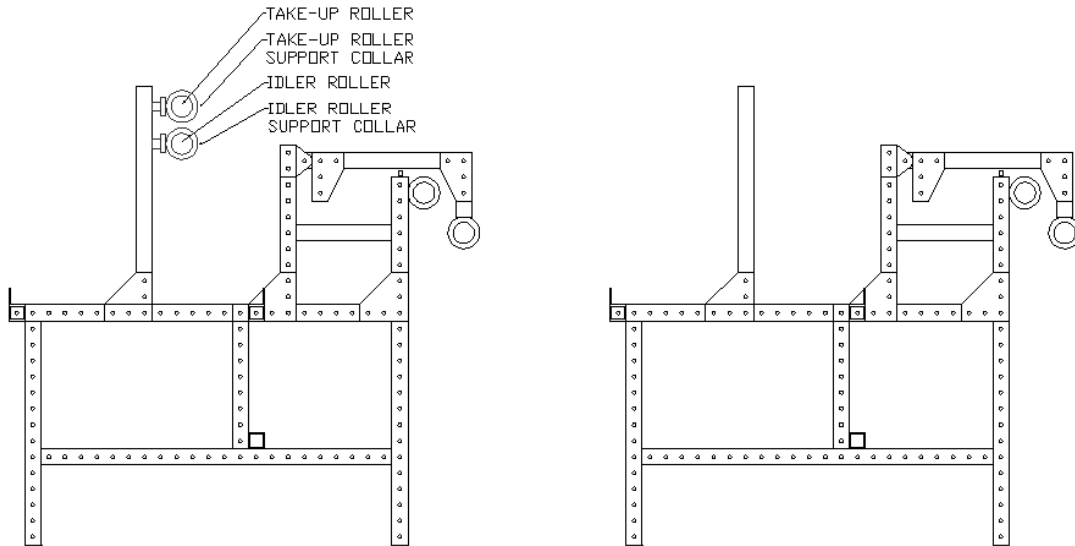

Step 2: Install the (2) ruler bar brackets on the slotted beams using (1) 5/16 x 3/4 Hex, (1) 5/16 lock washer and (1) 5/16 flat washer.

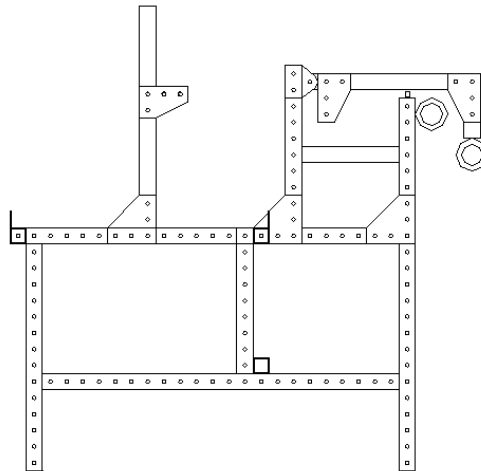

Step 3: Slide the ruler bracket onto the ruler bar as illustrated below.

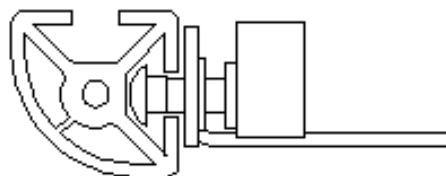

Step 4: Install the ruler bar onto the ruler bar brackets using (1) 5/16 x 3/4 hex, (1) 5/16 lock washer and (1) 5/16 flat washer on each end.

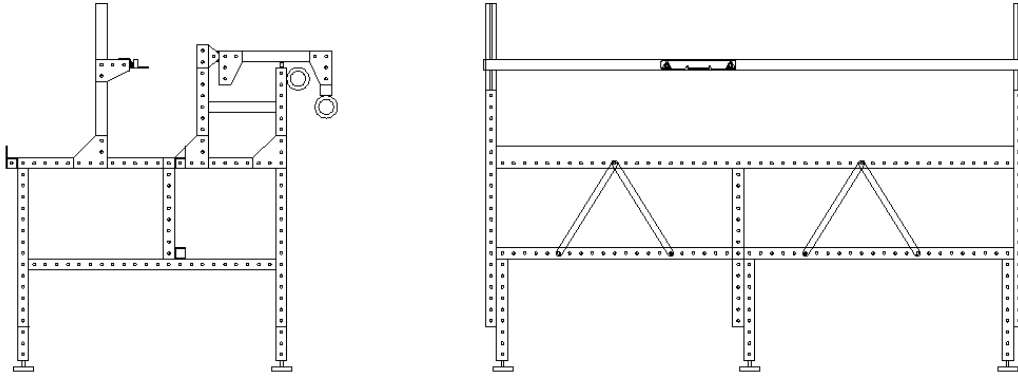

Step 5: Re-install the take-up support collars and roller onto the machine.

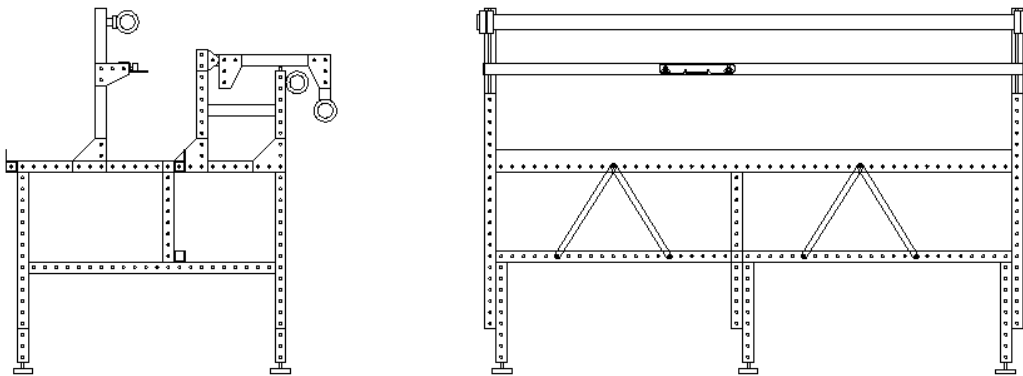

Step 6: Adjust the ruler bar height for adequate clearance from the bed of the quilting machine.

Step 7: Check to make sure the take-up roller and ruler bar are parallel to each other and the frame.

3.0 Operation

The cross hatch ruler bar allows the user to slide the ruler left and right to any position along the length of the frame as well as set the angle of the ruler in 15° increments.

Adjustment left to right:

1. Loosen the two locking knobs on the ruler bracket.
2. Slide the ruler to the desired position
3. Tighten the locking knobs

Adjustment of ruler angle:

1. Remove front locking screw in ruler
2. Align hole in ruler with hole in ruler bracket at desired angle
3. Re-install the locking screw. **DO NOT OVERTIGHTEN**

Removal of cross hatch ruler:

1. Remove the two locking knobs
2. Lift the cross hatch ruler bracket off of the studs
3. Slide stud to either end of the bar

Re-installation of the cross hatch ruler:

1. Install the cross hatch ruler onto the studs located in the ruler bar.
2. Install the 5/16 flat washer and locking knob onto each stud.

