

ABM International, Inc.
Innova Micro Handles

1.0: Parts List

Handle bar clamp (Qty. 2)

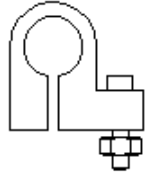

Handle bar clamp mount (Qty. 1)

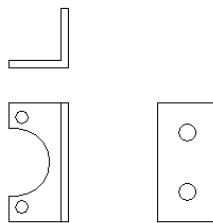

Grip (Qty. 2)

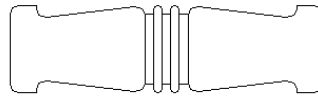

Handle bar (Qty. 2)

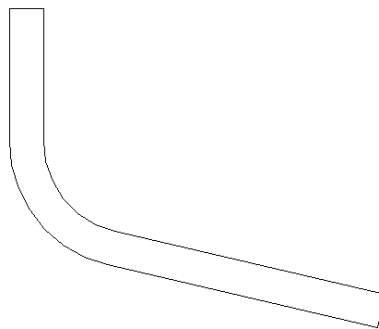

Socket head cap screw (Qty. 2)



2.0 Micro handle assembly

Step 1: Install the rubber grips onto the ends of the micro handle bars. Installing the grips onto the short ends will work for all machines except for an 18" or 22" with a touch screen mounted on the front faceplate. 18" and 22" machines equipped with touch screens should have the grips installed on the long ends. **NOTE: Using a silicon spray will help the grip slide easily onto the bar.**



Step 2: Install the handle bar clamps onto the clamp mount using the socket head screws and hex nuts include with the clamps. See the illustration below for proper orientation.

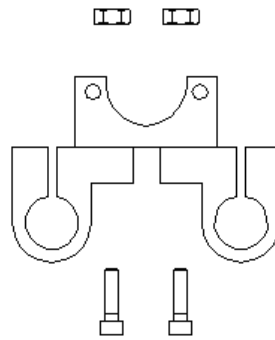

Step 3: Install the handle bars into the handle bar clamps. **NOTE: The bar clamps may be tight on the handle bars. To help with installation, lightly tap a flat blade screwdriver into the slot in the side of the bar clamp until the slot is pried open slightly. Do not pry excessively on the clamp or the unit may crack or fail entirely.**

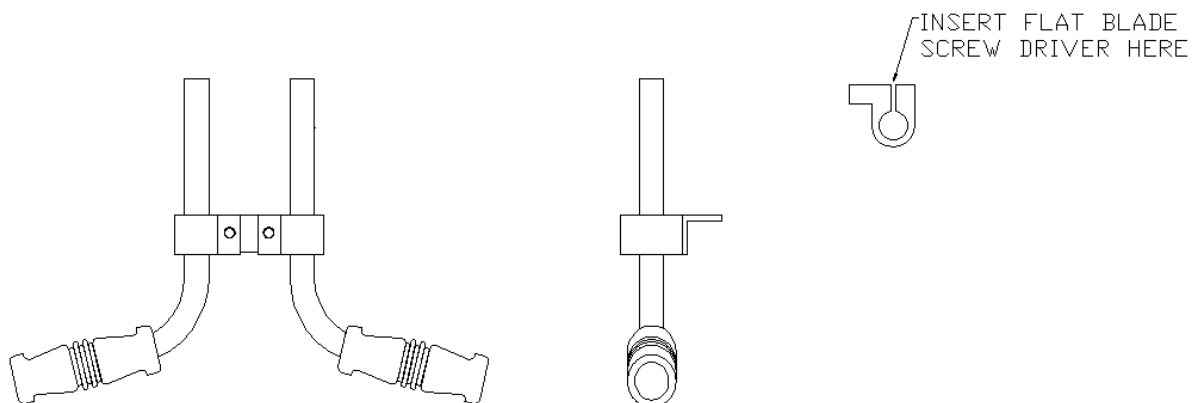

Step 4: Remove the (2) front needle bar bushing screws from the Innova.

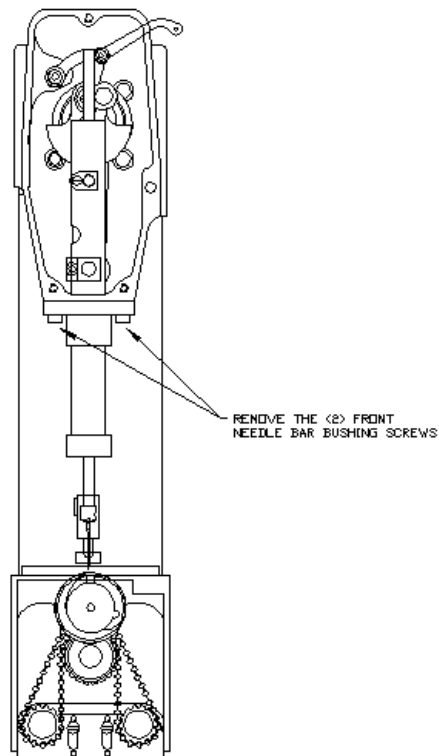

Step 5: Install the handle bar assembly onto the Innova using the longer socket head cap screws supplied with kit. **NOTE: Make sure that the needle bar bushing assembly does not slip during installation. To confirm this, the needle should pass through the center of the needle plate hole.**

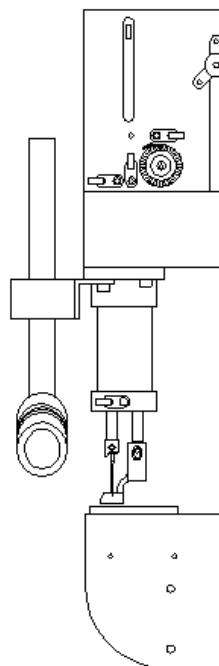

Step 6: Adjust the handle bars so that the micro handles are comfortable to hold. NOTE: The Innova Micro Handles are adjustable in three directions:

- 1) Height from the quilt
- 2) Grip angle with relation to the quilt (to reduce wrist strain)
- 3) Grip angle with relation to the user (to reduce wrist strain)

