

ABM International, Inc.
Model: Innova Longarm Quilting Machine

Series: All Innovas
PantoVision Installation

PANTOVISION Installation

ABM International, Inc.

Wiring the PantoVision blue box to the Innova:

Step 1: Turn OFF the machine and unplug it from the power outlet.

Step 2: Remove the rear cover of the Innova.

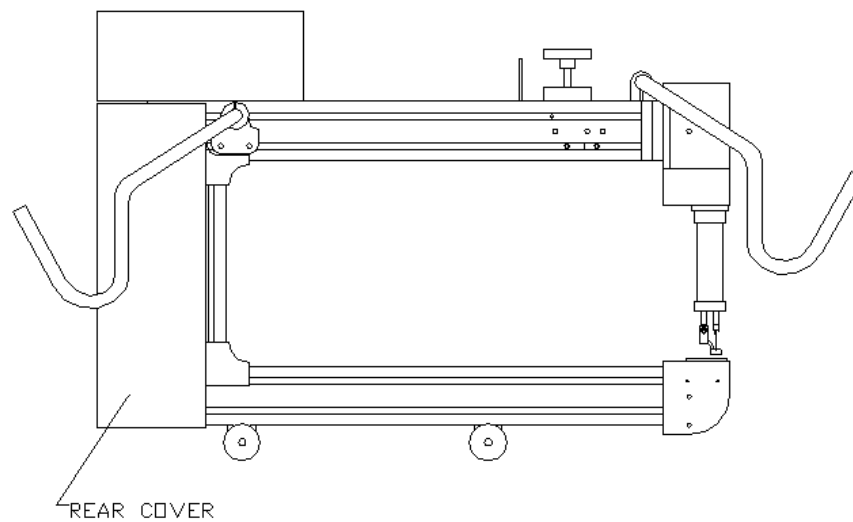

Step 3: Use one of the following illustrations to wire the PantoVision blue box to the Innova.

Proprietary information of ABM INTERNATIONAL, Inc. furnished for customer use only.

No other uses are authorized without the prior written permission of

ABM INTERNATIONAL, INC.

ABM International, Inc.
Model: Innova Longarm Quilting Machine

Series: All Innovas
PantoVision Installation

For Innovas equipped with Lightning Stitch:

Connect the color coded and labeled wires to the corresponding green screw terminal on the Lightning Stitch Board.

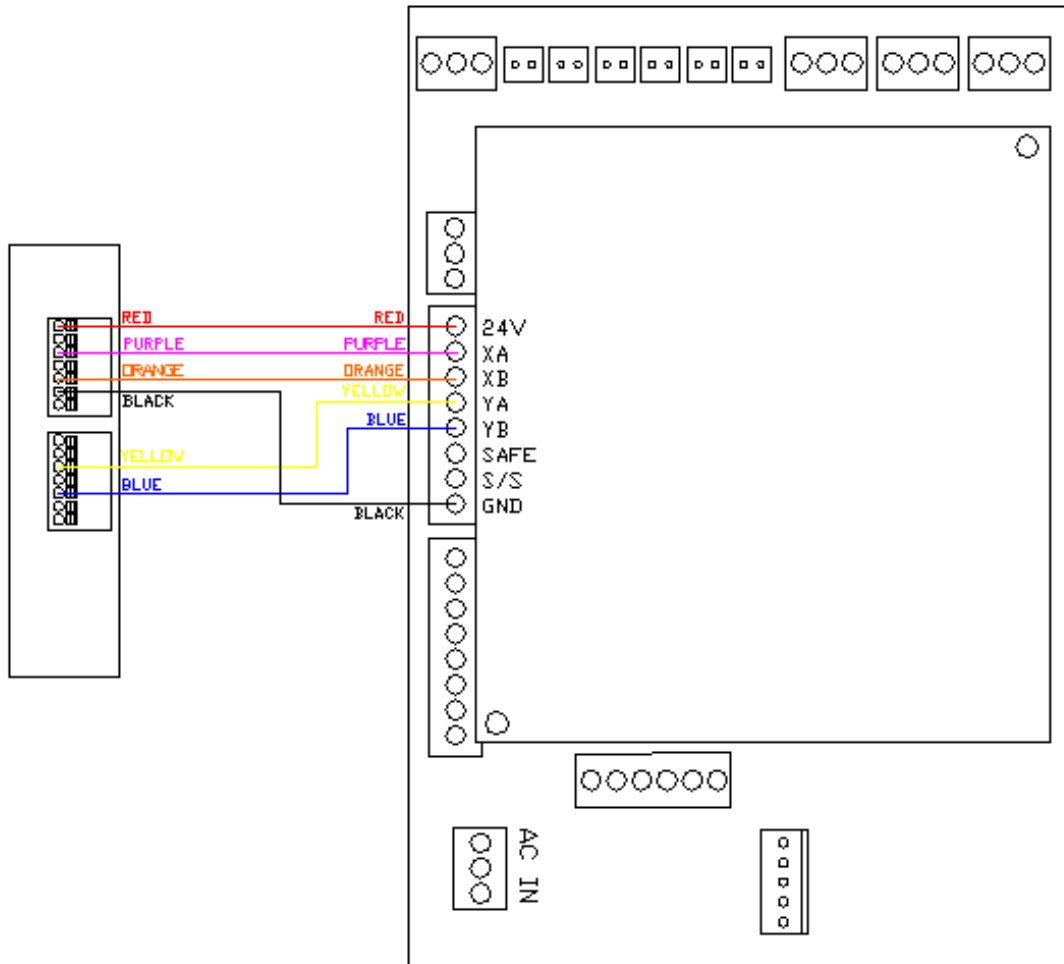

Proprietary information of ABM INTERNATIONAL, Inc. furnished for customer use only.

No other uses are authorized without the prior written permission of

ABM INTERNATIONAL, INC.

ABM International, Inc.
Model: Innova Longarm Quilting Machine

Series: All Innovas
PantoVision Installation

For Innovas equipped with Standard or Pro Stitch Regulation:

SEE DIAGRAM ON FOLLOWING PAGE

- 1) Completely unwire the encoders from the green screw terminal blocks on the back of the PLC. CAUTION, DO NOT REMOVE ANY OTHER WIRES FROM THE PLC.
- 2) Disconnect the X and Y encoder wires (black, blue and brown) from the back of the Innova PLC green screw terminal blocks. Remove the electrical tape and free the tied back white wire from the end of the encoder cable. Tie back the orange and heavy black wire with electrical tape.
- 3) Connect the X and Y axis encoders to the new green terminal block supplied with the PantoVision. Follow the illustration for proper wire locations. NOTE: The X-axis is the encoder that rolls LEFT and RIGHT on the lower carriage of the machine and the Y-axis is the encoder that rolls IN and OUT on the left side of the sewhead.
- 4) Connect the loose RED, BLACK, YELLOW and PURPLE wires to the green screw terminal blocks on the back of the Innova PLC. Make sure that all other wires that are in the terminals do not fall out.

Proprietary information of ABM INTERNATIONAL, Inc. furnished for customer use only.

No other uses are authorized without the prior written permission of

ABM INTERNATIONAL, INC.

ABM International, Inc.
Model: Innova Longarm Quilting Machine

Series: All Innovas
PantoVision Installation

THIS PAGE IS INTENTIONALLY LEFT BLANK

Proprietary information of ABM INTERNATIONAL, Inc. furnished for customer use only.

No other uses are authorized without the prior written permission of

ABM INTERNATIONAL, INC.

ABM International, Inc.
Model: Innova Longarm Quilting Machine

Series: All Innovas
PantoVision Installation

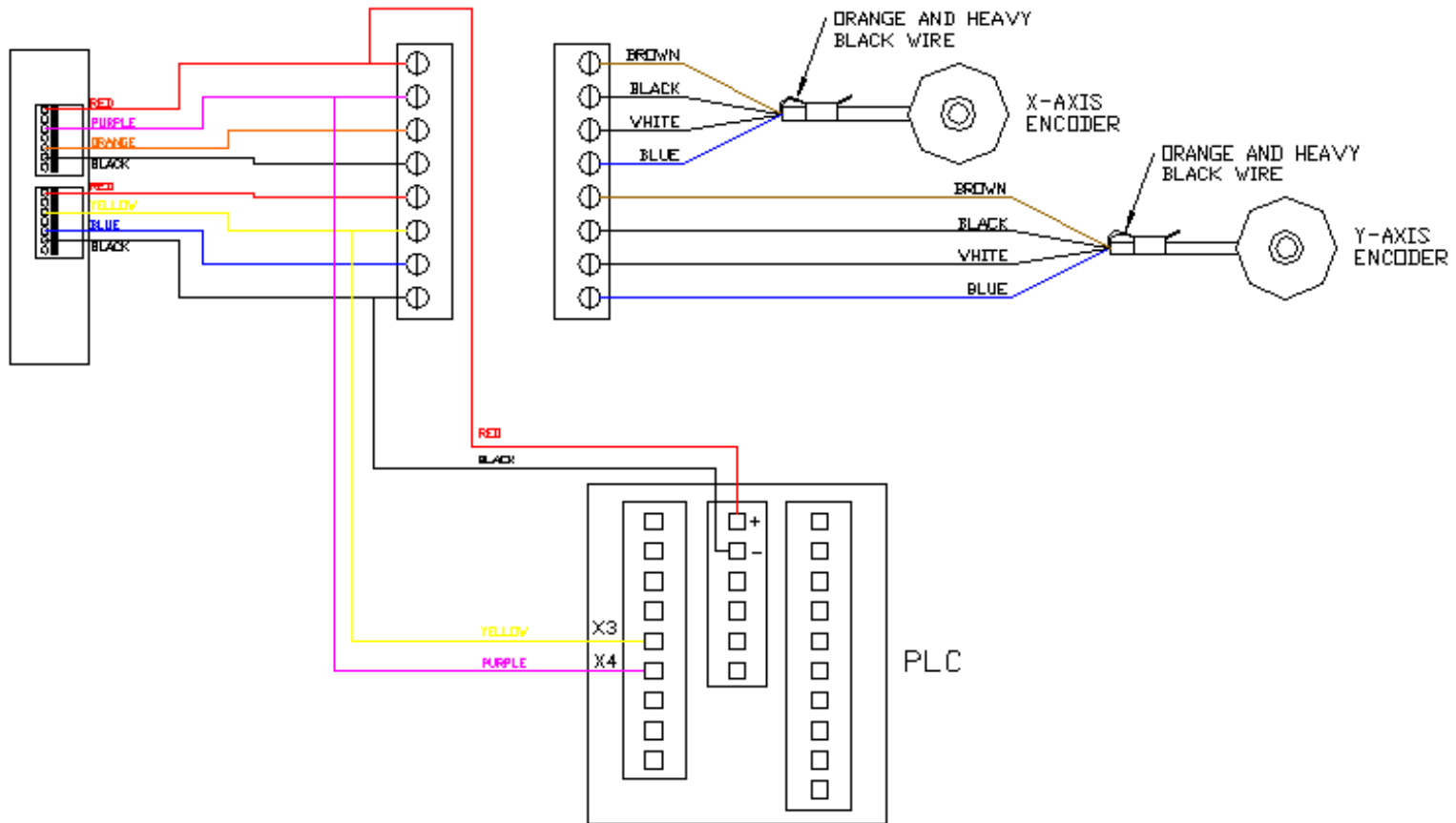

Proprietary information of ABM INTERNATIONAL, Inc. furnished for customer use only.

No other uses are authorized without the prior written permission of

ABM INTERNATIONAL, INC.

ABM International, Inc.
Model: Innova Longarm Quilting Machine

Series: All Innovas
PantoVision Installation

Step 4: Connect the supplied USB cable to the side of the PantoVision blue box.

Step 5: Tuck the blue box into the rear compartment of the Innova and wire tie it in place.

Step 6: Route the USB cable out the bottom of the Innova with the power and encoder cables.

Step 7: Re-install the rear cover.

Step 8: Use the included wire tie mounts to hold the USB cable in the desired location on the side of the Innova.

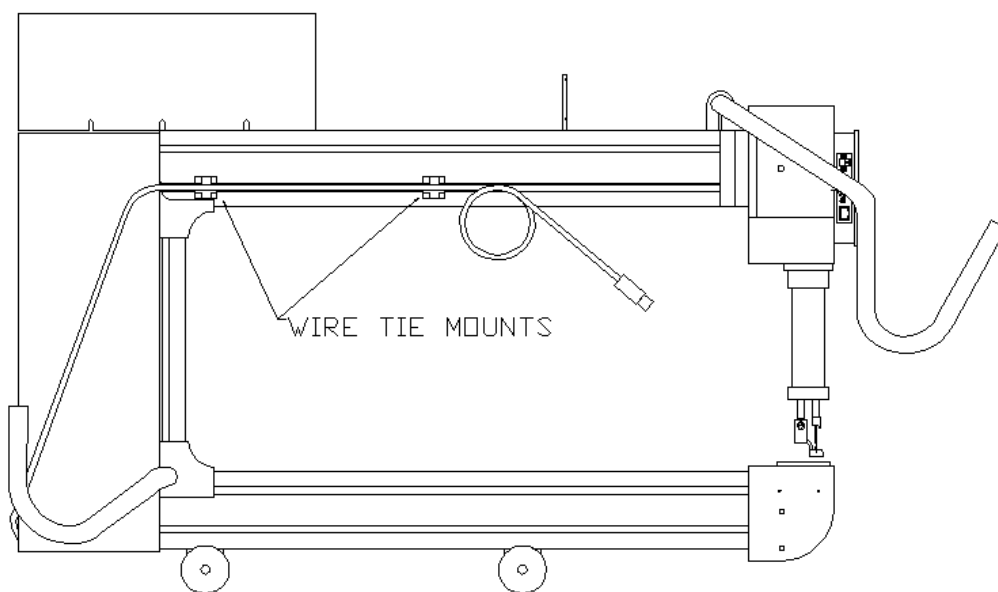

Step 9: Refer to the Software Installation Guide Leaflet provided in the package for software installation.

Proprietary information of ABM INTERNATIONAL, Inc. furnished for customer use only.

No other uses are authorized without the prior written permission of

ABM INTERNATIONAL, INC.